

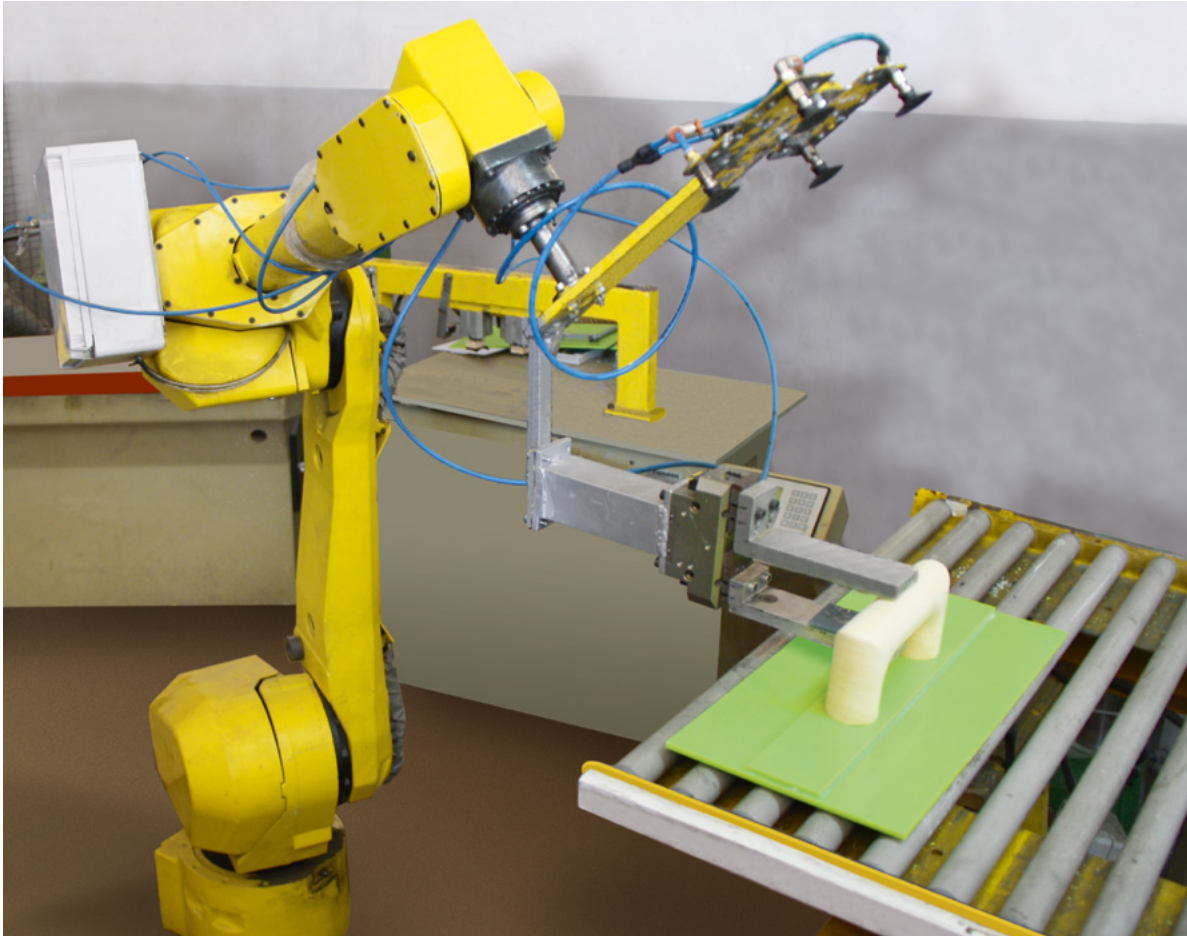

 **vallés**

CATÁLOGO PLAQUISTA

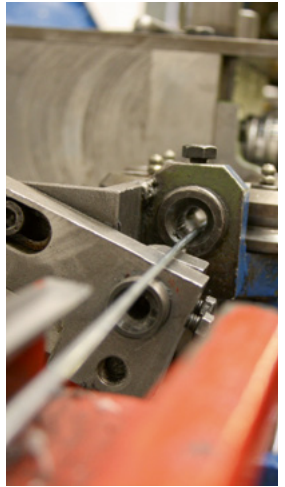

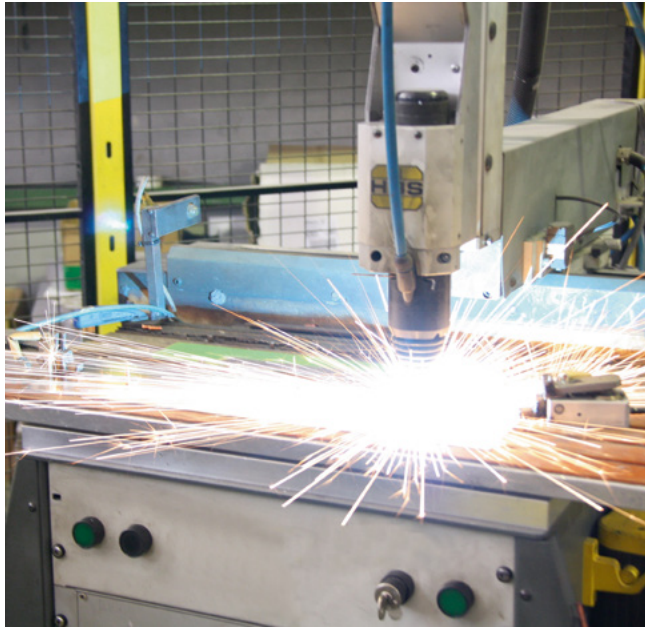

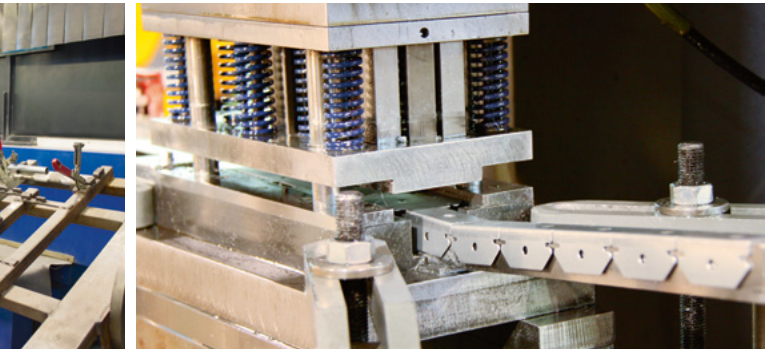
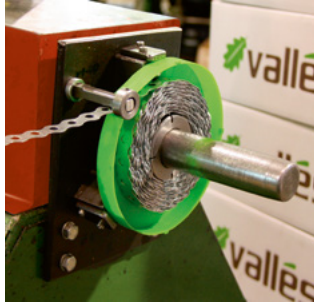
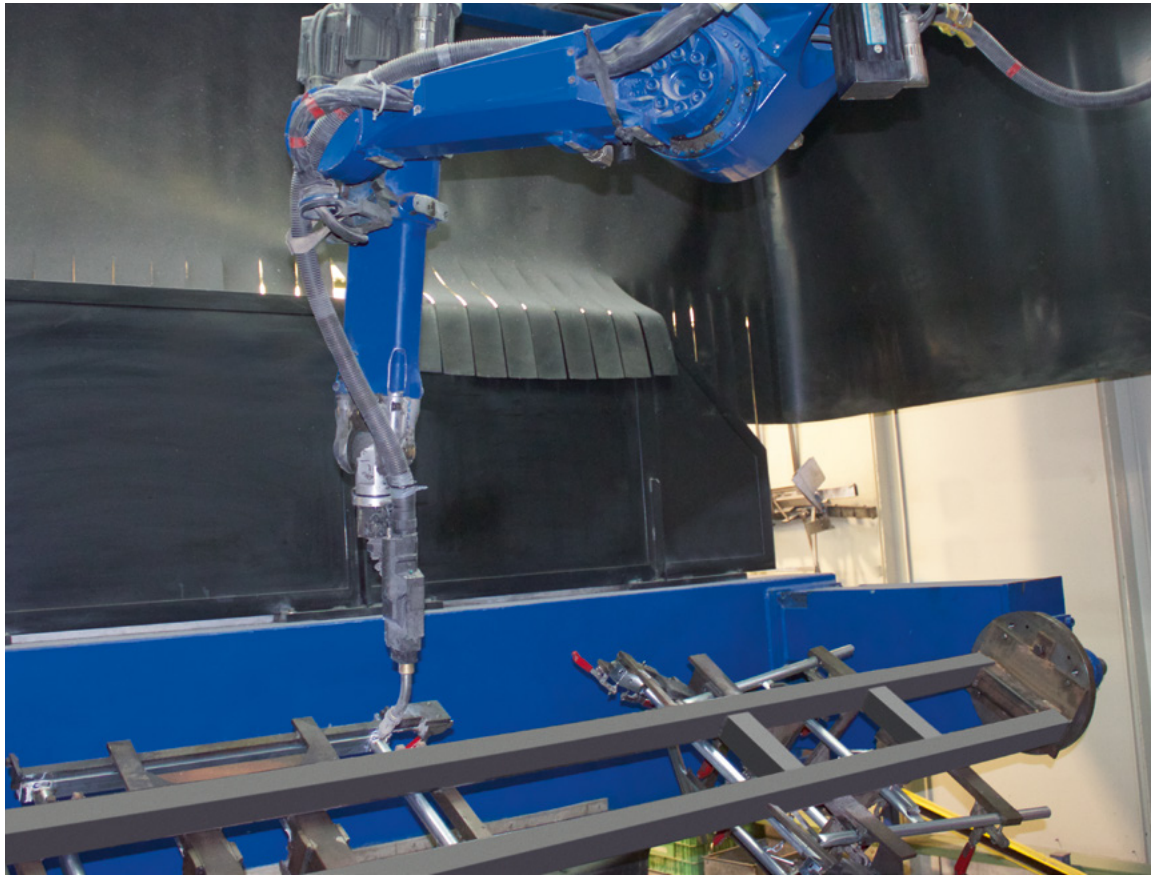

Herramientas de corte 6-7

- 6 serruchos
- 6 cortacírculos
- 6 punzonadora escofina
- 7-8 repuesto cuchilla cepillo-biselador
- 7-8 cortador de placas cartón-yeso
- 8 cepillado biselador
- 00 cortatiras
- 00 repuesto cuchilla cortatiras



Tijeras para chapa 8

- 12 llanas inoxidables dientes
- 12 llanas plástico blanco microcemento
- 12 hoja de plástico blanco



Manipulación de placas 9

- 13 elevador de placas
- 13 carro transportaplacas
- 13 portaplacas
- 13 puntal de placas
- 00 pedal elevaplacas



Cutters 10



Herramientas eléctricas - Accesorios 11

- 16 brocas
- 16 disco de corte
- 16 adaptador para tope de profundidad
- 17 martillo
- 17 amoladora
- 17 atornilladora



Llanas 12



Punzonadora y cizalla 13

- 16 punzonadora
- 16 cizalla cortavarillas



Elevadoras de placas 14



Abrasivos 18



escofina de placas	22
recambio de escofina	22
tacos de lija	22
esponjas de lija	22
lijadora	22
recambio tela abrasiva	22
minilija	22
mango extensible para lijadora de techos	22

Espátulas, paletas y gavetas 20-21



espátulas emplastecer	24
paletas	24
gavetas	24

Zancos ajustables 22



Remachadora 24

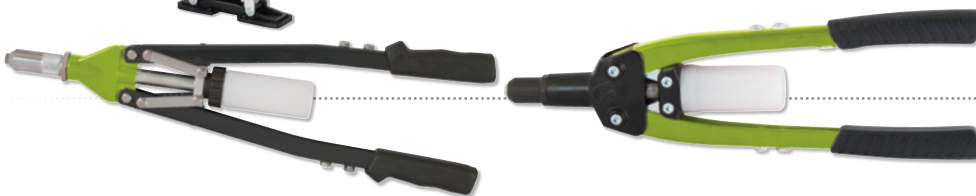

Accesorios plaquista 26

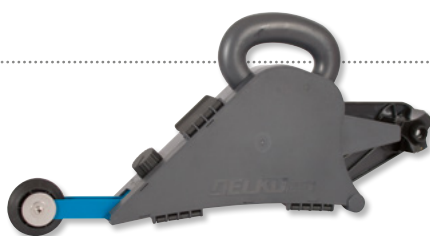

escaleras de madera	24
tiralíneas de plástico	24
polvo para trazar	24
aplicador de cinta	24
tiralíneas	24
cinturones	24

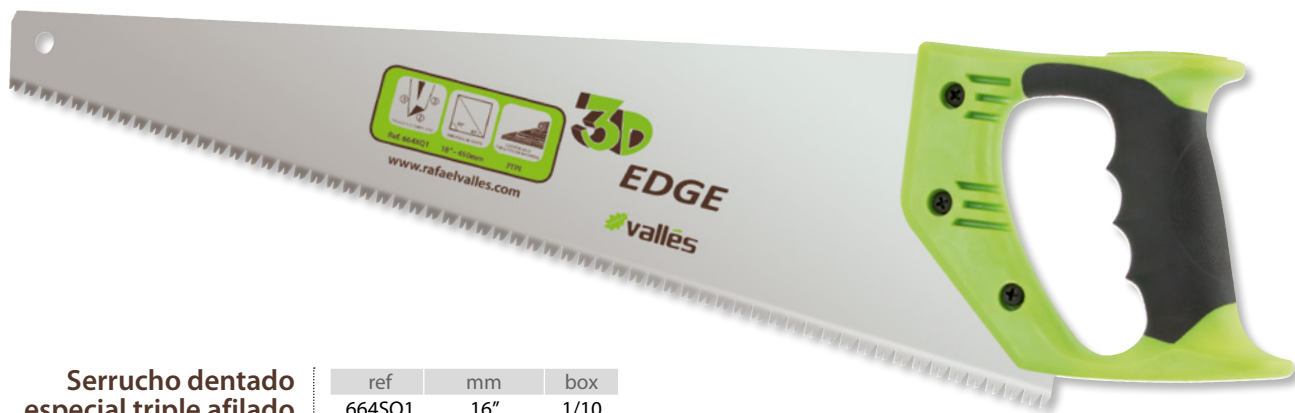

Serrucho dentado especial triple afilado

Triple sharpened tooth saw
Égoïone denté spécial triple fil

ref	mm	box
664SQ1	16"	1/10



Serrucho contornear mango bimatèrial

Bimaterial handle outline saw
Égoïone contourner manche bimatèriel

ref	mm	box
664G06	150	1/24/192



Punzonadora escofina Ø5

Ø5 drilling saw
Ràpe égoïone ø5

ref	mm	box
701002	Ø5x180	1



Cortacírculos

Tiler's drill
Mèche à percer les carreaux

ref	mm	box
664C01	Ø30-80	1

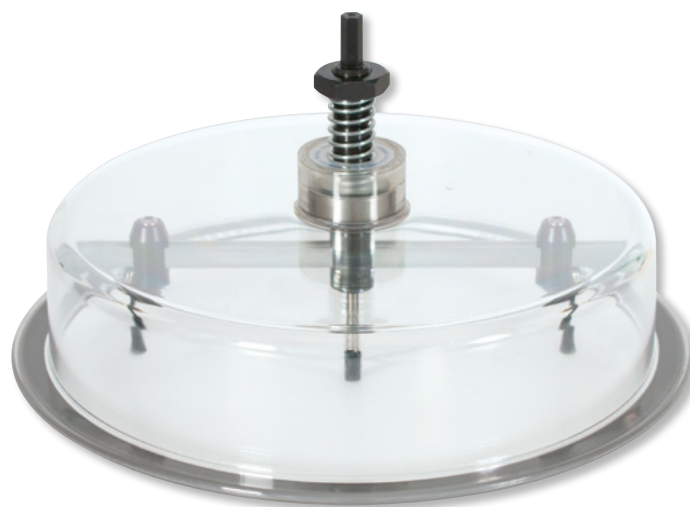

Cortacírculos cerrado

Closed tiler's drill
Mèche à percer les carreaux fermé

ref	mm	box
664C03	Ø52-225	1/bp

Repuesto de cuchillas

Spare blades
Lames de rechange

ref	mm	box
664C03R		2



Cepillo biselador
Special angle plane
Rabot à chanfreiner

ref	mm	box
701006	22'5/45°	1



Repuesto cuchilla cepillo biselador

Special angle plane blade substitute
Remplacement lame rabot à chanfreiner

ref	mm	box
664031	50x30x20	10



Cortador de placas cartón-yeso

Cutter for plaster boards
Coupeuse des plaques à plâtre

ref	mm	box
701603	600	1

VÁLIDO
para las referencias
701003 y 701603



Repuesto cuchilla cortatiras

Short strips blade substitute
Substitut lame court bandes

ref	mm	box
701R03	Ø30	1

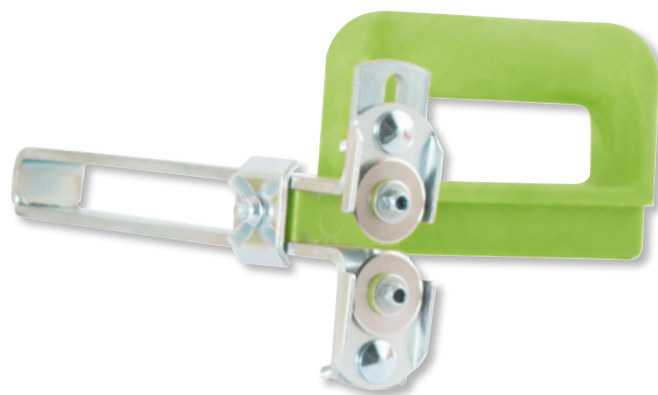

Cortatiras
Short strips
Court bandes

ref	mm	box
701003	200	1

tijeras para chapa

8 plate scissors / ciseaux du plaque



Tijera para chapa apertura rápida

Easy opening plate scissor
Ciseaux du plaque facile ouverture

ref	mm	box
667P05	250x75x25	1/6/48



Tijera para chapa económica

Economic plate scissor
Ciseaux du plaque économique

ref	mm	box
667006	250x75x25	1/10/40



Tijera para chapa Irwin

Irwin plate scissor
Ciseaux du plaque Irwin

ref	mm	box
667PRO	250x75x25	1/5



Carro transportaplacas galvanizado

Galvanized boards transporter
Transporteur de plaques à tiges galvanisé

ref	mm	box
701020	base 80x220	1

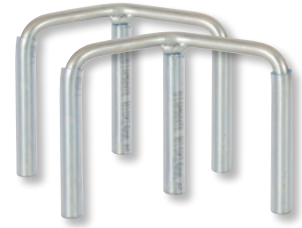

Portaplacas

Carrying handles
Poignée à griffes

ref	mm	box
701001	145x111x50	2



Pedal elevaplacas

Raise plaques pedal
Levier à panneaux

ref	mm	box
701018	820	1



Elevador de placas blocaje

Boards wedge lever
Cale-plaques levier

ref	mm	box
701015	360x135x145	1



Transportador de placas

Boards transporters
Poignée à tiges

ref	mm	box
701031	600	1



Puntal de placas techos inclinados

Ceiling support
Règle pour plaques

ref	mm	box
701021	1150 - 2850	1/6

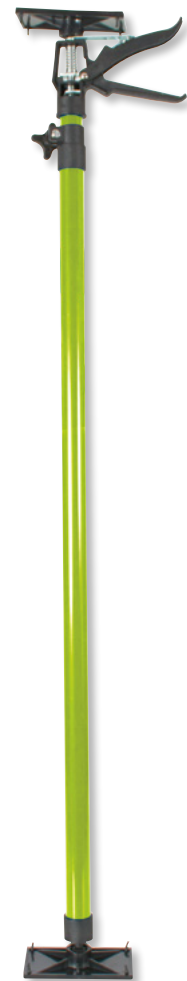

Puntal de placas techos inclinados económico

Economic ceiling support
Règle pour plaques économique

ref	mm	box
701E21	1150 - 2900	1/10/150



Cutter hoja 18 mm.

Cutter blade 18 mm.
Coupeuse lame 18 mm.

ref	mm	box
664040	165	1/12

Cuchilla recambio cutter hoja 18 mm.

Replacement blade cutter blade 18 mm.
Lame replacement coupeuse lame 18 mm.

ref	mm	box
664032	120x20x10	10

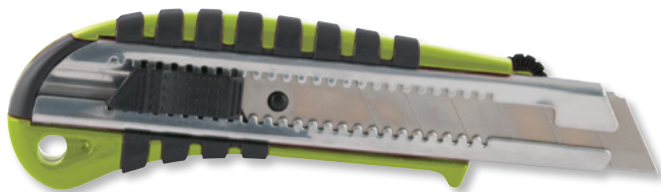

Cutter autoblocante hoja 25 mm.

Self-locking cutter blade 25 mm.
Coupeuse auto-blocus lame 25 mm.

ref	mm	box
664025	25	1/12

Cuchilla recambio cutter hoja 25 mm.

Replacement blade cutter blade 25 mm.
Lame replacement coupeuse lame 25 mm.

ref	mm	box
664033	25	10



Cutter hoja ancha

Wide blade cutter
Coupeuse lame large

ref	mm	box
664030	150x80	1/12

Cuchilla repuesto cutter hoja ancha y cutter navaja

Replacement blade wide blade cutter and penknife cutter
Lame replacement coupeuse lame large et coupeuse canif

ref	mm	box
664031	50x30x20	10

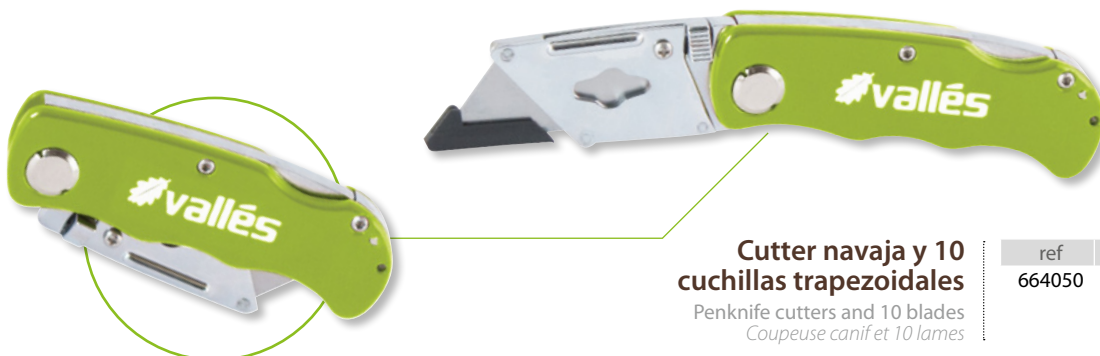

Cutter navaja y 10 cuchillas trapezoidales

Penknife cutters and 10 blades
Coupeuse canif et 10 lames

ref	mm	box
664050	150 - 90	1/12/60



Adaptador roscador de varilla m6 (uds.)

Adapter m6 threaded rod
Adaptateur de filetage m6

ref	mm	box
333XA4	50	1



Adaptador para tope de profundidad

Adapter for top of depth
Adaptateur pour arrêt de profondeur

ref	mm	box
333XA3	65	1/24/192



Brocas SDS plus

SDS plus bits
Mèches SDS plus

ref	mm	box
• 909500	Ø5x50	1/10
• 909600	Ø6x50	1/10
• 909800	Ø8x50	1/10
• 909500E	Ø5x50	1
• 909600E	Ø6x50	1
• 909800E	Ø8x50	1
• 909500L	Ø5x100	1/10
• 909600L	Ø6x100	1/10
• 909800L	Ø8x100	1/10

CARACTERÍSTICAS

- Longitud total: 110 mm.
- Longitud total: 160 mm.



Disco de corte para inoxidables

Court disks for rustproofs
Disque des cour pour inoxydables

ref	mm	box
852DE1	Ø115x1x22	1/25/50



STAYER

herramientas eléctricas

electric tolls / outils électriques



Atornillador Stayer 384 B

Stayer 384 B screwdriver
Tournevis Stayer 384 B

ref	mm	box
703A06	0 - 4500rpm	1

CARACTERÍSTICAS

Autoroscantes: Ø6,3 - m8
Intersección hexagonal: 1/4" - 600 w. - 1'8 kg.



Martillo ligero Stayer HD 27 K

Stayer HD 27 K lightweight hammer
Marteau lumière Stayer HD 27 H

ref	mm	box
703A07	0 - 900rpm	1

CARACTERÍSTICAS

810 w.
Percusiones/min.: 0-4650
Fuerza percusión: 2'8 j.
Inserción: SDS-PLUS - Acero 16 mm.
Piedra: 26 mm.
Corona: 68 mm. - 2'4 kg.



Amoladora angular Stayer SAB 730

Grinder Stayer SAB 730
Meuleuse Stayer SAB 730

ref	mm	box
703A08	0 - 4500rpm	1

CARACTERÍSTICAS

710 w.
Diámetro disco: 115 mm. - m14 - 1'7 kg.



Llana curva

Curve trowel
Truelle courbe

ref	mm	box
663CV1	300x120	1/6/48



Llana inoxidable mango americano

American handle rustproof trowel
Truelle inoxydable manche américain

ref	mm	box
663IAC	280x130	1/12



Llana inoxidable mango americano goma

Rubber american handle rustproofs trowels
Truelles inoxydables manche américain gomme

ref	mm	box
663IAL	240x100	1
663IAZ	200x80	1



Llana inoxidable mango americano goma c. redondos

American handle rustproof trowel rounded edges
Truelle inox. manche américain caoutchouc chansons rondes

ref	mm	box
66IAZR	200x80	1



Llana inoxidable mango americano goma especial

Special rubber american handle rustproof trowel
Truelle inoxydable manche américain gomme spécial

ref	mm	box
663IAGE	280x130	1/12



Llana inoxidable afilada mango americano goma especial

Special rubber american handle sharpened rustproof trowel
Truelle inoxydable effilée manche américain gomme spécial

ref	mm	box
663IAGE2	280x130	1/12/bp





Punzonadora de perfiles para 1 mano

Profiles tong for 1 hand
Pince a sentir les profilés 1 main

ref	mm	box
701011	1,2	1/6/24



Punzonadora de perfiles para 2 manos

2 hands profiles tong
Pince a sentir les profilés 2 mains

ref	mm	box
701014	1,8	1/9



Punzonadora de perfiles 2 manos esquinas

2 hands corners profiles tong
Pince a sentir les profilés pour 2 mains coins

ref	mm	box
701E14	1,8	1/bp



Punzonadora de perfiles 2 manos económica

Economic 2 hands profiles tong
Pince a sentir les profilés 2 mains économique

ref	mm	box
701014E	1,8	1/6/24



Punzonadora de perfiles Ø25 mm. para cables

Ø25 mm. profiles tong for cord
Pince a sentir les profilés Ø25 mm. pour câbles

ref	mm	box
701032	Ø25	1



Cizalla cortavarillas

Metal shears cutrod
Cisaille grignoteuse coupetige

ref	M	box
704C01	corte M4/M6/M8	1/20



Elevador placas 3,5 m. y tableros

*3,5 m. plates elevator and boards
Ascenseur du plaques 3,5 m. et planches*

ref	mm	box
701027		1

CARACTERÍSTICAS

- Altura máxima: 3,5 m., con alargador: 4 m.
- Plataformas para facilitar el posicionamiento de la placa
- Carga máxima: 50 kg.
- Peso total: 46 kg.
- Mínimo horizontal de la placa: 1,4 m.



701A27 Alargador

*Extension
Agrandissement*

Elemento opcional, no incluido con la ref. 701027

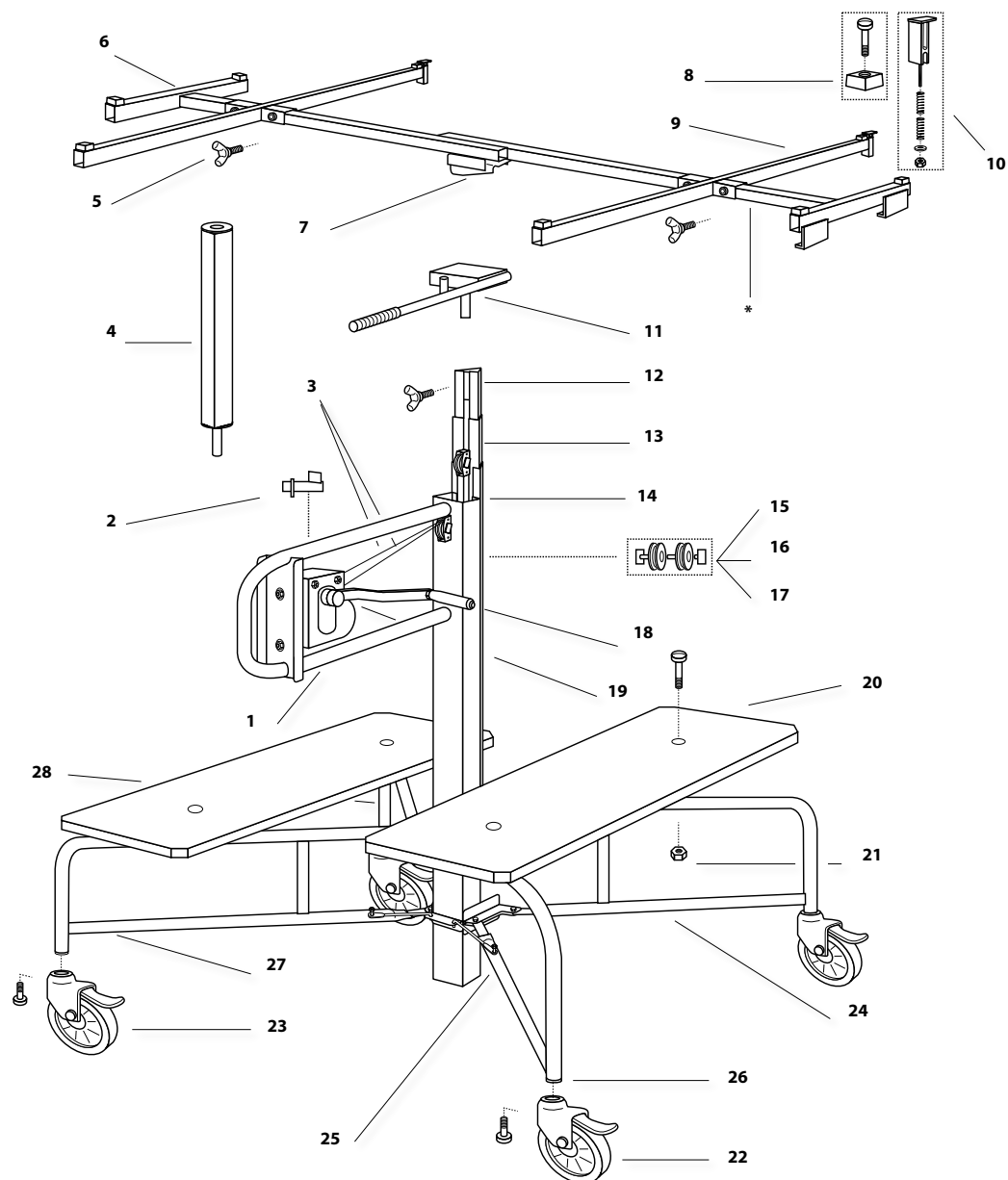

701027

Elevador placas 3,5 m. y tableros

3,5 m. plates elevator and boards

Ascenseur du plaques 3,5 m. et planches

núm.	descripción	piezas
1	caja	1
2	abrazadera de seguridad	1
3	cuerda de metal	1
4	extensión ajustable	1
5	brazo izquierdo abatible	2
6	posición central	1
7	línea de carga	1
8	kit soporte goma	6
9-10	brazo derecho abatible	2
	kit soporte de plástico	2
11	manivela de control	1
12	poste de unión	1
13	poste de levantamiento	1
14	columna central	1

núm.	descripción	piezas
15	clavija	1
16	polea	2
17	muelle arandela	1
18	set manivela	1
19	set engranaje	1
20	tablero	2
21	tornillo con tuerca mariposa	4
22	rueda con frenos	2
23	rueda sin frenos	2
24	pierna 1	1
25	posicionador pierna	2
26	pierna 2	1
27	pierna 3	1
28	pierna 4	1



**Elevador de placas II 3,5 m.
3 patas**

3 legs 3,5 m. plates elevator II
Ascenseur du plaques II 3,5 m. 3 jambes

ref	mm	box
701030	1360x900x250	1

CARACTERÍSTICAS

- Altura máxima: 3,5 m., con alargador: 4 m.
- Diámetro de la base: 1,2 (alta estabilidad).
- Carga máxima: 50 kg.
- Peso total: 36 kg.
- Mínimo horizontal de la placa: 1,45 m.



701A27
Alargador
Extension
Agrandissement

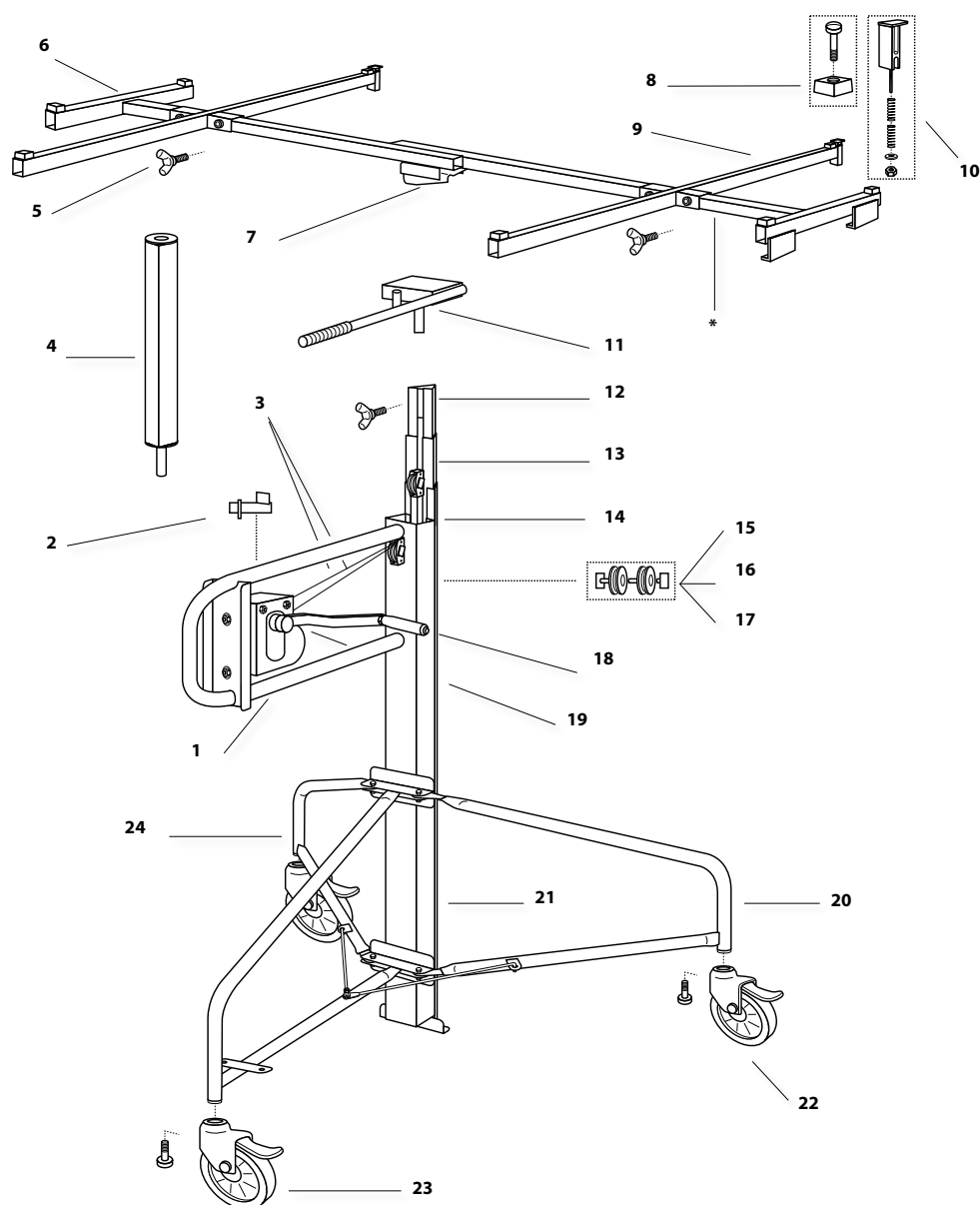

701030

Elevador de placas II 3,5 m. 3 patas3 legs 3,5 m. plates elevator II
Ascenseur du plaques II 3,5 m. 3 jambes

núm.	descripción	piezas
1	caja	1
2	abrazadera de seguridad	1
3	cuerda de metal	2
4	extensión ajustable	1
5	brazo izquierdo abatible	2
6	posición central	1
7	línea de carga	1
8	kit soporte goma	6
9-10	brazo derecho abatible	2
	kit soporte de plástico	2
11	manivela de control	1
12	poste de unión	1

núm.	descripción	piezas
13	poste de levantamiento	1
14	columna central	1
15	clavija	1
16	polea	2
17	muelle arandela	1
18	set manivela	1
19	set engranaje	1
20	soporte pierna	1
21	posicionamiento pierna	2
22	rueda con frenos	2
23	rueda sin frenos	1
24	soporte pierna	1



Escofina de placas pequeña

Small rasp
Rabot pour plaques petite

ref	mm	box
701016	63	1/12



Recambio escofina de placas pequeño

Small refill rasp
Rabot métallique pour plaques rechange petite

ref	mm	box
701017	63	1/12



Escofina de placas tipo escarabajo

Beetle rate rasp
Rabot métallique pour plaques type coléoptère

ref	mm	box
701022	140	1/12/96

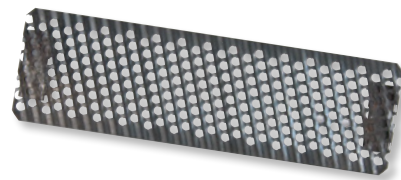

Recambio escofina de placas mediano

Medium refill rasp
Rabot métallique pour plaques rechange médiane

ref	mm	box
701023	140	1/12



Escofina de placas

Rasp
Rabot métallique pour plaques

ref	mm	box
701004	250	1/12/48

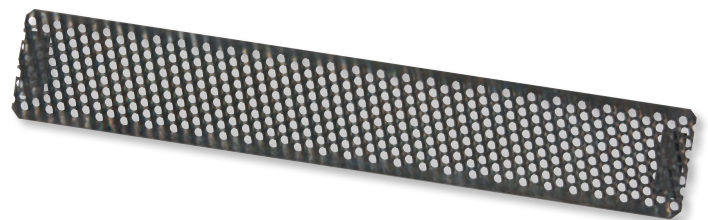

Recambio escofina de placas grandes

Big refill rasp
Rabot métallique pour plaques rechange grand

ref	mm	box
701005	250	1/12

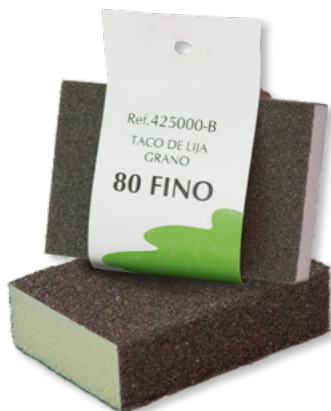

Tacos de lija

Plain cues
Morceaus verré

ref	mm	box
425000	grano fino	1/50/100
425001	grano grueso	1/50/100
• 425000-B	grano fino	1/20
• 425001-B	grano grueso	1/20

• Con blíster

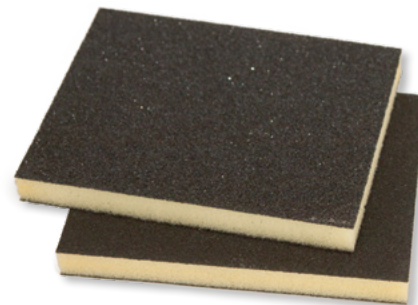

Esponjas de lija flexibles

Sponges of flexible plain
Éponges de verre flexible

ref	mm	box
425002	grano fino	1/50/100
425003	grano grueso	1/50/100



Lijadora de mano

Hand-grinder
Raseur à main

ref	mm	box
701008	240x90	1/12



Minilija superprofesional y 10 lijas

Superprofessional grinder and 10 sandpaper
Raseur professionnel et 10 papier de verre

ref	mm	box
7010ML	88x190	1/12/48

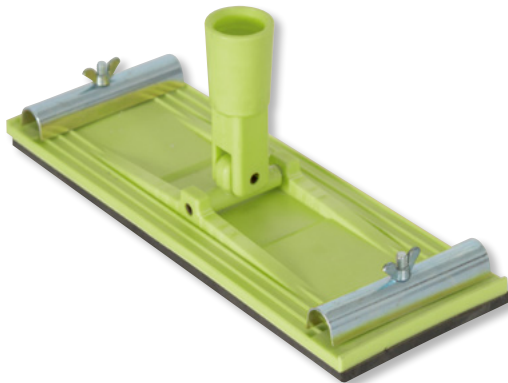

Lijadora para techos

Roofs grinder
Raseur pour plafonds

ref	mm	box
701010	240x90	1/10/60



Mango extensible para lijadora de techos

Roofs grinder extensible handle
Extensible manche de raseur pour plafonds

ref	mm	box
663M22	1820x910	1

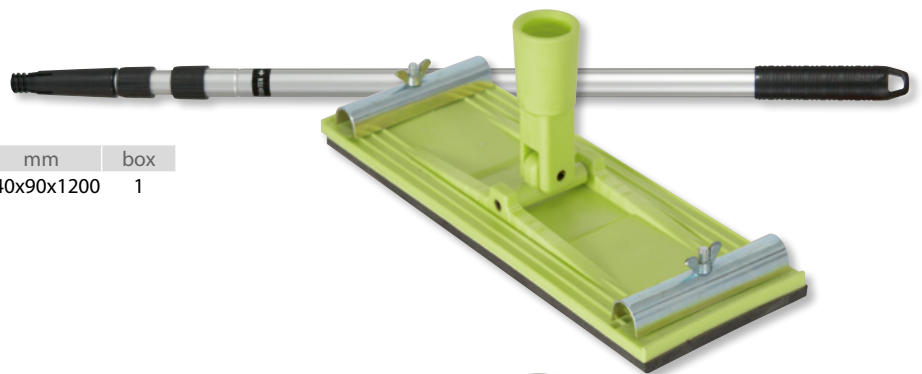

Lijadora para techos y mango 1,2 m.

Roofs grinder and handle 1,2 m.
Raseur pour plafonds et manche 1,2 m.

ref	mm	box
701024	240x90x1200	1

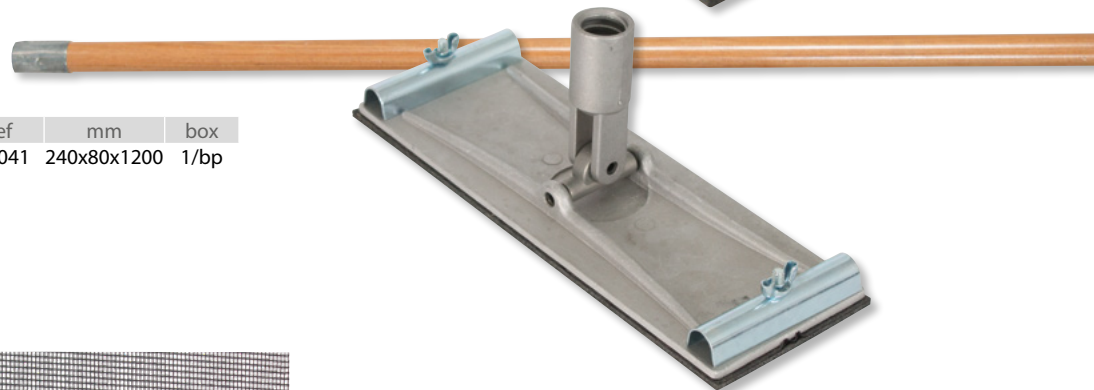

Lijadora para techos aluminio y mango de madera 1,2 m.

Aluminum roofs grinder and wood handle 1,2 m.
Raseur pour plafonds d'aluminium et manche bois 1,2 m.

ref	mm	box
701041	240x80x1200	1/bp

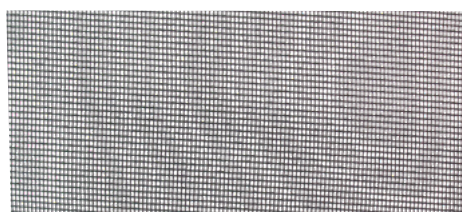

Recambio tela abrasiva para lijadoras

Abrasive for grinders
Abratif pour raseurs

ref	mm	box
701009	280x115	10/60

Espátulas emplastecer inox. flex. m. bimaterial

Bimaterial handle flex. rustproofs
smoothers for putting
*Couteaus a enduire flex. inox. avec
manche bimaterial*

ref	mm	box
904G11	150	1/12/72
904G12	200	1/12/72
904G13	250	1/12/72



Paletas inoxidables flexibles mango goma

Rubber handle flexibles
rustproofs palettes
*Spatules inoxydables flexibles
manche gomme*

ref	mm	box
904S50	50	1/12/192
904S75	75	1/12/192
904S10	100	1/12/144
904S15	150	1/12/144
904S12	125	1/12/144



Paleta inoxidable con destornillador m. goma

Rubber handle rustproof palette
with screwdriver
*Spatules inoxydables avec tournevis
manche gomme*

ref	mm	box
904G15	150	1/12/144



gavetas

joint compound mud pan / tiroirs



Gaveta de plástico

Plastic joint compound mud pan
Tiroir du plastique

ref	mm	box
670P00	300	1/10/60



Paletas inox. mango ergo. bimaterial

Bimaterial ergo. handle
rustproofs palettes
Spatules inox. manche ergo. bimatériel

ref	mm	box
904RG1	100	1/6/48
904RG2	120	1/6/48
904RG3	140	1/6/48
904RG4	160	1/6/48
904RG5	180	1/6/48
904RG6	200	1/6/48
904RG7	220	1/6/48
904RG8	240	1/6/48



Paletas inoxidable redondas

Ronds rustproofs palettes
Spatules inoxydables rondes

ref	mm	box
904J12	120	1
904J15	150	1
904J17	170	1



Paleta inox. destorn. 5 puntas m. goma econ.

Econ. rubber handle 5 spikes
screwdriver rustproof palette
Spatule inox. tournevis 5 pointes
manche gomme économique

ref	mm	box
904G15E	150	1/6/144



Gaveta galvanizada

Galvanized compound mud pan
Tiroir galvanisé

ref	mm	box
670G00	300	1/6/60

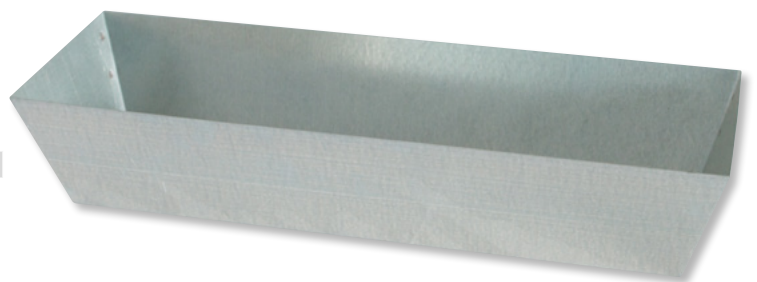



Zancos ajustables "Pro-Evolution"®

"Pro-Evolution"® adjustable stilts
Échasses adaptables "Pro-Evolution"®

ref	mm	box
3P1003	60 - 101	1

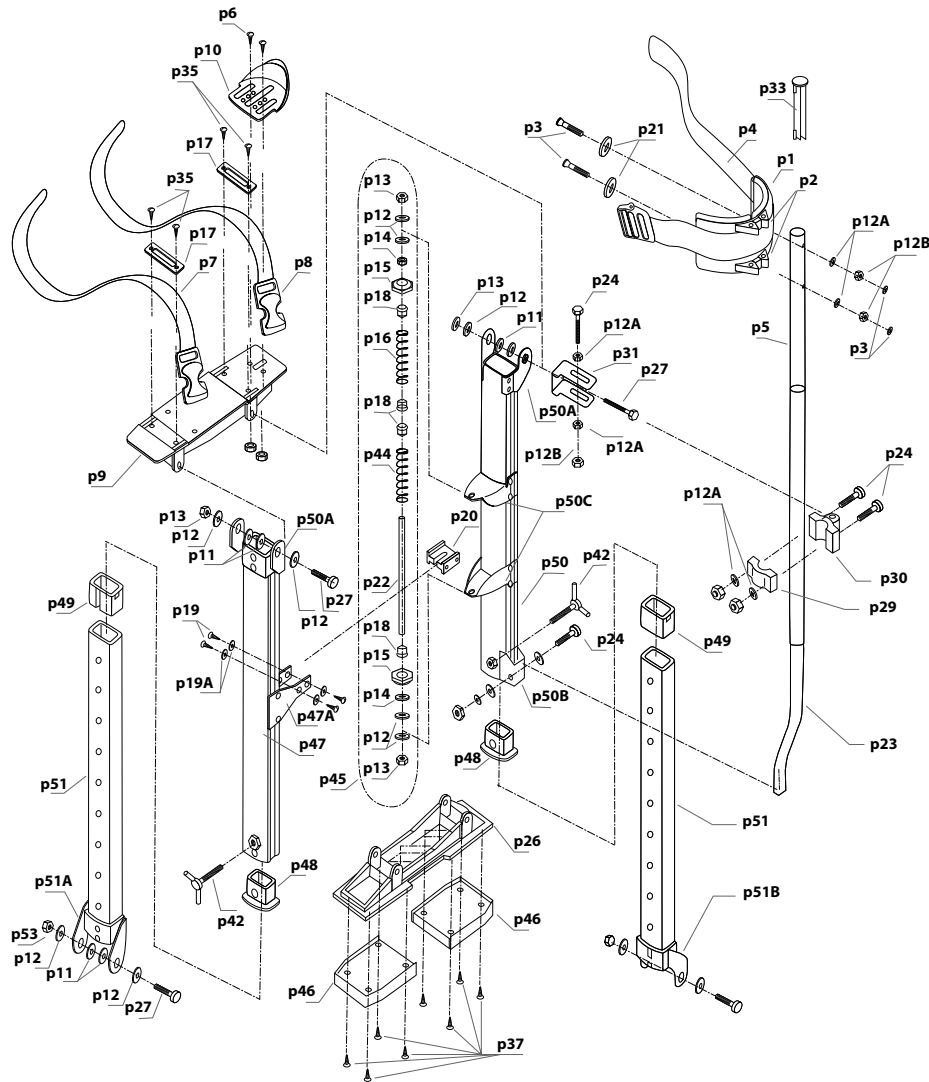

3P1003

Zancos ajustables "Pro-Evolution"® "Pro-Evolution"® adjustable stilts · Échasses adaptables "Pro-Evolution"®

ref.	n.º	descripción
3P1R01	p1	Banda con almohadilla para la pierna
3P1R02	p2	Espaciador de las bandas de las piernas
3P1R03	p3	Tornillo de cabeza plana + tuerca freno
3P1R04	p4	Correa para la pierna
3P1R0524	p5	24, montante lateral superior diám. Ext. 1 - 1/8"
3P1R06	p6	Tornillo m5x12 din965 + tuerca autoblocante m5
3P1R07	p7	Correa trasera de pie
3P1R08	p8	Correa delantera de pie
3P1R09	p9	Placa de nylon para el pie
3P1R10	p10	Soporte ajustable del talón
3P1R11	p11	Rodamiento de nylon
3P1R12	p12	Arandela m6
3P1R12A	p12	Tipo "a" arandela m6 - SAE
3P1R12B	p12	Tipo "b" arandela cuadrada
3P1R13	p13	Tuerca autoblocante 1/4"
3P1R14	p14	Tuerca hexagonal 1/4" - 20"
3P1R15	p15	Ajustado del resorte
3P1R16	p16	Muelle superior negro
3P1R17	p17	Placa metálica para montar la correa
3P1R18	p18	Cojinete de nylon de resorte
3P1R19	p19	Tornillo autoenroscante número 8x3/8"
3P1R19	p19	Tipo "a" arandela para nº 19
3P1R19	p19	Tipo "b" arandela partida para el nº 19
3P1R20	p20	Divisor del resorte
3P1R21	p21	Arandela grande para el soporte de la banda de la pierna
3P1R22	p22	Pasador 1/4"x7 - 7/8" ambos extremos roscados
3P1R2315	p23	15, tubo montante inferior Inter-Lok. diám. Ext. 1" (1523)

ref.	n.º	descripción
3P1R2324	p23	24, tubo montante inferior Inter-Lok. diám. Ext. 1" (2440)
3P1R24	p24	Perno de sombrerete 1/4" - 20x1 - 5/8"
3P1R26	p26	Placa de nylon para el piso
3P1R27	p27	Perno de sombrerete 1/4"-20x1-5/8" c7 contratuerca
	p28	Perno de sombrerete 1/4"-20x1-5/8" c7 contratuerca
3P1R29	p29	Abrazadera de remate de montante lateral (F)
3P1R30	p30	Abrazadera de apoyo de montante lateral (B)
3P1R31	p31	Soporte metálico de sujeción de 3 mm.
	p32	Perno de sombrerete 1/4" - 20x1 - 5/8"
	p33	Tapón para el tubo del montante superior
3P1R35	p35	Tornillo para montar la correa
3P1R37	p37	Tornillo para montar la planta
3P1R42	p42	Tornillo de ajuste de altura
3P1R44	p44	Muelle inferior galvanizado
	p45	Conjunto completo resorte
3P1R46	p46	Planta reemplazable
3P1R4715	p47	15, extrusión delantera ajustable de la pierna
3P1R4718	p47	18, extrusión delantera ajustable de la pierna
3P1R4724	p47	24, extrusión delantera ajustable de la pierna
3P1R47A	p47	Tipo "a" abrazadera central de los muelles
3P1R48	p48	Casquillo grande nylon
3P1R49	p49	Casquillo pequeño nylon
3P1R50A	p50	Tipo "a" abrazadera superior extrusión delantera
3P1R50B	p50	Tipo "b" abrazadera intermedia extrusión
3P1R50C	p50	Tipo "c" abrazadera superior e inferior extrusión delantera
3P1R5124	p51	24, extrusión interior



**Remachadora
Schnellfix Riveter**

Schnellfix Riveter riveting machine
Machine pour riveter Schnellfix Riveter

ref	mm	box
914M04		1/12

despiece

exploded / explosée

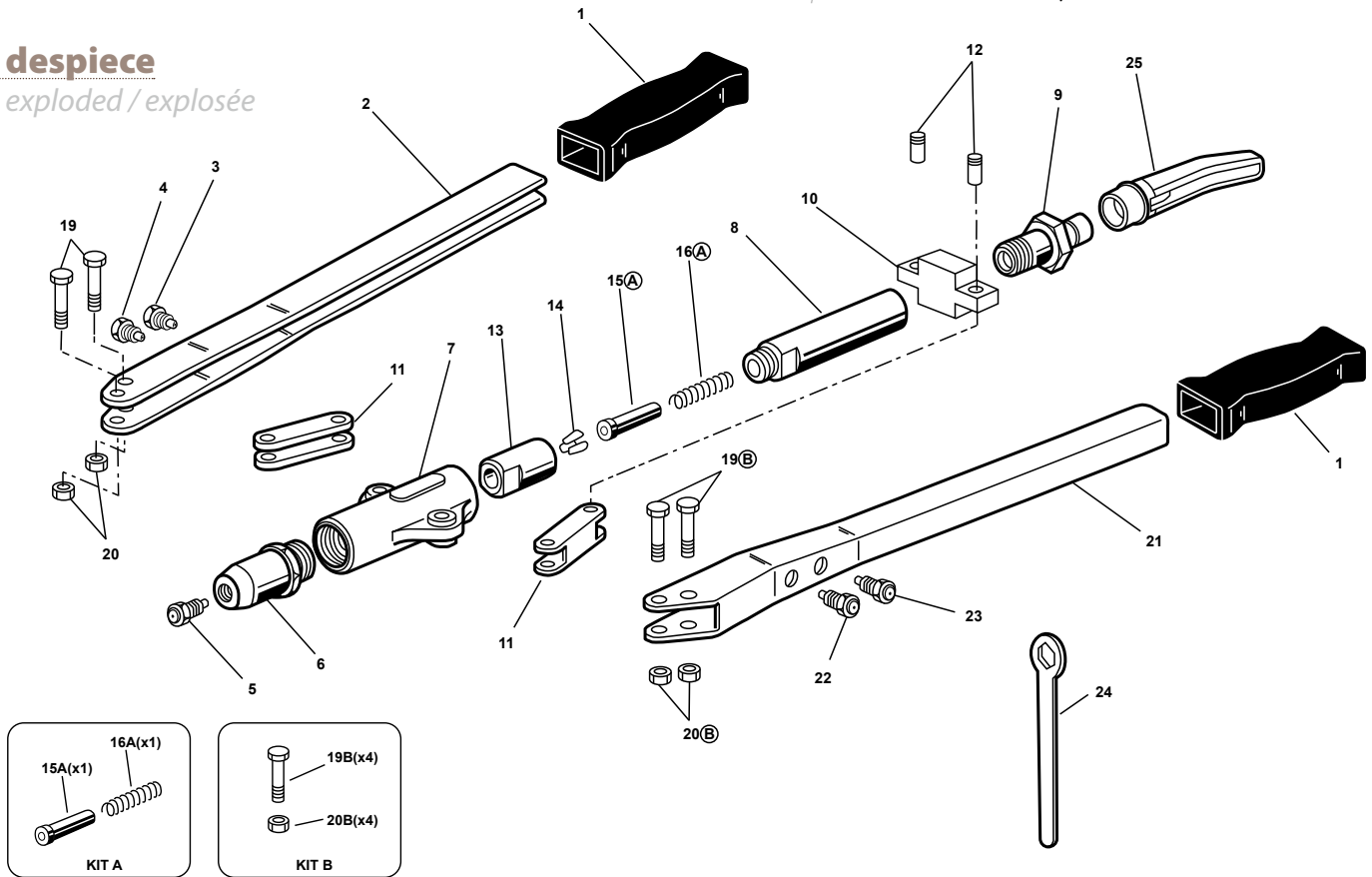

ref.	n.º	descripción
914M0401	1	Cuerpo externo remachadora
914M0402	2	Cabeza desahogo boquilla
914M0403	3	Cono portamordazas
914M0404	4	Mordaza
914M0405	5	Boquilla 3,2 mm.
914M0405B	5	Boquilla 4 mm.
914M0405C	5	Boquilla 4,8 mm.
914M0405D	5	Boquilla 6 mm.
914M0405E	5	Boquilla 6,4 mm.
914M0406	6	Aprietamordaza
914M0407	7	Muelle aprieta mordaza
914M0408	8	Tuerca aprieta mordaza
914M0409	9	Portacono
914M0410	10	Tornillo corto

ref.	n.º	descripción
914M0411	11	Tornillo largo
914M0412	12	Pletina biela
914M0413	13	Pieza base eje
914M0414	14	Tuerca portacono
914M0415	15	Tapón rosca
914M0416	16	Recipiente residuos
914M0417	17	Palanca
914M0418	18	Empuñadura
914M0419	19	Biela
914M04B01	b01	Tuerca m5 autoblocante
914M04B02	b02	Arandela Ø5x0,8
914M04B03	b03	Arandela Ø6x0,8
914M04B04	b04	Arandela Ø6x0,6



Remachadora K20/95

K20/95 riveting machine
Machine pour riveter K20/95

ref	mm	box
914M03	450	1

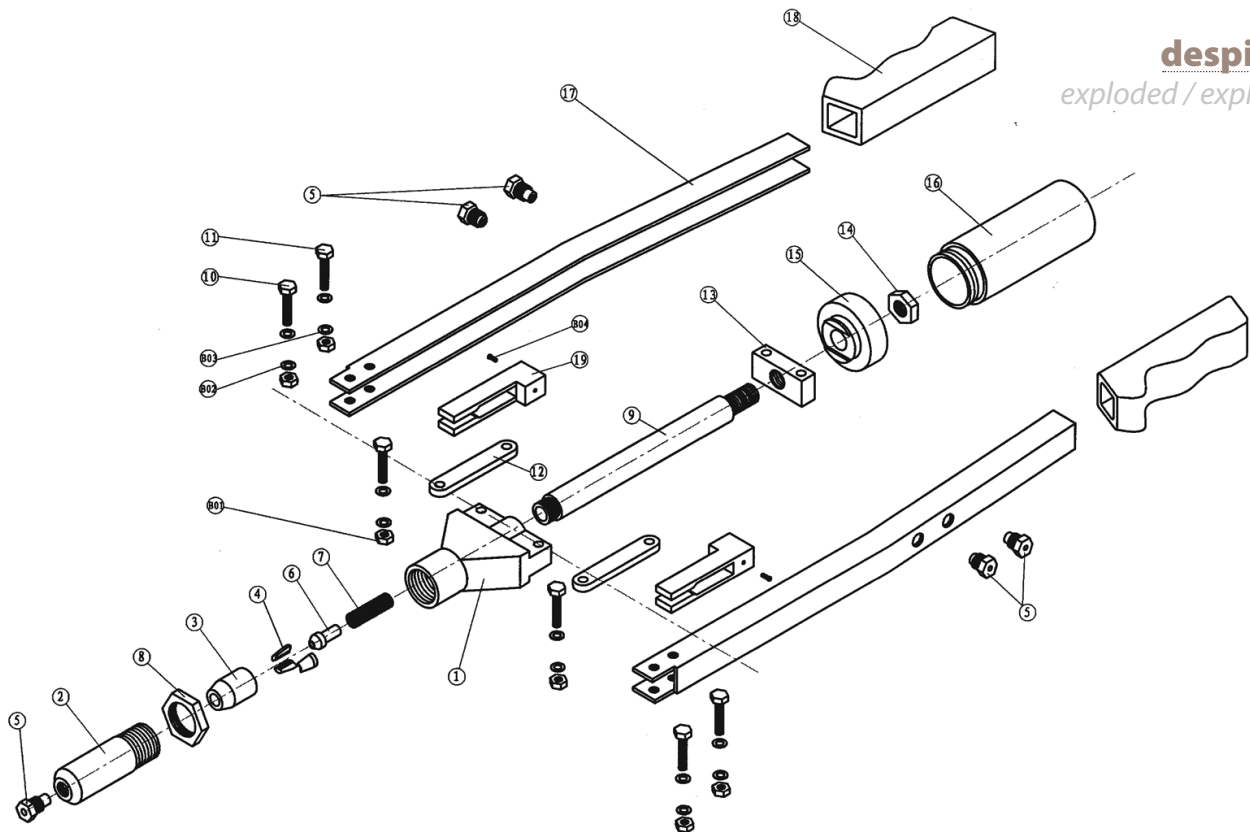

despiece
exploded / explosée

ref.	n.º	descripción
914M0301	1	Empuñadura
914M0302	2	Palanca derecha
914M0303	3	Repuesto boquilla Ø2,4/3,4
914M0304	4	Repuesto boquilla Ø4
914M0305	5	Boquilla Ø4,8
914M0306	6	Cabeza desahogo boquilla
914M0307	7	Cuerpo externo
914M0308	8	Porta cono
914M0309	9	Tornillo m15x1,5
914M0310	10	Biela apoyo
914M0311	11	Biela
914M0312	12	Perno

ref.	n.º	descripción
914M0313	13	Empuñadura
914M0314	14	Mordaza
914M0315A	15	Repuesto boquilla Ø2,4/3,4
914M0316A	16	Repuesto boquilla Ø4
914M0319B	17	Boquilla Ø4,8
914M0320B	18	Cabeza desahogo boquilla
914M0319	19	Cuerpo externo
914M0321	21	Porta cono
914M0322	22	Tornillo m15x1,5
914M0323	23	Biela apoyo
914M0324	24	Biela



Recambio taco

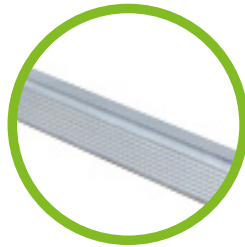

Peldaño antideslizante de 3 cm

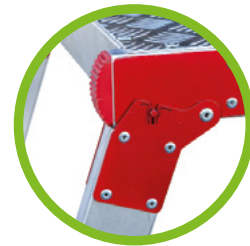

Bisagra de seguridad



701052

Plataforma de trabajo plegable para uso profesional

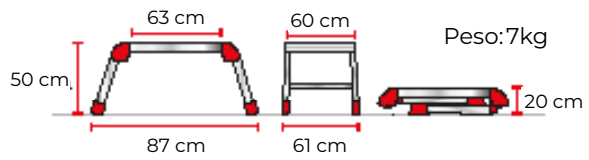

Plataforma plegable

xxxxe
xxx

ref	mm	box
701052		BP

Escaleras madera peldaños planos y conteras

Flat rungs stairs and tips
Escallers marche plats et pointes

ref	mm	altura	box
125MC3	3 peldaños	75 cm	1
125MC4	4 peldaños	100 cm	1
125MC5	5 peldaños	125 cm	1
125MC6	6 peldaños	150 cm	1
125MC7	7 peldaños	175 cm	1
125MC8	8 peldaños	200 cm	1
125MC9	9 peldaños	225 cm	1
125MCA	10 peldaños	250 cm	1

Repuesto contera

Tips recharge
Remplacement pointes

ref	mm	box
125MC0		4



Cinturones profesionales de piel

Leather professionals belts
Ceintures professionnelles du cuir

ref	mm	box
846001	estandar	1/25/300



Tiralíneas plomado de plástico 20 m.

20 m. plastic tracers
Traceurs de plastique 20 m.

ref	mm	box
810PJ0	150x75x30	1/25



Polvo para trazar

Powder to draw
Poussière pour dessiner

ref	grs	box
810A03	250	1/10/60
810A02	1000	1/12



Tiralíneas bimaterial 30 m.

30 m. bimaterial tracers
Traceurs bimatérial 30 m.

ref	mtrs	box
810PJ1	30	1/12

Incluye 115 gr. de polvo trazador.

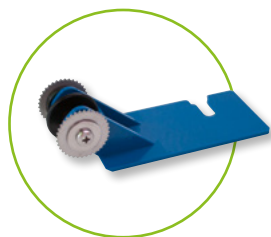

Aplicador de cinta y pasta doble empuñadura

Double handle tape and paste applicator
Applicateur de ruban et pâte avec double manche

ref	mm	box
703C03	21x3x27	1/5



CONDICIONES DE VENTA

Rafael Vallés Arándiga, S.L.

Cuestiones generales

- Las presentes condiciones regirán para todas las ventas realizadas por Rafael Vallés Arándiga, S.L. El cliente se somete a ellas por el mero hecho de confirmar, cumplimentar y recibir los pedidos efectuados a Rafael Vallés Arándiga, S.L.
- El suministro se entenderá efectuado en los locales propiedad de Rafael Vallés Arándiga, S.L., viajando la mercancía por riesgo del cliente.
- Rafael Vallés Arándiga, S.L. se reserva el dominio de la mercancía vendida hasta que el precio de la misma haya sido totalmente satisfecho. Hasta dicho momento, el cliente se obliga a manifestar ante terceros tal reserva de dominio, respondiendo de los daños y perjuicios que por omisión de esta obligación se ocasionen a Rafael Vallés Arándiga, S.L., y sin perjuicio de las responsabilidades en que pueda incurrir.
- Para cualquier cuestión derivada de la venta efectuada por Rafael Vallés Arándiga, S.L. serán competentes los Juzgados y Tribunales de la ciudad de Xàtiva.
- El modo de transporte será siempre a elección de Rafael Vallés Arándiga, S.L. Cuando el cliente elija otro medio de transporte diferente al ofrecido por Rafael Vallés Arándiga, S.L. los portes serán a su cargo.
- Salvo convenio especial, los plazos de entrega que se indiquen a los clientes tendrán carácter puramente informativo, y los retrasos o demoras que puedan producirse no darán derecho a indemnización.
- Toda tarifa de productos, general o específica, queda sujeta a modificaciones sin previo aviso.

Incidencias

- Rafael Vallés Arándiga, S.L. no acepta ninguna reclamación por aplicación errónea de sus productos.
- Todos los productos que sean suministrados por Rafael Vallés Arándiga, S.L. están garantizados contra cualquier defecto de

fabricación, cubriendo esta garantía la reposición del artículo defectuoso, pero no los portes que se originen. Esta garantía no cubre los defectos producidos como consecuencia de la mala utilización de la herramienta.

- No se aceptará reclamación alguna sobre la mercancía una vez transcurridas 24 horas desde la fecha de recepción de la misma.
- No se admitirán devoluciones transcurridos 15 días a partir de la fecha de entrega de la mercancía.
- Previamente a toda devolución es imprescindible la autorización por parte de Rafael Vallés Arándiga, S.L.
- En caso de haber devolución dentro del plazo estipulado y por motivos ajenos a Rafael Vallés Arándiga, S.L., será siempre a portes pagados por el cliente.
- El abono se realizará por el valor de la mercancía según los precios vigentes en la fecha de compra, reservándose Rafael Vallés Arándiga, S.L. el derecho de descontar de dicho abono el material deteriorado, así como los gastos de manipulación.
- Los artículos marcados bajo las siglas F.E. (Fabricación Especial) y B.P. (Bajo Pedido) en su descripción, no son susceptibles de devolución.
- Toda mercancía dañada por el medio de transporte (agencia) deberá ser notificada a ésta mediante la notificación en el albarán de recepción. De no ser así, Rafael Vallés Arándiga, S.L. no se hace responsable de dicha mercancía.

Facturación

- El importe de los abonos será descontado en la próxima factura que se produzca y notificado así al cliente.
- La primera venta realizada por Rafael Vallés Arándiga, S.L. hacia clientes nuevos será abonada mediante transferencia anticipada.
- Los gastos de devolución de documentos de cobro se realizarán a cargo del cliente.



Rafael Vallés Arándiga. S.L

HERRAMIENTAS PARA ESCAYOLA, CONSTRUCCIÓN Y BELLAS ARTES

Tel. 96 225 43 83 - Fax: 96 292 81 20

ventas@rafaelvalles.com - info@rafaelvalles.com

Partida Terrers s/n - Llanera de Ranes 46814 (Valencia)

www.rafaelvalles.com