



***Pando***  
integral*cooking*

**CAMPANAS DECORATIVAS**  
DECORATIVE COOKER HOODS

Collection  
2023





# Pando

integral*cooking*

## CAMPANAS DECORATIVAS DECORATIVE COOKER HOODS

### CALIDAD CERTIFICADA



Acceso PDF Tarifas  
Price list acces

(\*) El uso de la certificación y de la marca es exclusivo para los modelos marcados con este símbolo en su etiqueta identificativa.  
The use of the certification and the brand is exclusive for the models marked with this symbol on their identification tag.

**CREA TU  
ESPACIO DE  
CONFORT**



**CREATE  
YOUR COMFORT  
SPACE**

## CALIDAD | DISEÑO | INNOVACIÓN | ECO-EFICIENCIA

Después de más de 40 años en el mercado, para nosotros el lanzamiento de un nuevo catálogo de productos sigue siendo un reto en el que demostrar que somos capaces de superarlos y sorprender a nuestros clientes una vez más.

Pando es, y quiere seguir siendo, una empresa que se distingue por la CALIDAD, el DISEÑO y la INNOVACION. Una marca con un fuerte compromiso con sus orígenes y con la necesidad de aumentar el prestigio que ha conseguido gracias al trabajo de todo el equipo que la empuja.



## QUALITY | DESIGN | INNOVATION | ECO-EFFICIENCY

After more than 40 years in the market, the launch of a new catalogue still remains a challenge to us to prove that we are still able to do even better and excite our customers once more.

Pando is and will continue to be a company that stands out for QUALITY, DESIGN and INNOVATION. A brand with a strong commitment to its origins and the aspiration to increase the performance of its products and the satisfaction of its clients is the driving force of its whole team.

# CREA Y DIMENSIONA TU IDEA



## FABRICACIÓN PROPIA FABRICACIÓN A MEDIDA DISEÑOS DE VANGUARDIA

Solo un artesano como Pando puede hacer que cada diseño tenga una sensibilidad especial. Nuestra fabricación marca la diferencia en un mercado cada vez más igual y lineal, con productos que además de su atractivo diseño aportan confort, luz y color.

## OWN FABRICATION BESPOKE COOKER HOODS VANGUARD DESIGNS

Only real craftsmen, like Pando, can make each, design achieves a special sensitivity. Our manufacturing process sets the difference within a market that every day becomes more alike and uniform, by introducing products, that apart of their attractive design, also provide comfort, light and colour.





**CREATE  
AND SIZE  
YOUR IDEA**



**CREA, PERSONALIZA  
Y DA COLOR A  
TUS DISEÑOS**



**CREATE &  
CUSTOMIZE  
YOUR DESIGNS**

## NUEVOS MATERIALES NUEVOS COLORES NUEVOS DISEÑOS

Una propuesta muy personal al acabado de la campana.

La posibilidad de elegir un "color a la carta" o bien una textura explícita y acorde con el entorno de la cocina, o elegir materiales nobles con base de acero inoxidable de primera calidad y aplicar cobre o latón/dorado y así acercarte a lo más innovador y Vintage, es posible con esta colección.

Tu cocina es única y este será el toque especial y personal, que hará distinguirse del resto.

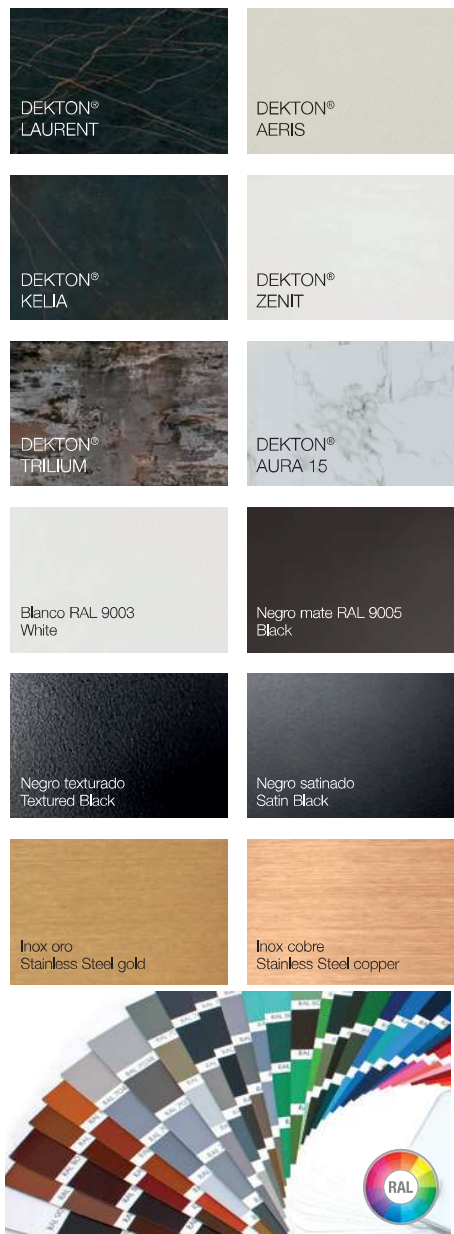

## NEW MATERIALS NEW COLOURS NEW DESIGNS

The opportunity to add a highly personal touch to the finish of your cooker hood. Choose a 'bespoke' colour or a particular texture to fit the surroundings of your kitchen, you could even choose copper or gold finishes on our top-quality stainless steel to achieve a chic or vintage look.

All options are possible with this collection.

Your kitchen is unique and this could be that special personal touch to make your kitchen stand out from the rest.



# ECO RESPONSABILIDAD PANDO

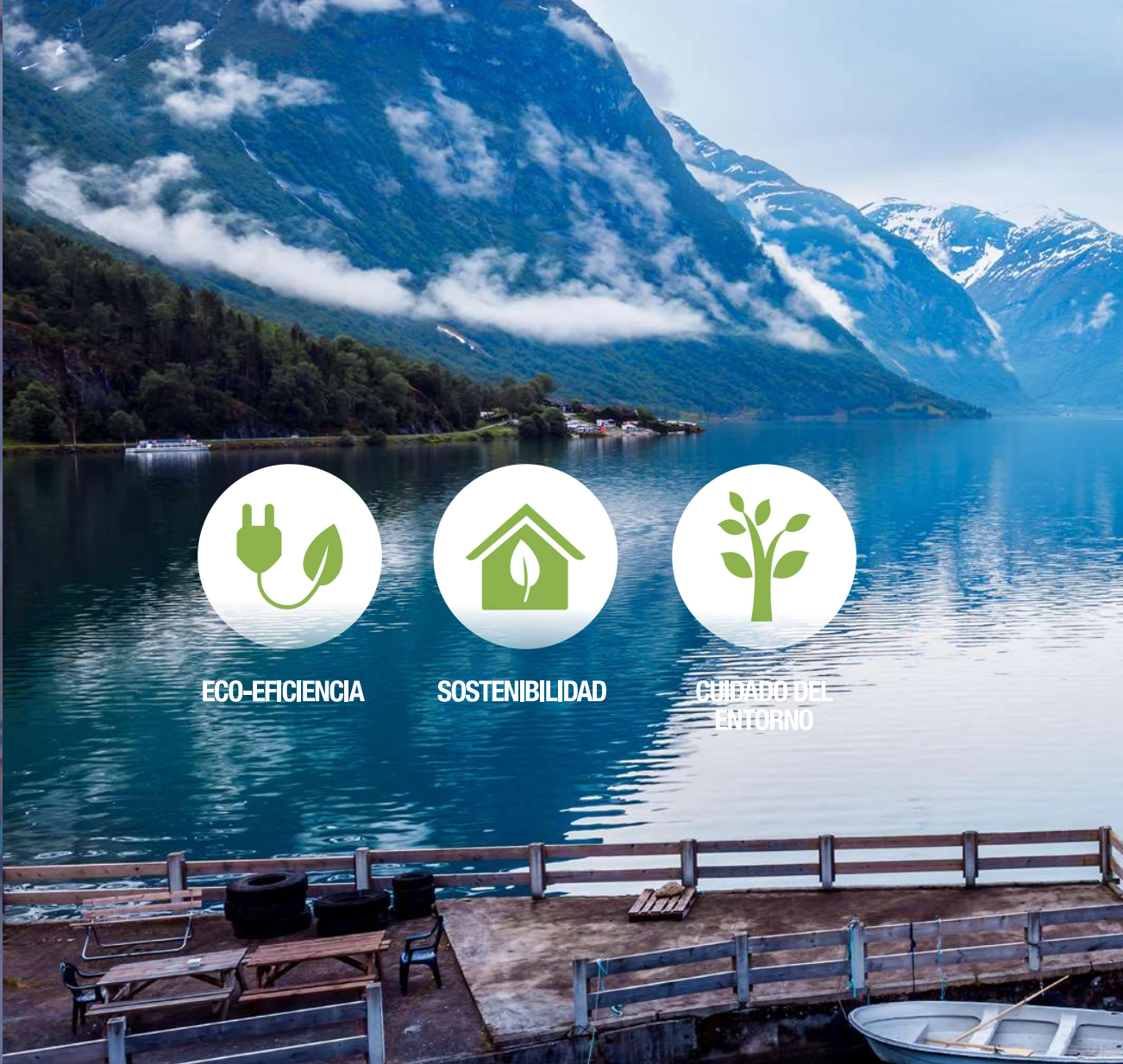

ECO-EFICIENCIA



SOSTENIBILIDAD



CUIDADO DEL  
ENTORNO

**PANDO**  
**ECO**  
RESPONSIBILITY

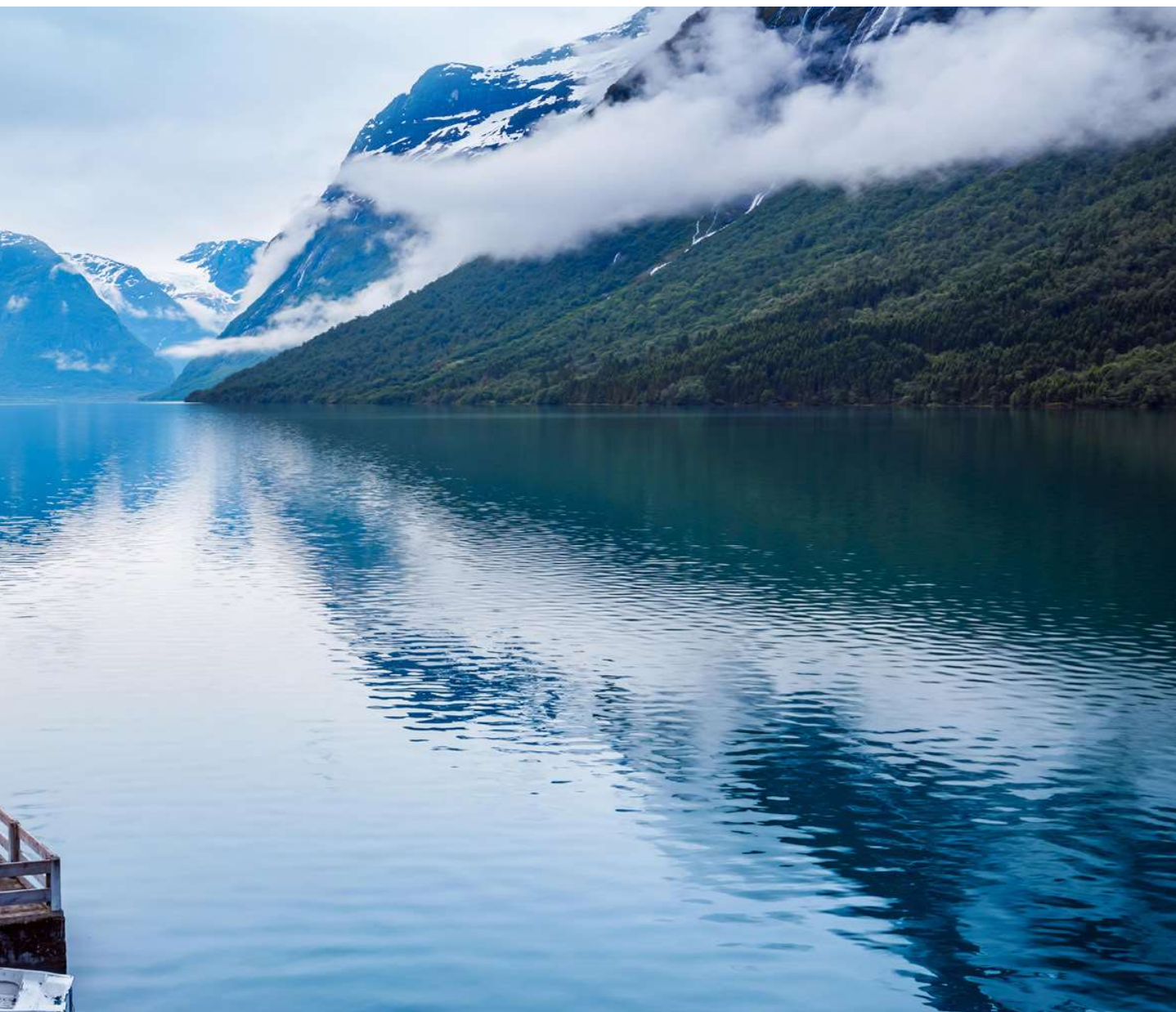

**SISTEMAS ECO RESPONSABLES  
PENSADOS PARA EL MÍNIMO CONSUMO,  
EL MÁXIMO CONFORT Y MÁXIMAS PRESTACIONES**

Pando refuerza su compromiso con sus clientes y con el medio ambiente con nuevas líneas de sistemas de altas prestaciones y mínimo consumo.

**SYSTEMS TO REDUCE  
ENERGY CONSUMPTION AND  
TO MAXIMIZE PERFORMANCE**

Pando reinforces its commitment to its customers and the environment with new high-performance systems and minimum power usage.



# DOBLE SISTEMA DE FÁCIL INSTALACIÓN

CAMPANAS DE TECHO PANDO



**DOUBLE EASY  
INSTALLATION  
SYSTEM**  
FOR PANDO CEILING HOODS





**Sistema de instalación con varillas roscadas.**

Este es el sistema más tradicional para el montaje de las campanas de techo. Previamente debemos instalar las varillas al techo ajustando la altura deseada. La instalación es tan sencilla como introducir las varillas por los orificios.

**Fitting System using rods.**

This one is the most traditional fitting system for ceiling units. Just before lifting up the unit the rods must be fixed to the concrete adjusting the right height. Installation is as simple as introducing the rods through the hood side corner holes.



**Sistema de instalación con grapas directamente a falso techo**

La zona de anclaje, se deberá reforzar previamente en relación al peso de la campana de techo a instalar.

**Fitting System using fixing metal clamps directly into the false ceiling**

The gripping area previously needs to be reinforced based on ceiling hood weight to be installed.

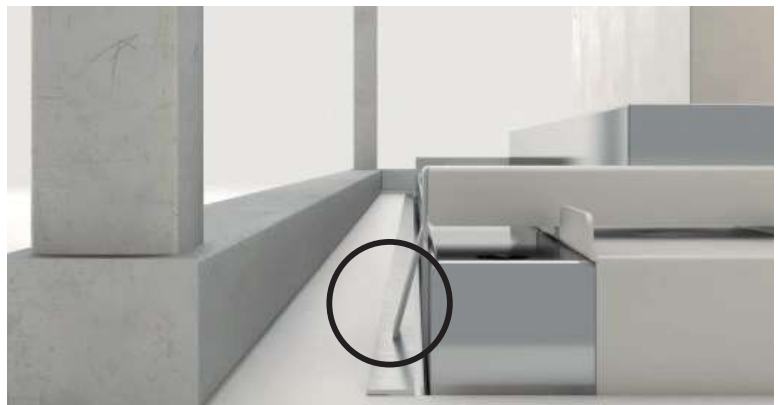

**Box-motor giratorio** que permite el cambio de dirección de la salida del aire, facilitando de esta forma su instalación.

**Rotary motor-box** allowing airflow exit side change, and making fitting easier this way.



**Cambio del sentido de la apertura de la puerta inferior**

Gracias a este sistema, podremos cambiar el sentido de apertura de la puerta inferior dependiendo de la orientación que nos sea más favorable en el momento de su instalación.

**Change of door opening direction**

By using this system we can change the door opening direction during the installation according to our needs.

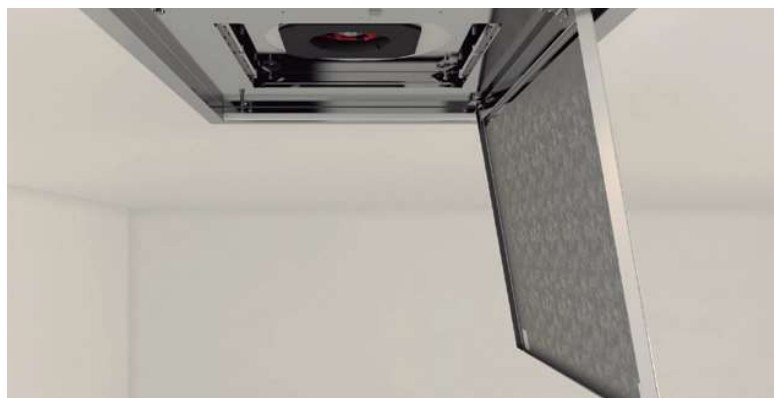

SISTEMAS DE  
**FÁCIL INSTALACIÓN**

SYSTEMS FOR  
**EASY INSTALLATION**

## Campanas de Pared

NUEVO SISTEMA CON AJUSTE DE  
FIJACIÓN ULTRARRÁPIDO

## Wall cooker hoods

NEW SYSTEM FOR ULTRA FAST AND  
EASY INSTALLATION

## S.E.C. System® PLUS

V.1050 ECO

## Campanas de Integración

MÁXIMA PROTECCIÓN DEL MUEBLE

## Built in Hoods

CABINET PROTECTION.

## Modelos/Models TIM-2, TIX

## Campanas sobre encimera

PERMITE APROVECHAR EL ESPACIO AL MÁXIMO

## Worktop cooker hoods

ENSURES OPTIMAL USE OF SPACE

## REGULABLE HORIZONTAL Y VERTICALMENTE

Nuevo sistema de anclaje a pared que nos permite una fijación regulable y rápida de la campana y así adaptarse al máximo a las necesidades de la instalación.

## ADJUSTABLE HORIZONTALLY AND VERTICALLY

New wall clamping system providing an adjustable and fast fixing of the hood.

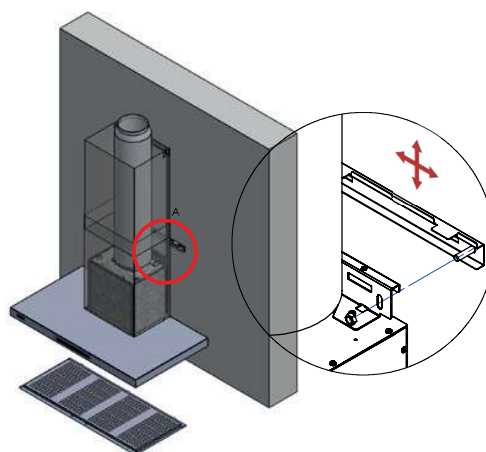

## PROTECCIÓN DEL MUEBLE

### ADAPTABILIDAD

Fácil instalación y montaje gracias a no tener que recortar el mueble. También se adapta al fondo del mueble para su completa integración.

### TUBO EMBELLECEDOR

Protección total del motor y de la parte electrónica, permitiendo también aprovechar al máximo el almacenamiento del mueble.

## CABINET PROTECTION

### ADAPTABILITY

Easy installation and fitting with out the need to cut the furniture. Also adaptable to cabinet depth to allow precise fitting.

### CHIMNEY EXTENSION

Designed to Offer total protection for the motor and electronics while maximising interior cabinet space.

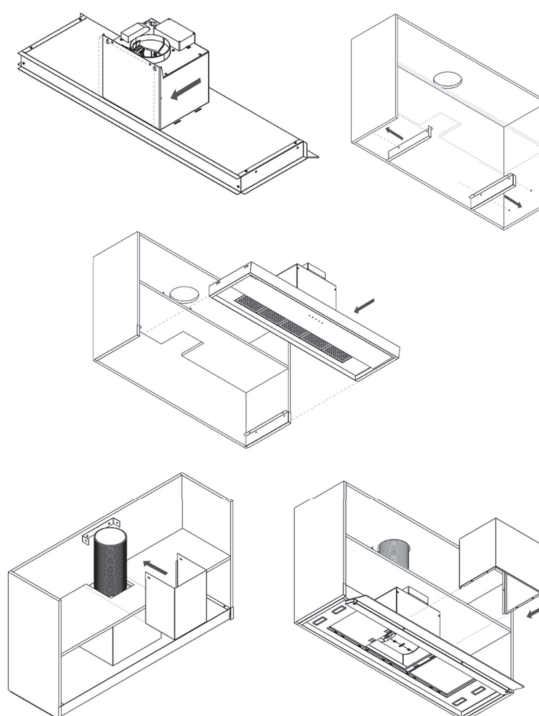

## APROVECHAMIENTO TOTAL DEL ESPACIO INTERIOR

Diseño único de la conducción de humos que permite aprovechar al máximo el espacio útil del mueble para incorporar cajones con fondo de 500 mm.

## FULL USE OF THE INTERIOR SPACE

Unique design of smoke extraction offering best-in-class use of the available space in the furniture to allow that 500 mm deep drawers can be installed.

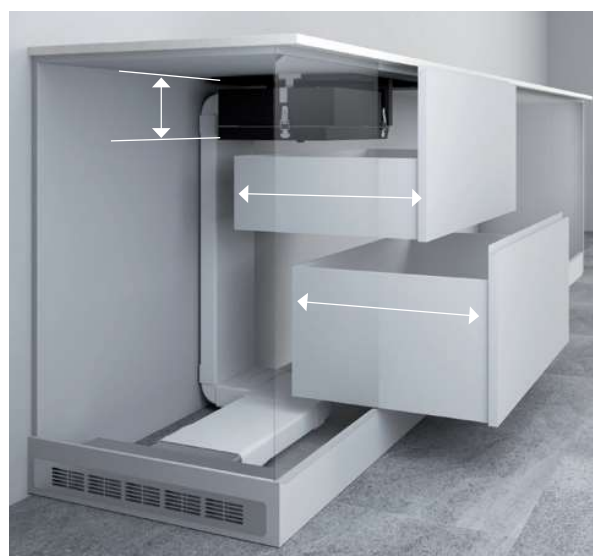

ESTRUCTURAS Y FORMAS QUE DISPONEN DE ALTA TECNOLOGÍA, PARA DISFRUTAR AL MÁXIMO DE SU COCINA.

outside

OPTIMAL STRUCTURE AND SHAPES ALONG WITH BEST OF TECHNOLOGIES FOR YOU TO ENJOY AN OUTSTANDING DECORATIVE COOKER HOOD.

NUUESTRA  
TECNOLOGÍA

OUR  
TECNOLOGY



1

**ADAPTABILIDAD**  
SOMOS FABRICANTES

**ADAPTABILITY**  
WE ARE MANUFACTURERS

2

**INNOVACIÓN**  
AirLink by Pando

**INNOVATION**  
AirLink by Pando

3

**ILUMINACIÓN**  
SISTEMA PANDO LED

**LIGHTING**  
PANDO LED SYSTEM

4

**SOLUCIONES DE AIRE FILTRADO**  
SISTEMAS RECIRCULACIÓN

**SOLUTIONS FOR FILTERING OF AIR**  
RECIRCULATION SYSTEMS

5

**CONFORT Y SILENCIO**

**COMFORT & SILENCE**



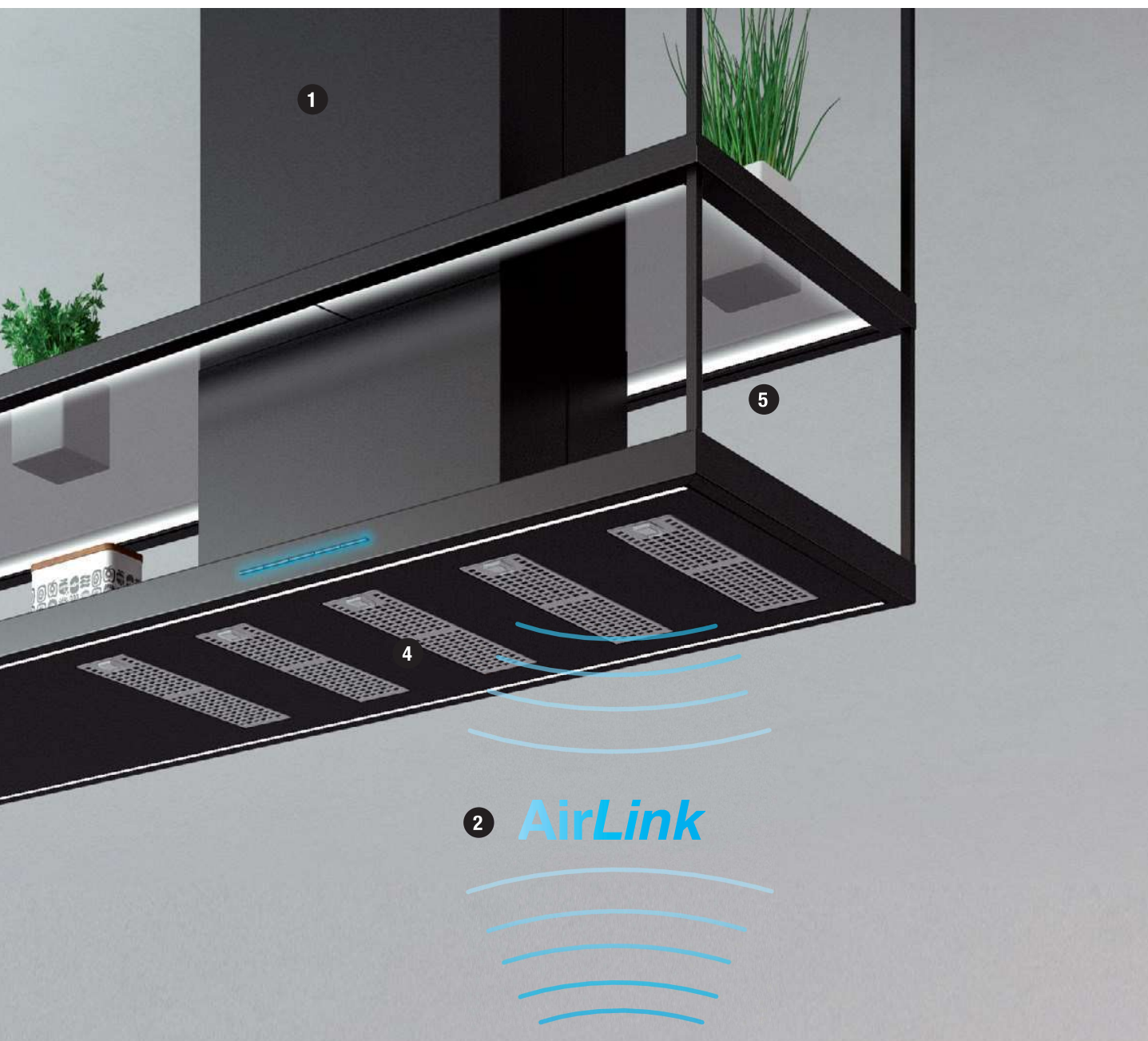

1

Nuestra experiencia y "Know How" nos permiten elaborar productos específicos para catálogo y para proyectos especiales, donde podremos elegir: MATERIAL, FORMA, DIMENSIÓN y COLOR.

Our experience and "know-how" allows us to offer bespoke solutions for catalogue and orientated to special projects, where it is possible to choose from: MATERIAL, SHAPE, SIZES and FINISH.

2

Sistema inteligente de interconexión entre campana y placa de inducción.

Smart intercom system between Ceiling hood and our cooktops.

3

Todos los sistemas de luz son mediante LED de Alta Eficiencia. Pando LED: Control de intensidad y temperatura de color.

All lighting systems are based on high efficiency LEDs. Pando LED: adjusting brightness and colour temperature.

4

Diferentes tipos de filtros, garantizan la máxima eficacia en la captación de grasas y aceites de cocción. Aluminio de Aleación Ligera, Inoxidables de hasta 9 capas, filtros profesionales de laberinto filtros cerámicos, FCLR AE

Different types of filters guarantee a maximum efficiency in grease and cooking oils collection. Light Aluminium alloy, S/Steel filters up to 9 layers, professional baffled filters, and FCLR-AE.

5

Somos conscientes de lo importante que es el silencio para mantener un ambiente agradable y armónico en un hogar. Por este motivo, nuestros motores tienen una reducción sonora de hasta un 20%.

We are aware of how important it is to provide silence and to keep a pleasant as well as harmonic atmosphere at home, for this reason our motors include a noise reduction of up to 20%.



NUESTRA  
**TECNOLOGÍA**

OUR  
**TECNOLOGY**

**AirLink**

# MÁS COMODIDAD

SISTEMA DE CONTROL INTELIGENTE DE FUNCIONAMIENTO  
COMBINADO DE CAMPANA Y PLACA DE INDUCCIÓN.

# MORE COMFORT

SMART CONTROL SYSTEM TO COMBINE COOKER HOOD  
AND INDUCTION HOB FUNCTIONS.



- Conexión de la iluminación al conectar la placa.
- Puesta en marcha del motor al iniciar el ciclo de cocción de cualquier inductor.
- Aumento y disminución de la potencia del motor de la campana, en función de la exigencia de potencia que se ordene al inductor de la placa.
- Opción de control manual de todas las funciones de la campana.

#### RECOMENDACIONES DEL SISTEMA

La campana y la inducción, deben instalarse en la misma línea de corriente.

Sistema Airlink únicamente para pedidos de campana y placa conjuntamente.

Sistema Airlink de venta exclusiva en estudios y tiendas de mueble de cocina.

La Campana y la Placa deben sincronizarse, por lo que deben ser totalmente compatibles. (Consulte qué Campanas y Placas permiten utilizar el sistema AirLink).

- Light turns on automatically when hob is connected.
- Motor starts automatically when cooking cycle begins on any part of the hob.
- Motor powers up or down, depending on the power level set on the cooktop.
- All hood functions can also be controlled manually.

#### SYSTEM RECOMENDATIONS

The hood and the induction hob must be installed using the same power line.

The Airlink system works only for hood-hob sets placed in the same purchase order.

The Airlink system is for sale exclusively in Design Studios and Kitchen retail Studios. Hood and Hob must be synchronized, so they ought to be compatible.

(Please check what hoods and hobs are compatible with this system).

NUUESTRA  
**TECNOLOGÍA**

OUR  
**TECNOLOGY**

# *Pando* LED



LA **ILUMINACIÓN**  
A TU GUSTO

CHOOSE YOUR  
**OWN LIGHT**



## SISTEMA DE PERSONALIZACIÓN DE LA ILUMINACIÓN LED

La iluminación por excelencia de última generación, con la que se pueden crear multitud de ambientes, con excelente ahorro energético. La iluminación de referencia en los productos Pando.

Atenuador electrónico que regula la energía que se suministra a la lámpara LED con el fin de variar la intensidad de luz que emite. Nos permite adecuar la luminosidad que emite la campana a nuestra necesidad del momento, desde un modo intenso de trabajo hasta uno tenue a modo ambiental, ahorrando consumo y energía.

## CUSTOMIZED LED LIGHTING SYSTEM

Pando LED: the ultimate last-generation LED lighting, it can be used to create a multitude of individual atmospheres, with excellent energy-saving performance. The reference in lighting of Pando products.

Electronic LED lighting Dimming Device for energy emission and light regulation. This makes it possible to adapt intensity and color to any working light mood and energy saving level.  
Candle light / Twilight / direct sun light / clear day / Pale Blue Sky.

NUESTRA  
TECNOLOGÍA

OUR  
TECNOLOGY

## SOLUCIONES DE AIRE FILTRADO

### SISTEMAS DE RECIRCULACIÓN

## AIR FILTERING SOLUTIONS

### RECIRCULATION SYSTEMS

#### CAMPANAS DE PARED E ISLA WALL & ISLAND COOKER HOODS

1.- Recirculación clásica en pared e islas  
(salida por la rejilla del tubo de la campana)

Classic recirculation for wall and island  
units (exit through the side grill in the HOOD  
CHIMNEY)

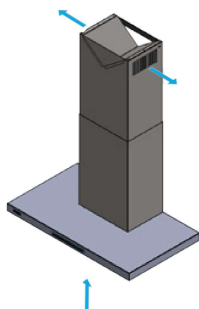

#### CAMPANAS DE TECHO CEILING COOKER HOODS

2.- Sistema de Recirculación mediante  
Filtros Cerámicos de Alta Eficiencia a través  
de Difusor de techo o FCLR-AE

Recirculation system using high-efficiency  
ceramic filters through a CEILING DIFFUSER.

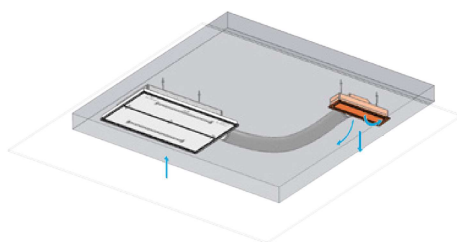

#### CAMPANAS SOBRE ENCIMERA WORKTOP INTEGRATED COOKER HOODS

3.- Sistema de Recirculación mediante Filtros  
Cerámicos de Alta Eficiencia a través de Difusor a  
ZÓCALO o FCLR-AE

Recirculation system using high-efficiency ceramic  
filters through a PLINTH DIFFUSER.

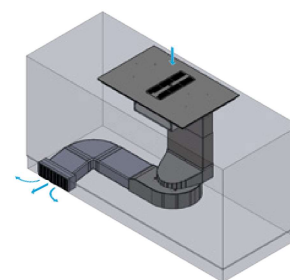

## Durabilidad de los filtros / Duration of the filters

### Eficiencia y mantenimiento de los filtros de carbón activado Carbon Filters: Efficiency and Maintenance Chart



Tipo de filtro Filter type	% de factor de reducción de los olores Smell reduction percentage factor	Durabilidad de los filtros Filter life	Lavables Washable	Reactivables Reactivatable
HEPA	99,9% Partículas+Olores / Particles+Odours	8 - 12 meses / months	NO	NO
FCA	40,8%	2 - 6 meses / months	NO	NO
FCLR AE (1)*	87,4%	2 años / years	SI / YES	SI / YES
FCCR AE (2)*	95,0%	3 años / years	NO	SI / YES

(1) Reactivación en horno a 90° durante 60 minutos  
Reactivate in an oven at 90° for 60 minutes

(2) Reactivación en horno a 180° durante 120 minutos  
Reactivate in an oven at 180° for 120 minutes



## HEPA



### High-Efficiency Particulate Air

Filtros HEPA (High-Efficiency Particulate Air, literalmente: "atrapador de partículas de alta eficiencia")

Máxima eficiencia de filtración. Están considerados los filtros con mayor eliminación de partículas suspendidas en el aire. Se calcula que pueden llegar a atrapar más del 99% de estas partículas de hasta 0,3 micrómetros de diámetro.

Su composición mediante el plegado de fibras de vidrio micrométricas entramadas en forma de red junto con la fusión de carbón activo de Alta Eficiencia, los hacen ideales para aquellas campanas con sistema de recirculación porque además de atrapar la concentración de las partículas suspendidas en el aire, es realmente eficaz capturando las partículas causantes de los malos olores garantizando un retorno de aire limpio a la cocina.

La vida útil de este tipo de filtros depende en gran medida de la frecuencia, el método y la intensidad de cocción. Por ello podemos asumir valores medios entre 8-12 meses de uso. Una vez pasado este plazo, se deberá reemplazar.

### High-Efficiency Particulate Air

HEPA filters (High-Efficiency Particulate Air)

Maximum extraction efficiency. They are the most effective filters for the removal of particles suspended in the air. It is calculated that they can trap more than 99% of these particles down to 0.3 micrometres in diameter.

Their composition by means of the folding of micrometric glass fibres interwoven in the form of a net together with the fusion of High Efficiency active carbon, make them ideal for those hoods with a recirculation system because as well as trapping the concentration of particles suspended in the air, they are really effective at capturing the particles that cause bad smells, guaranteeing a return of clean air to the kitchen.

The service life of this type of filter depends to a large extent on the frequency, method and intensity of cooking. Therefore, we can only assume average values of 8-12 months of use. Once this period has elapsed, it must be replaced.

## FCA



### Filtros Carbón activado

Indicados para las campanas destinadas a la recirculación de los gases de cocción o bien con fines medioambientales. Su efectividad va ligada directamente a la tipología de cocinados que se realicen.

### Activated carbon Filters

Suitable for recirculating cooking gases or also for environmental purposes. Their effectiveness is directly related to the kind of cooking done.

## FCLR-AE



### Filtro de Carbón Activado Lavables y Reactivables de ALTA EFICIENCIA

Muy superiores en funcionalidad a los FCA, estos nuevos filtros de ALTA EFICIENCIA (FCLR-AE) logran resultados excelentes en sistemas de recirculación. Además tienen la gran ventaja, gracias a su especial composición y fabricación, de permitir su lavado en lavavajillas y su posterior reactivación en horno. Su durabilidad puede incrementarse por encima de los 2 años, dependiendo también del tipo de cocción y mantenimiento.

### HIGH-EFFICIENCY washable and reactivated carbon filters

Far superior in performance vs the FCA system, these new HIGH-EFFICIENCY CARBON FILTERS (FCLR-AE) provide excellent results. Thanks to their special material they also be dish-washed and reactivated in the oven. They can last over 2 years, depending on the maintenance and type of cooking.

## FCCR-AE



### Filtro de Carbón Activado Cerámico Reactivable de ALTA EFICIENCIA

Aún más eficaces que los FCLR-AE, son estos filtros de última generación CERÁMICOS de ALTA EFICIENCIA (FCCR) que logran mejores resultados de recirculación. Tienen la excelencia, debido a su específica construcción, de permitir su reactivación en múltiples ocasiones en el horno. Su durabilidad es enorme y supera con creces los 3 años. Es muy importante para ello un buen mantenimiento.

### HIGH-EFFICIENCY reactivatable ceramic active carbon filter

Even more efficient than the FCLR-AE, these last-generation HIGH-EFFICIENCY CERAMIC filters (FCCR-AE) achieve enhanced results in recirculation. Their specific construction gives them the enormous advantage so they can be reactivated several times in the oven. They are extremely resistant and can easily last over 3 years. A fine maintenance is of key importance.

NUESTRA  
TECNOLOGÍA

OUR  
TECNOLOGY

# SOLUCIONES DE AIRE PURO

## SISTEMAS DE FILTROS



# PURE AIR SOLUTIONS

## PANDO FILTERS



### FILTROS DE 9 CAPAS

Mayor absorción de grasas  
Mayor velocidad de aspiración  
Reducción de la sonoridad  
Tamaño idóneo para su limpieza en el lavavajillas

### FILTERS OF 9 LAYERS:

Higher grease absorption  
Higher extraction airflow speed  
Noise reduction  
Ideal size for dishwasher cleaning



### FILTROS DE ALUMINIO:

Realizados en aleación ligera, son esenciales para la captación de partículas grasas y la retención de las mismas. Su particular malla los hace especialmente útiles.

### FILTROS INOXIDABLES:

Están fabricados idénticamente a los de aluminio pero además incorporan una cobertura en acero inoxidable que los protege y alarga la vida útil, al mismo tiempo que los embellece.

### FILTROS DE LABERINTO O PROFESIONALES:

Realizados total y únicamente en acero inoxidable de primera calidad AISI 304, estos filtros están preparados para el duro trabajo y las altas prestaciones de retención de grasas. Su durabilidad es enorme, lo mismo que sus prestaciones totalmente profesionales.

### DETECCIÓN AUTOMÁTICA DE SATURACIÓN DE FILTROS

Sistema automático que informa de cuando es imprescindible la limpieza de los filtros, a través de una señal en la botonera de control.

### ALUMINIUM FILTERS

Made of light alloy, these are essential to capture and retain fat particles. Their distinctive grille pattern makes them especially useful.

### STAINLESS STEEL FILTERS

Made identically as the aluminium ones, but they additionally feature a stainless steel cover to protect them and extend their useful life, as well as making them look more attractive.

### LABYRINTH OR PROFESSIONAL FILTERS

Made entirely in top-quality AISI 304 stainless steel, these filters are ready to work hard and display their good fat particle retention strategies. Enormously durable, their features are 100% professional.

### AUTOMATIC FILTER SATURATION DETECTION

Automatic system warns you when filters need to be cleaned, via a signal on the control panel.



DESARROLLAMOS SISTEMAS DE EXTRACCIÓN DE ALTO RENDIMIENTO, CON EL MÍNIMO CONSUMO. TODAS LAS SOLUCIONES, SOMOS ESPECIALISTAS.

inside

WE ARE EXPERTS: HIGHEST EXTRACTION LEVELS ON A MINIMUM ENERGY CONSUMPTION



Motores interiores / Internal motors



Motores intermedios / Duct-in-line remote motors



Motores de tejado / Roof motors



Motores mural / Outdoor Wall Motors

1	<b>VERSATILIDAD</b> MOTORIZACIONES E INSTALACIONES	<b>VERSATILITY</b> MOTORIZATIONS & INSTALLATION
2	<b>EFICIENCIA</b> SEC System y SEC PLUS de Pando	<b>EFFICIENCY</b> SEC System and SEC PLUS by Pando
3	<b>AIRE LIMPIO</b> SISTEMAS DE RECIRCULACIÓN Y FILTROS DE CARBÓN ACTIVADO	<b>CLEAN AIR SOLUTIONS</b> RECIRCULATION SYSTEMS AND ACTIVATED CARBON FILTERS
4	<b>FACILIDAD</b> SISTEMAS DE FÁCIL MONTAJE	<b>EASY INSTALLATION</b> EASY ASSEMBLING SYSTEMS
5	<b>SEGURIDAD</b> SISTEMAS ELECTRÓNICOS DE SEGURIDAD	<b>SAFETY</b> ELECTRONIC SAFETY SYSTEMS

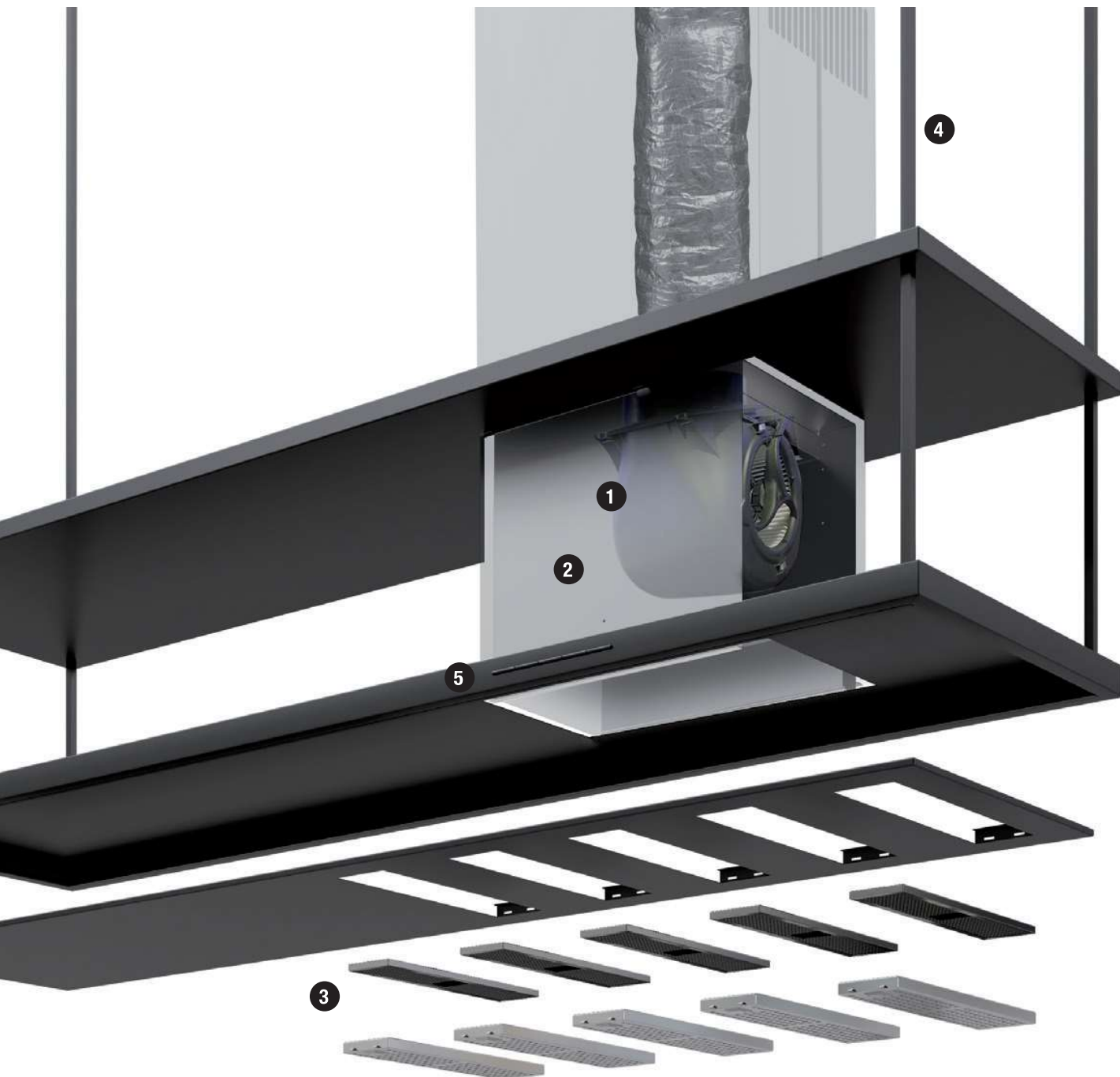

1

Compuesta por 20 unidades diferentes de motores, más adicionalmente, los requeridos para proyectos especiales, con distintas opciones de instalación.

Composed of 20 different motor types, plus additionally, those required for special projects, with different options for its installation.

2

Nuevos sistemas que permiten máxima eficacia, mínimo consumo y máxima insonorización.

New systems allowing maximum efficiency, minimum energy consumption and maximum noise reduction.

3

Usamos distintos tipos de filtro de carbón activado que permiten una limpieza del aire de recirculación.

We use different types of activated carbon filters providing a best-in-class cleaning of recirculated air.

4

Sistemas de fácil montaje para todos los tipos de campanas: ADS QUICK FIX, I-FIX, SEC PLUS...

Easy assembling systems for all type of extractor hoods: ADS QUICK FIX, I-FIX, SEC PLUS...

5

Sistemas de seguridad de apagado automático y sistemas anti-atrapamiento

Automatic safety switch off systems and entrapment-free systems

NUESTRA  
TECNOLOGÍA

OUR  
TECHNOLOGY

SEC SYSTEM®

MÁS  
CONFORT Y  
EFICIENCIA

MORE  
COMFORT &  
EFFICIENCY



# S.E.C. System®

## Insonorización y fácil limpieza

### Sistema de fácil limpieza

1. Blindaje interior a través de bandeja interna, acabada en acero inoxidable, para su fácil limpieza.
2. Rejilla interna protectora de doble acción.

### Sistema de insonorización

3. Motores de última generación integrados en el chasis de la campana con doble turbina de gran diámetro, sustentada por eje central y doble silent-block.
4. Box de ubicación del motor aislado con espumado especial fonoabsorbente, ignífugo y anti-grasa.
5. Tubo flexible de 50cm con doble cámara, realizado en película de aluminio fonoabsorbente y micro-poro.



## Soundproof & easy cleaning

### Easy Cleaning System®

1. Lower tray made of stainless steel for easy cleaning.
2. Double-function internal protective grille.

### Soundproof System®

3. New internal motors. Metal wheel and silent block on center shaft.
4. Motor-housing box insulated with sound absorbent, fireproof, grease-resistant foam.
5. Includes 50cm flexible corrugated tube made of sound absorbent, double-chamber, micropore aluminium film.

# S.E.C. System® PLUS

V.1050 ECO

## Todas las características del sistema S.E.C. System® y además:

6. Nuevo aislamiento especial fonoabsorbente
7. Nuevo box que mejora el rendimiento del motor
8. Nuevo sistema con ajuste de fijación ultrarrápido
9. Nuevos silent-block que amortiguan las vibraciones
10. Chasis reforzado y más rígido que garantiza mejor el sellado acústico
11. Nuevos alerones especiales aerodinámicos

## All the features of the S.E.C. System® and:

6. New noise-deadening insulation
7. New box to improve motor performance
8. New system with ultra-rapid fixing adjustment
9. New silent block to reduce vibrations
10. Reinforced, more rigid chassis to ensure better noise containment
11. New special aerodynamic flaps

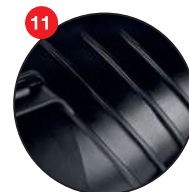
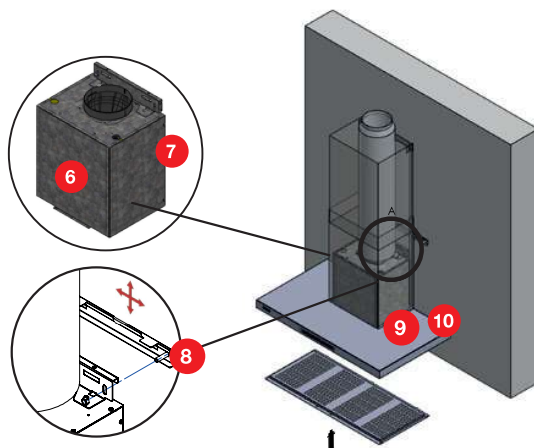

Nueva aerodinámica  
New aerodynamic

NUESTRA  
TECNOLOGÍA

OUR  
TECHNOLOGY

MOTORES  
DE GRAN  
VERSATILIDAD

MOTORS  
HIGH  
VERSATILITY

## TIPOS DE MOTOR MOTORES ECO EFICIENTES

**MÁXIMAS PRESTACIONES  
MÍNIMO CONSUMO  
EXCELENTE NIVEL SONORO**

Pando tiene distintas soluciones en sistemas de motorización para adaptarse perfectamente a su proyecto y facilitar al máximo la instalación. Muchos de nuestros sistemas de motores incorporan sistemas ECO eficientes, de gran rendimiento y muy bajo nivel sonoro.

**Versatilidad, adaptabilidad y máximo confort de uso.**

## MOTOR VERSIONS. ECO EFFICIENT MOTORS

**MAXIMUM PERFORMANCE WITH  
MINIMUM ENERGY CONSUMPTION  
AND EXCELLENT SOUND LEVELS**

Pando offer a choice of high-performance motor solutions, with easy installation so allowing you to perfectly adapt our products for ultimate performance.

Many of our motor systems feature ECO efficient devices, offering high performance at very low noise levels.

**Versatility, adaptability and maximum convenience.**

## Motores interiores Internal motors

Motores instalados dentro del cuerpo de la campana.  
Muchas de las versiones incorporan sistemas ECO eficientes y de gran rendimiento y bajo nivel sonoro.  
El sistema V.1050 proporciona una reducción sonora de hasta un 20%.  
V.1130 ECO PLUS consigue hasta un 57% más de caudal y mejora de presión en conducto.

Motors fitted inside the hood casing.  
Many of the versions feature ECO efficient systems offering high performance at very low noise levels.  
The V.1050 system offers up to 20% noise reduction  
The V.1130 ECO PLUS achieves up to 57% higher flow and improved pressure in the pipe



## Motores intermedios Duct-in-line remote motor

Motores intermedios de colocación fuera del chasis de la campana. Pueden instalarse en falso techo o bajo cubierta. No pueden instalarse a la intemperie.  
Gran capacidad de extracción sin ruido.

**INCLUIDO**  
Las unidades con motorizaciones V.2450 y V.3000 Intermedio Exterior incorporan de serie 5 m de tubo de extracción de humos SEC System® de Ø203 mm interior y Ø253 mm exterior.

Duct-in-line remote motors fitted separately from the hood chassis.  
They can be mounted on a false ceiling or under the roof. They cannot be installed outdoors. High extraction capacity and without noise.

**INCLUIDO**  
The models with the V.2450 and V.3000 duct-in-line remote motor comes with 5 m of S.E.C. fume extractor flue as standard System®, interior Ø 203 mm and exterior Ø 253.

## Motores de tejado Roof motors

Motores para su colocación en tejado. Totalmente preparados para cualquier inclemencia del tiempo. Gran capacidad de extracción sin ruido.

**INCLUIDO**  
Las unidades con motorizaciones V.2350 y V.3300 Tejado, incorporan de serie 5 m de tubo de extracción de humos SEC System® de Ø203 mm interior y Ø253 mm exterior.

Motors for mounting on the roof top of the house. Suitable for all weathers.  
High extraction capacity with no noise.

**INCLUIDO**  
The models with the V.2350 and V.3300 Roof motor system, comes with 5 m of S.E.C. fume extractor flue as standard System®, interior Ø 203 mm and exterior Ø 253.

## Motores mural Wall motors

Motores para su colocación adosados al muro exterior de la casa. Totalmente preparados para cualquier inclemencia del tiempo. Gran capacidad de extracción sin ruido.

Motors for mounting on the outside wall of the house.  
Suitable for all weathers.  
High extraction capacity with no noise.

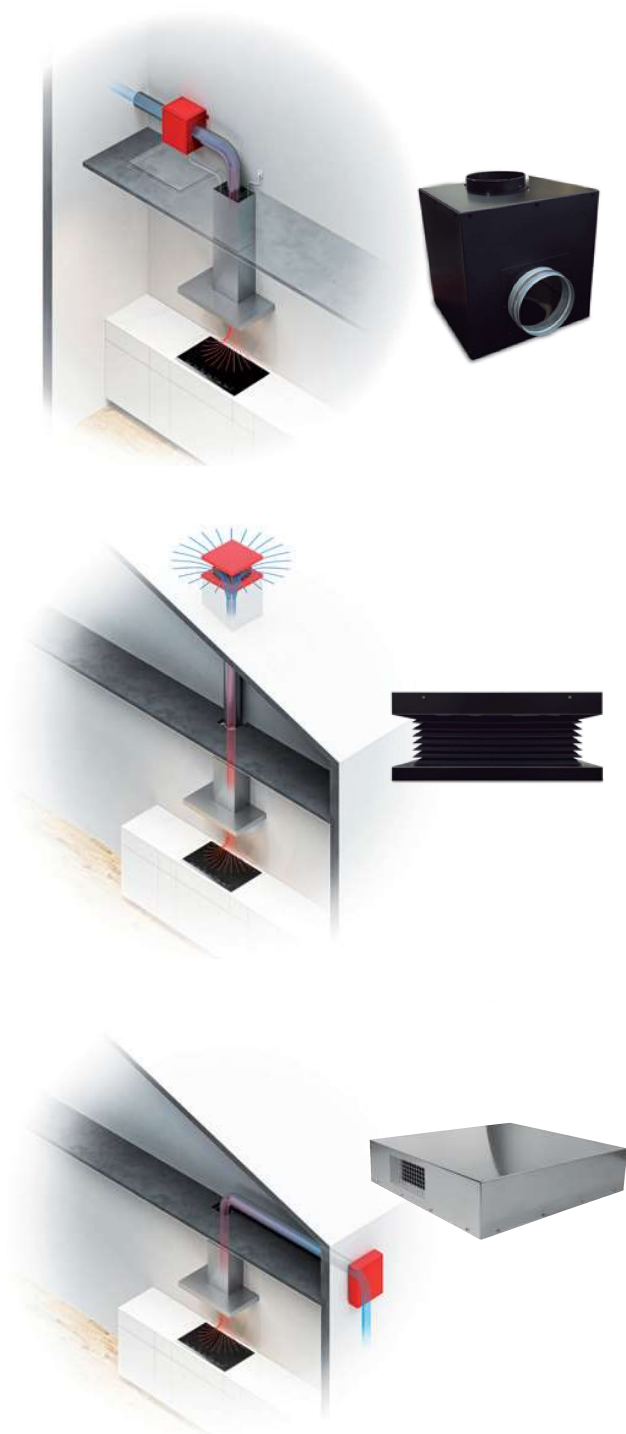



NUESTRA  
TECNOLOGÍA

OUR  
TECNOLOGY

SISTEMAS DE CONTROL  
**FACILIDAD  
DE USO**

**CONTROL, DISEÑO Y  
FUNCIONALIDAD**

Botonera Electrónica  
Electronic button panel

CONTROL PANELS  
**EASY-TO-USE**

**CONTROL, DESIGN  
AND FUNCTIONALITY**



### BOTONERAS ELECTRÓNICAS Y TOUCH CONTROL

Botoneras de control que incorporan nuestros equipos, en función de la dotación de cada modelo, para la selección de la velocidad, iluminación etc.

Con apagado automático de seguridad.

### FUNCIONALIDAD LAST-TIME

Sistema de apagado automático, que incorporan una amplia gama de modelos. Al pulsar esta función la campana se para automáticamente pasado unos minutos después de su uso, para garantizar la total extracción de los humos del conducto de salida.

### MANDO A DISTANCIA

Sistema de control remoto de los controles de la campana.

Se incorpora de serie en todos los modelos de Techo y es opcional en muchos otros equipos.

Con apagado automático de seguridad.

### BOTONERA DE ENCASTRE A PARED

Ahora todas las campanas de techo pueden incorporar de forma opcional, una botonera de control de la campana encastrada a pared. El sistema incorpora de serie un cableado máximo de 10 m.

(\*) Excepto E-237



Botonera de encastre a pared para campanas de techo  
Button panel for wall inset mounting



Mando a distancia Touch Control  
Remote Touch Control

### ELECTRONIC BUTTON PANELS AND TOUCH CONTROL

The control panels featured on our units, depending on the characteristics of each model, can be used to control the speed, lighting etc.

It includes an automatic safety stop.

### LAST-TIME FUNCTION

An automatic stop system available on a wide range of models. When this function is activated the hood stops automatically a few minutes after it is used, to ensure that any remaining fume is also extracted.

### REMOTE TOUCH CONTROL

Remote control system for the hood functions. This is standard for all Ceiling models and optional for many others. It includes an automatic safety stop.

### BUTTON PANEL FOR WALL INSET MOUNTING

All ceiling-mounted models can now benefit from a new optional feature: a control button panel for the hood set into the wall.

The system comes with up to 10 m of cabling as standard.

(\*) Except E-237



Longitud frontal de la campana  
Hood front length



Incorpora sistema S.E.C. Sytem® Plus  
Features S.E.C. System®Plus



Sistemas ecoeficientes en ahorro energético  
Eco-efficient systems for energy savings



Campanas realizadas con Acero Inoxidable según norma AISI clasificación 304  
Hoods manufactured with Stainless Steel in accordance with AISI standard classification 304



Tipo de botonera: Touch, slider, electrónica,  
Type of control: Touch, slider, electronic



Incorpora mando a distancia de serie  
Includes remote control as standard



Función Last Time que permite dejar la campana en funcionamiento un tiempo establecido hasta su apagado automático.  
Last Time function with automatic Hood turn off.



Tipo de material de los filtros  
Type of filter



Filtros de carbón activado, filtros de carbón activado reactivables y Filtros HEPA  
Activated carbon filters



Sistema con detección automática de saturación de filtros  
System with of filter saturation automatic detection



Tipo de la iluminación principal, temperatura de color y iluminación de cortesía o ambiente.  
Temperatura de color de la iluminación principal.  
Type of main lighting and courtesy lighting



Sistema de iluminación LED dimmable en intensidad y temperatura de la luz  
Dimmable LED lighting in temperature and intensity



Iluminación regulable en intensidad | Ajuste del color del LED 2700K a 6000K.  
Dimmable LED lighting in intensity | LED color adjustment 2700K to 6000K.



Sistema Inteligente de Seguridad de apagado automático (by Pando)  
Features smart automatic safety stop system (by Pando)



Distancia recomendada entre la campana y la zona de cocción  
Recommended distance between cooker hood and cooktop



Distancia recomendada entre la campana y la zona de cocción según esta sea de gas o inducción  
Recommended distance between cooker hood and cooktop depending on being gas or induction



Nuevo sistema de fácil instalación de campanas de techo  
New hood gripping system making easier installing and fixing the hood into the recessed ceiling



Sistema automático de funcionamiento del motor durante 10 min. cada hora, durante 5 o 24 h.  
Automatic working motor system for 10 minutes every hour during 5 or 24 hours.



Personalizable con todos los colores de la carta RAL  
Custom made on any colour from the RAL chart



# ÍNDICE

## INDEX

CAMPANAS DECORATIVAS  
DECORATIVE COOKER HOODS

# CAMPANAS DECORATIVAS DE PARED

# DECORATIVE COOKER HOODS WALL



**P-221**  
p.40



**P-227**  
p.41



**P-300**  
**P-330**  
p.42



**New Collection**  
**P-401**  
p.44



**P-417**  
p.46



**P-725**  
p.48



**P-730**  
p.50



**P-732**  
p.52



**P-745**  
p.54



**New Collection**  
**P-746**  
p.58



**New Collection**  
**P-823N**  
p.60



**New Collection**  
**P-825**  
p.62



**P-826**  
p.64



**P-827**  
p.66



**P-842/6**  
**P-842/11**  
p.68



**New Collection**  
**P-861**  
p.70



**P-898**  
p.74



**P-960**  
p.76



**P-1001**  
p.78



**P-2000**  
p.80



**P-2000**  
**Vintage**  
p.82



**P-2010**  
p.84

# CAMPANAS DECORATIVAS DE ISLA

# DECORATIVE COOKER HOODS ISLAND



**I-300**  
p.90



**I-330**  
p.90



**I-402**  
p.92



**I-825**  
p.94



**I-826**  
p.96



**New**  
Collection

**I-861**  
p.98



**New**  
Collection

**I-875**  
p.100



**I-897**  
**Cristal**  
**Glass**  
p.102



**I-898**  
p.104



**I-960**  
p.108



**I-1001**  
p.110



**I-1300**  
p.112



**SKY**  
**LOOP**  
p.114



**SKY**  
**LIGHT**  
p.114



# CAMPANAS DECORATIVAS DE TECHO

# DECORATIVE COOKER HOODS

## CEILING



**New**  
Collection

**E-201**  
p.120

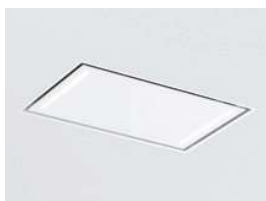

**E-217**  
p.122



**New**  
Collection

**E-219**  
p.124



**E-221**  
p.126



**E-231**  
**E-232**  
p.128



**E-237**  
p.132



**E-240**  
p.136



**E-245**  
p.138



**E-245**  
p.138



**E-245**  
p.138



**New**  
Collection

**E-250**  
p.140



**New**  
Collection

**E-252**  
p.144



**New**  
Collection

**E-265**  
p.146



**New**  
Collection

**E-295**  
p.148



**E-297**  
p.150



**SKY**  
**RING**  
p.154

# CAMPANAS DECORATIVAS DE INTEGRACIÓN / DECORATIVE COOKER HOODS

## INTEGRACIÓN / INTEGRATION



**E-390**  
**E-391**  
p.158



**New Collection**  
**E-392**  
**E-393**  
p.162



**E-320**  
p.166



**New Collection**  
**E-350**  
p.168



**EVO**  
p.173



**PRO**  
p.174



**NCR**  
p.176



**New Collection**  
**GTI**  
p.178



**GRV**  
p.180



**NEO**  
p.181



**TIB**  
p.182



**TIM**  
p.183



**TIM-2**  
p.184



**New Collection**  
**TIX**  
p.186



**BGF SEC System**  
p.188



**PGF**  
p.189



**GIM**  
p.190



**GIT**  
p.192



**ES**  
p.193



**IES SEC System**  
p.194



**IES SEC System Touch**  
p.195



**GR20**  
p.196



**GR05**  
p.196

# CAMPANAS DE PARED

## WALL COOKER HOODS









Model. 90 cm

# P-221

Inox  
Stainless Steel



Modelos / Models

### S.E.C. System® Motor Interior / Interior Motor

Front. (cm)	Motor	Ø tubo	Clas. Ener.	Ref.	P.V.R
60	V.730 ECS	Ø120	A	010081	395 €
70	V.730 ECS	Ø120	A	010082	415 €
90	V.730 ECS	Ø120	A	010083	435 €

Opcionales / Options

Embellecedor a techo. Ref. 7118. (indicar modelo y medida de la campana) Ceiling trim. Ref. 7118. (Specify reference)	120 €
Kits de recirculación. Ver página 210 Activated carbon filters kit. See page 210	
Juego de tubos hasta altura total de 1500 mm Set of chimneys to a total height of 1500 mm (Indicar la medida en su pedido) - (Indicate the size in your order)	180 €
Juego de tubos hasta altura total de entre 1501 y 2000 mm Set of chimneys to a total height of between 1501 and 2000 mm (Indicar la medida en su pedido) - (Indicate the size in your order)	220 €

Notas / Notes

Modelo apto sólo para encimeras compactas de 60 o 70 cm de ancho.  
Recommended for hobs up to 60 or 70 cm wide.

Esquemas medidas / Technical Drawings

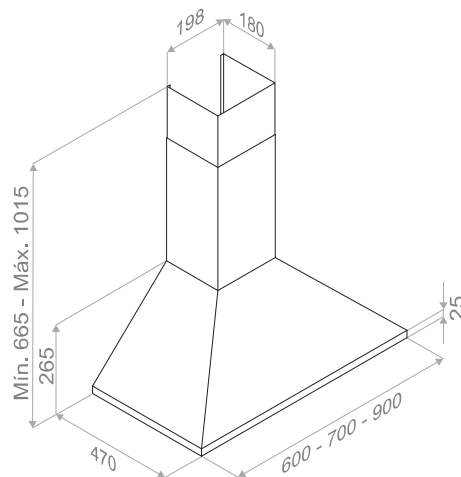

Tubos especiales a medida / Special custom-made chimneys



Acceso / Acces WEB



## P-227 <sup>Inox</sup> Stainless Steel



Modelos / Models

### S.E.C. System®

#### Motor Interior / Interior Motor

Front. (cm)	Motor	Ø tubo	Clas. Ener.	Ref.	P.V.R
60	V.850	Ø150	A	001571	695 €
70	V.850	Ø150	A	001573	745 €
90	V.850	Ø150	A	001576	745 €

Opcionales / Options

### AirLink

Modelo compatible. Es imprescindible solicitar esta opción en el pedido de la campana. No se equipa de serie  
Compatible Model. This option must be requested together with the purchase order. Is not included as standard.

0 €

Embellecedor a techo. Ref. 7118. (indicar modelo y medida de la campana)  
Ceiling trim. Ref. 7118. (Specify reference)

120 €

Kits de recirculación. Ver página 210  
Activated carbon filters kit. See page 210

Mando a distancia Touch. Suministrado con la campana.  
Remote Control Touch supplied together with the hood.

120 €

Juego de tubos hasta altura total de 1500 mm  
Set of chimneys to a total height of 1500 mm  
(Indicar la medida en su pedido) - (Indicate the size in your order)

180 €

Juego de tubos hasta altura total de entre 1501 y 2000 mm  
Set of chimneys to a total height of between 1501 and 2000 mm  
(Indicar la medida en su pedido) - (Indicate the size in your order)

220 €

Esquemas medidas / Technical Drawings

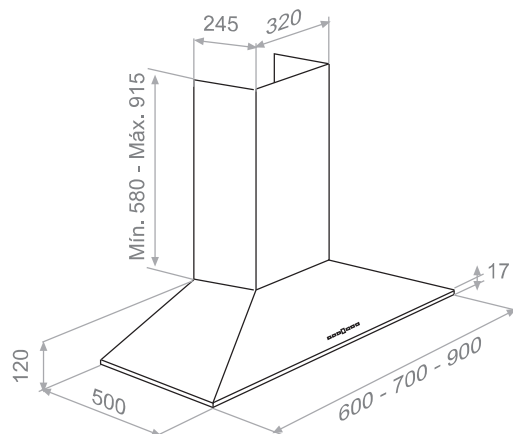

Tubos especiales a medida / Special custom-made chimneys



Acceso / Acces WEB



**P-300** Inox  
Stainless Steel

**P-330** Cristal - Touch Control  
Glass - Touch control

**Fabricadas a medida.  
Custom Made.**

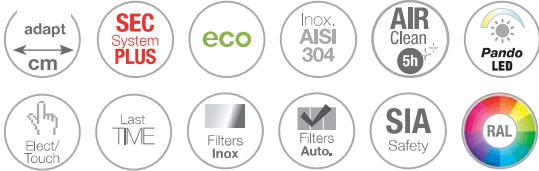

Modelos / Models

**S.E.C. System®**

**Motor Interior / Interior Motor**

Motor	Ø tubo
V.750	Ø125
V.850	Ø150
V.1050 eco SEC® PLUS	Ø150
V.1250 eco	Ø150
V.2200 eco	Ø200

**Motor Intermedio exterior / Duct-in-line motor**

V.1550 eco	Ø150
V.2450 eco	Ø200
V.3000 eco	Ø200

**Motor Exterio a muro / Remote motor - Wall Outdoor**

V.1300	Ø150
--------	------

**Motor de tejado / Remote motor -Roof Outdoor**

V.2350 eco	Ø200
V.3300 eco	Ø200

Opcionales / Options

**AirLink**

Solicitar esta opción en el pedido de la campana. No se equipa de serie  
Requested This option in the purchase order. Is not included as standard. 0 €

Kits de recirculación. Bajo presupuesto  
Activated carbon filters kit. On request

Mando a distancia Touch. Suministrado con la campana.  
Remote Control Touch supplied together with the hood. 120 €

Notas / Notes

**P-330**

Botonera TOUCH únicamente en acabados blanco o negro brillo.  
TOUCH control only in glossy black or white finish.

Resto de colores, incorporan botonera electrónica + Last Time en zona inferior.  
The rest of the colours incorporate electronic control + Last Time in lower section.

**P-330 - AirClean**

Sistema automático de funcionamiento del motor 10 min. cada hora durante 5 horas.  
Automatic working motor system for 10 minutes every hour during 5 hours.

**Bajo presupuesto / On request**

Modelo personalizable en cualquier color de la carta RAL.  
Customizable model in any color from the RAL chart



Esquemas medidas / Technical Drawings

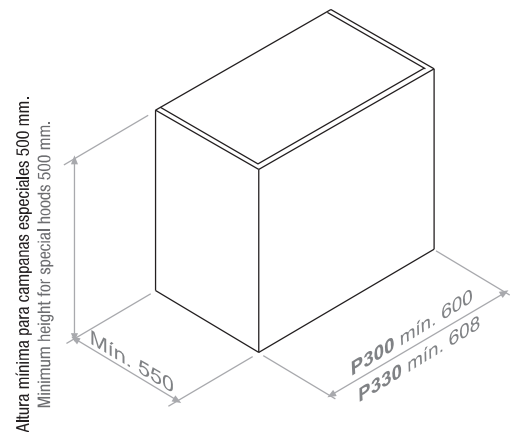

Altura mínima para campanas especiales 500 mm.  
Minimum height for special hoods 500 mm.



Acceso / Acces WEB  
P-300



Acceso / Acces WEB  
P-330

Acceso a esquemas para confirmar las medidas.  
Access to the scheme to confirm hood dimension details.



Pared / Wall



**P-300**  
**P-330**

# P-401

Inox  
Stainless Steel

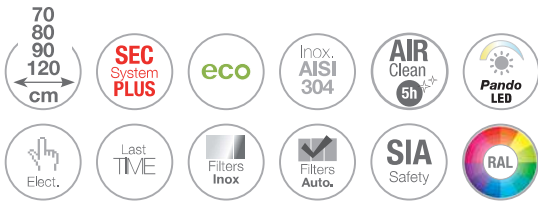

Pared / Wall

Modelos / Models

## S.E.C. System® Motor Interior / Interior Motor

Front. (cm)	Motor	Ø tubo	Clas. Ener.	Ref.	P.V.R
70	V.750	Ø125	B	009750	1.075 €
	V.850	Ø150	A+	009751	1.075 €
	V.1050 eco SEC® PLUS	Ø150	A+	009752	1.295 €
	V.1250 eco	Ø150	A++	009753	1.495 €
	V.750	Ø125	B	008176	1.075 €
80	V.850	Ø150	A+	006865	1.075 €
	V.1050 eco SEC® PLUS	Ø150	A+	009269	1.295 €
	V.1250 eco	Ø150	A++	008177	1.495 €
	V.750	Ø125	B	008180	1.195 €
90	V.850	Ø150	A+	006866	1.195 €
	V.1050 eco SEC® PLUS	Ø150	A+	009275	1.395 €
	V.1250 eco	Ø150	A++	008181	1.595 €
120	V.850	Ø150	A+	006867	1.365 €
	V.1050 eco SEC® PLUS	Ø150	A+	009281	1.595 €
	V.1250 eco	Ø150	A+	008184	1.795 €

## Motor Intermedio exterior / Duct-in-line motor

Front. (cm)	Motor	Ø tubo	Clas. Ener.	Ref.	P.V.R
90	V.1550 eco	Ø150	A+	009276	2.045 €
	V.2450 eco	Ø200	A+	009278	2.495 €
120	V.1550 eco	Ø150	A+	009282	2.195 €
	V.2450 eco	Ø200	A+	009284	2.595 €

## Motor de tejado / Remote motor: Roof Outdoor

Front. (cm)	Motor	Ø tubo	Clas. Ener.	Ref.	P.V.R
90	V.2350 eco	Ø200	A+	009279	2.595 €
120	V.2350 eco	Ø200	A+	009285	2.695 €

Opcionales / Options

<b>AirLink</b> Solicitar esta opción en el pedido de la campana. No se equipa de serie Requested This option in the purchase order. Is not included as standard.	0 €
Embellecedor a techo. Ref. 7118. (indicar modelo y medida de la campana) Ceiling trim. Ref. 7118. (Specify reference)	120 €
Kits de recirculación. Ver página 210 Activated carbon filters kit. See page 210	
Mando a distancia Touch. Suministrado con la campana. Remote Control Touch supplied together with the hood.	120 €
Juego de tubos hasta altura total de 1500 mm Set of chimneys to a total height of 1500 mm (Indicar la medida en su pedido) - (Indicate the size in your order)	180 €
Juego de tubos hasta altura total de entre 1501 y 2000 mm Set of chimneys to a total height of between 1501 and 2000 mm (Indicar la medida en su pedido) - (Indicate the size in your order)	220 €

Notas / Notes

Para modelos con carbón activado las medidas de los tubos serán:  
The flues will be as follows for models with activated carbon:  
Mín. 645 - Máx. 1045

### AirClean

Sistema automático de funcionamiento del motor 10 min. cada hora durante 5 horas.  
Automatic working motor system for 10 minutes every hour during 5 hours.

### Bajo presupuesto / On request

Modelo personalizable en cualquier color de la carta RAL  
Customizable model in any color from the RAL chart

Esquemas medidas / Technical Drawings

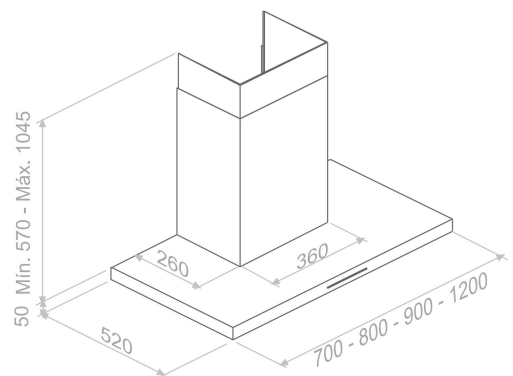

Tubos especiales a medida / Special custom-made chimneys



Acceso / Acces WEB



Model. 90 cm

Pared / Wall



**P-401**



# P-417 Inox Stainless Steel

Retroiluminado con led  
LED backlit



Modelos / Models

## S.E.C. System® Motor Interior / Interior Motor

Front. (cm)	Motor	Ø tubo	Clas. Ener.	Ref.	P.V.R
90	V.750	Ø125	B	009203	990 €
	V.850	Ø150	A	009204	990 €
	V.1050 eco SEC® PLUS	Ø150	A+	009290	1.245 €
	V.1250 eco	Ø150	A++	009291	1.495 €

Pared / Wall



Opcionales / Options

### AirLink

Solicitar esta opción en el pedido de la campana. No se equipa de serie  
Requested This option in the purchase order. Is not included as standard.

0 €

Opción de cambio de LED original a LED de luz cálida de 3000K.  
Suministrado con la campana.

80 €

LED change to warm light LED 3000K. Available only at the factory

Kits de recirculación. Ver página 210

Activated carbon filters kit. See page 210

Mando a distancia Touch. Suministrado con la campana.

Remote Control Touch supplied together with the hood.

120 €

Juego de tubos hasta altura total de 1500 mm

Set of chimneys to a total height of 1500 mm

(Indicar la medida en su pedido) - (Indicate the size in your order)

180 €

Juego de tubos hasta altura total de entre 1501 y 2000 mm

Set of chimneys to a total height of between 1501 and 2000 mm

(Indicar la medida en su pedido) - (Indicate the size in your order)

220 €

Notas / Notes

Este modelo solo se suministra en acabado INOX  
This model is only supplied in INOX finish

Esquemas medidas / Technical Drawings

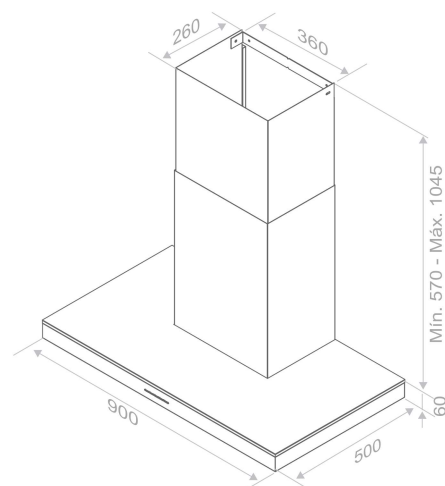

Tubos especiales a medida / Special custom-made chimneys



Acceso / Acces WEB



Pared / Wall



**P-417**



# P-725 Inox Stainless Steel

**Cristal blanco o negro**  
**Black or white glass**

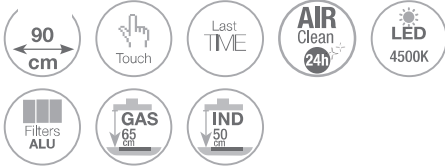

Modelos / Models

## S.E.C. System® Motor Interior / Interior Motor

Front. (cm)	Motor	Ø tubo	Clas. Ener.	Ref.	P.V.R
<b>Negro / Black</b>					
90	V.850	Ø150	A	010049	650 €
<b>Blanco / White</b>					
90	V.850	Ø150	A	010048	675 €

Opcionales / Options

Embellecedor a techo. Ref. 7118. (indicar modelo y medida de la campana) Ceiling trim. Ref. 7118. (Specify reference)	120 €
Cambio a LED cálido de 3000K. Suministrado con la campana. LED change to warm light LED 3000K. Available only at the factory	80 €
Kits de recirculación. Ver página 210 Activated carbon filters kit. See page 210	
Juego de tubos hasta altura total de 1500 mm Set of chimneys to a total height of 1500 mm (Indicar la medida en su pedido) - (Indicate the size in your order)	180 €
Juego de tubos hasta altura total de entre 1501 y 2000 mm Set of chimneys to a total height of between 1501 and 2000 mm (Indicar la medida en su pedido) - (Indicate the size in your order)	220 €
Pintado Juegos de tubos en BLANCO o NEGRO Painted Tube sets in WHITE or BLACK	100 €

Notas / Notes

- Altura recomendada de instalación desde la zona de cocción a la base de la campana 50 cm.  
Para encimeras de gas altura mínima 65 cm.  
The recommended distance between the base of the hood and cooking area is 50 cm. The minimum distance between the base of the hood and a gas hob is 65 cm.
- Recomendada en zonas de cocción compacta de hasta 60 cm.  
Recommended for hobs up to 60 cm.
- Para un funcionamiento en alto rendimiento es recomendable mantener la puerta de acceso a los filtros abierta.  
The filter access door should be kept open for an optimal performance.
- Este modelo no tiene posibilidad de salida de humos trasera.  
This model does not offer a rear exit option.
- AirClean**  
Sistema automático de funcionamiento del motor 10 min. cada hora durante 24 horas.  
Automatic working motor system for 10 minutes every hour during 24 hours.
- Modelo con doble filtraje.  
Model with double filtering

Esquemas medidas / Technical Drawings

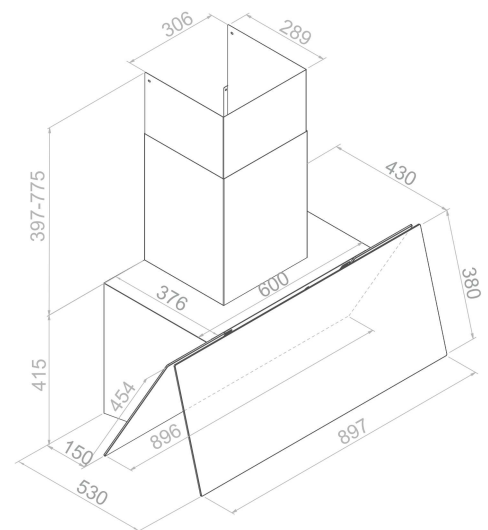

Acceso / Acces WEB





Pared / Wall



**P-725**



# P-730

Inox - Cristal negro / blanco  
Stainless Steel - Black / white glass

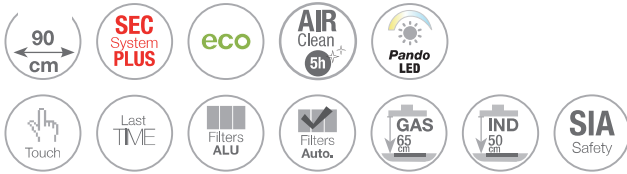

## Modelos / Models

### S.E.C. System®

#### Motor Interior / Interior Motor

Front. (cm)	Motor	Ø tubo	Clas. Ener.	Ref.	P.V.R
<b>Negro / Black</b>					
90	V.850	Ø150	A+	009221	1.045 €
	V.1050 eco SEC® PLUS	Ø150	A+	010052	1.345 €
<b>Blanco / White</b>					
90	V.850	Ø150	A+	009220	1.045 €
	V.1050 eco SEC® PLUS	Ø150	A+	010051	1.345 €
<b>Cuerpo negro y puerta blanca / Black glass and white central panel</b>					
90	V.850	Ø150	A+	009217	1.045 €
	V.1050 eco SEC® PLUS	Ø150	A+	010050	1.345 €
<b>Cuerpo blanco y puerta negra / White glass and black central panel</b>					
90	V.850	Ø150	A+	009677	1.045 €
	V.1050 eco SEC® PLUS	Ø150	A+	010053	1.345 €

## Opcionales / Options

Embellecedor a techo. Ref. 7118. (indicar modelo y medida de la campana) Ceiling trim. Ref. 7118. (Specify reference)	120 €
Kits de recirculación. Ver página 210 Activated carbon filters kit. See page 210	
Opción salida trasera de serie (ver manual de instalación) Option of rear exit (Please, consult the Installation Guide)	
Juego de tubos hasta altura total de 1500 mm Set of chimneys to a total height of 1500 mm (Indicar la medida en su pedido) - (Indicate the size in your order)	180 €
Juego de tubos hasta altura total de entre 1501 y 2000 mm Set of chimneys to a total height of between 1501 and 2000 mm (Indicar la medida en su pedido) - (Indicate the size in your order)	220 €
Pintado Juegos de tubos en BLANCO o NEGRO Painted Tube sets in WHITE or BLACK	100 €

## Notas / Notes

- Altura recomendada de instalación desde la zona de cocción a la base de la campana 50 cm.  
Para encimeras de gas altura mínima 65 cm.  
The recommended distance between the base of the hood and cooking area is 50 cm.  
The minimum distance between the base of the hood and a gas hob is 65 cm.
- Recomendada en zonas de cocción compacta de hasta 60 cm.  
Recommended for hobs up to 60 cm.
- Panel frontal con apertura fija suspendida  
Front Panel with suspended fixed opening.
- Para un funcionamiento en alto rendimiento es recomendable mantener la puerta de acceso a los filtros abierta.  
The filter access door should be kept open for an optimal performance.
- AirClean**  
Sistema automático de funcionamiento del motor 10 min. cada hora durante 5 horas.  
Automatic working motor system for 10 minutes every hour during 5 hours.

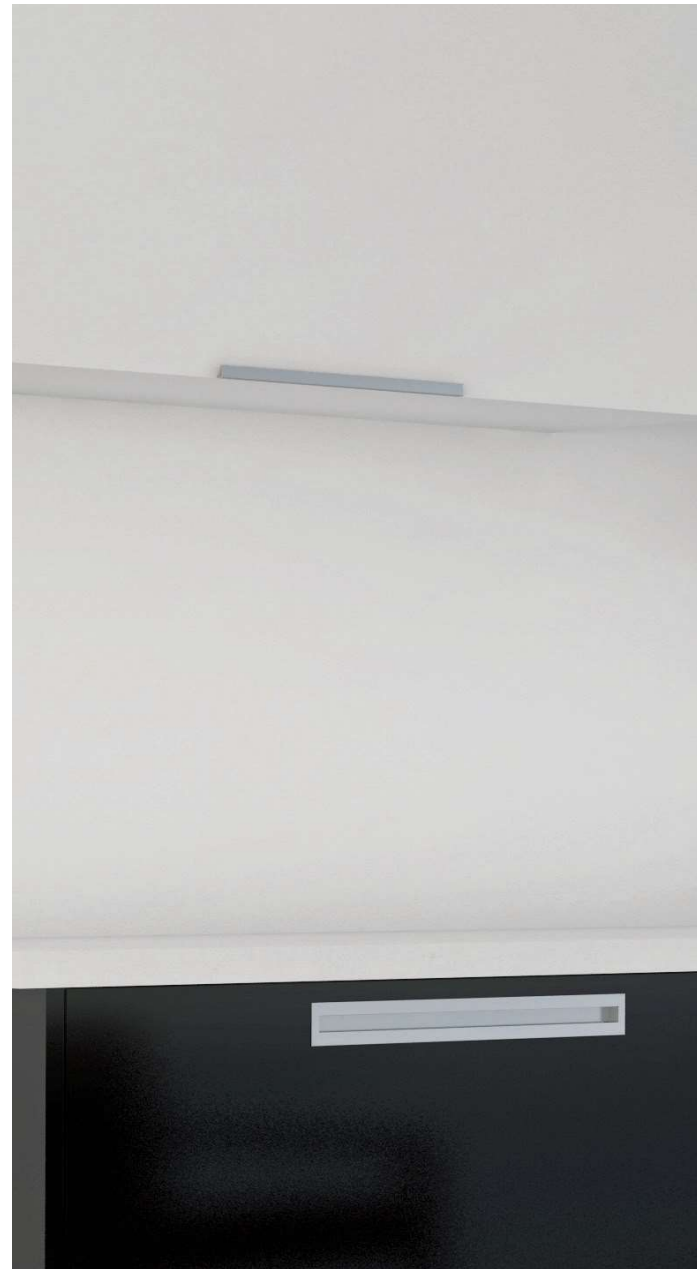

## Esquemas medidas / Technical Drawings

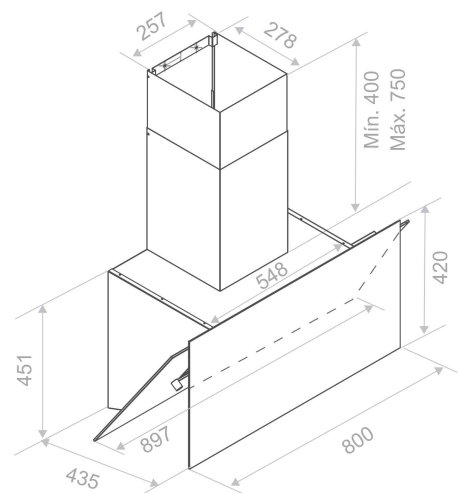

■ Tubos especiales a medida / Special custom-made chimneys



Acceso / Acces WEB



Pared / Wall



**P-730**

# P-732

Inox - Cristal negro o blanco  
Stainless Steel - Black or White glass

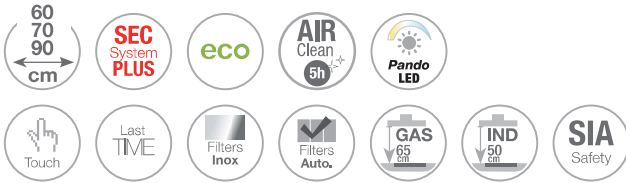

Modelos / Models

## S.E.C. System® Motor Interior / Interior Motor

Front. (cm)	Motor	Ø tubo	Clas. Ener.	Ref.	P.V.R
<b>Negro / Black</b>					
60	V.750	Ø125	B	008852	1.095 €
	V.850	Ø150	A+	008629	1.095 €
	V.1050 eco SEC® PLUS	Ø150	A+	010056	1.345 €
70	V.750	Ø125	B	008853	1.145 €
	V.850	Ø150	A+	008630	1.145 €
	V.1050 eco SEC® PLUS	Ø150	A+	010057	1.395 €
90	V.750	Ø125	B	008854	1.145 €
	V.850	Ø150	A+	008631	1.145 €
	V.1050 eco SEC® PLUS	Ø150	A+	010058	1.395 €
<b>Blanco / White</b>					
60	V.750	Ø125	B	008855	1.145 €
	V.850	Ø150	A+	008632	1.145 €
	V.1050 eco SEC® PLUS	Ø150	A+	010059	1.395 €
70	V.750	Ø125	B	008856	1.195 €
	V.850	Ø150	A+	008633	1.195 €
	V.1050 eco SEC® PLUS	Ø150	A+	010060	1.445 €
90	V.750	Ø125	B	008857	1.195 €
	V.850	Ø150	A+	008634	1.195 €
	V.1050 eco SEC® PLUS	Ø150	A+	010061	1.445 €

Opcionales / Options

### AirLink

Modelo compatible. Es imprescindible solicitar esta opción en el pedido de la campana. No se equipa de serie  
Compatible Model. This option must be requested together with the purchase order. Is not included as standard.

Embellecedor a techo. Ref. 7118. (indicar modelo y medida de la campana)  
Ceiling trim. Ref. 7118. (Specify reference)

Kits de recirculación. Ver página 210  
Activated carbon filters kit. See page 210

Opción salida trasera de serie. Indicar en pedido.  
Option of rear exit, has to be mentioned in the order.

Juego de tubos hasta altura total de 1500 mm  
Set of chimneys to a total height of 1500 mm  
(Indicar la medida en su pedido) - (Indicate the size in your order)

Juego de tubos hasta altura total de entre 1501 y 2000 mm  
Set of chimneys to a total height of between 1501 and 2000 mm  
(Indicar la medida en su pedido) - (Indicate the size in your order)

Pintado Juegos de tubos en BLANCO o NEGRO  
Painted Tube sets in WHITE or BLACK

Notas / Notes

Altura recomendada de instalación desde la zona de cocción a la base de la campana 50 cm.

Para encimeras de gas altura mínima 65 cm.  
The recommended distance between the base of the hood and cooking area is 50 cm.  
The minimum distance between the base of the hood and a gas hob is 65 cm.

Recomendada en zonas de cocción compacta de hasta 60 cm.  
Recommended for hobs up to 60 cm.

Para un funcionamiento en alto rendimiento es recomendable mantener la puerta de acceso a los filtros abierta.  
The filter access door should be kept open for an optimal performance.

### AirClean

Sistema automático de funcionamiento del motor 10 min. cada hora durante 5 horas.  
Automatic working motor system for 10 minutes every hour during 5 hours.

Esquemas medidas / Technical Drawings

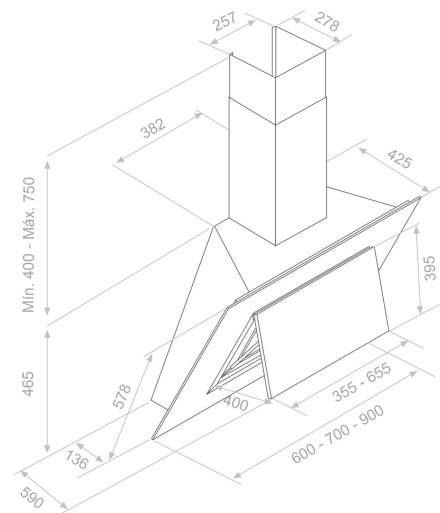

Tubos especiales a medida / Special custom-made chimneys



Acceso / Acces WEB





Pared / Wall



**P-732**



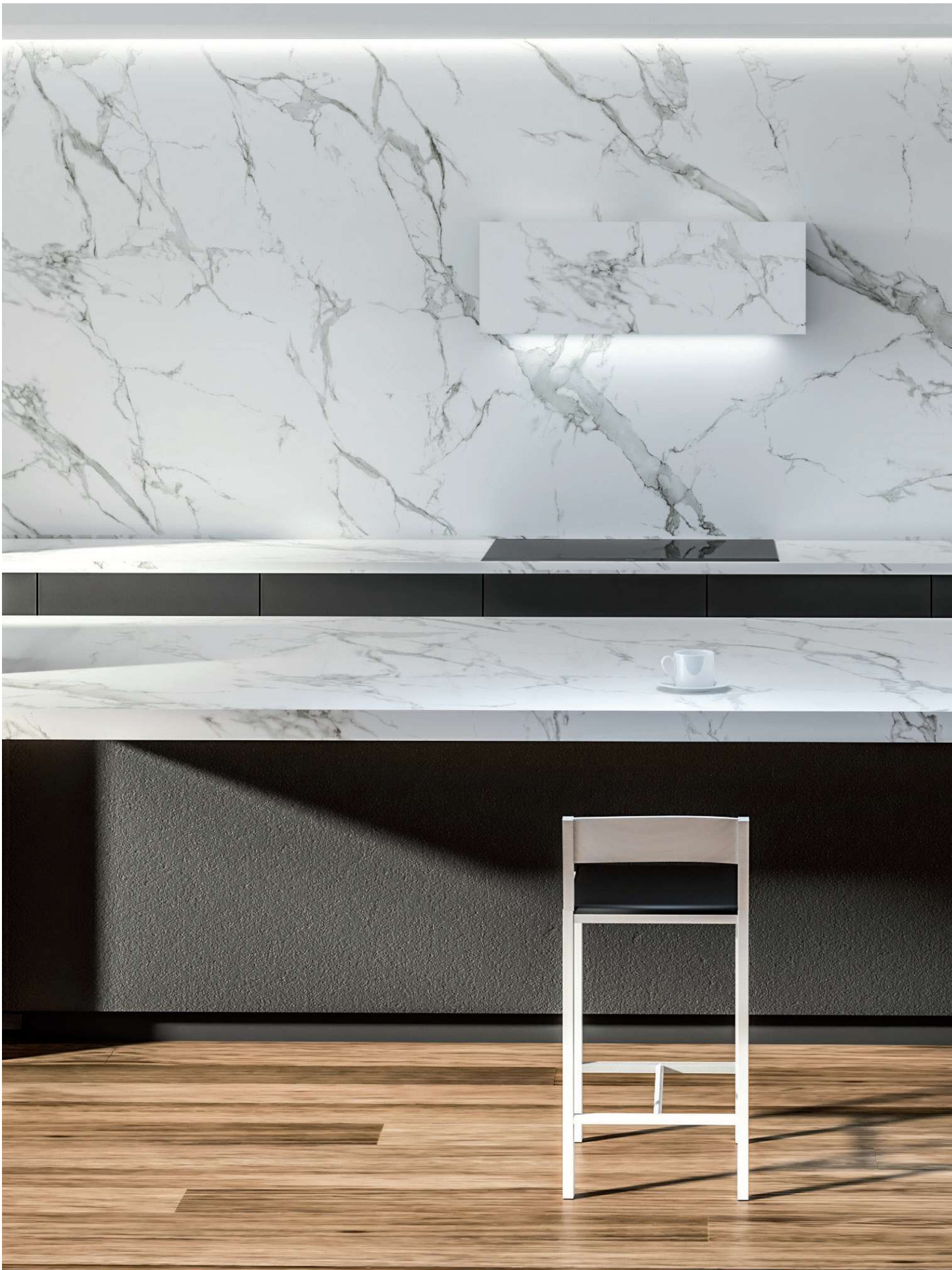



**P-745**



# P-745 Inox - DEKTON®



Modelos / Models

## S.E.C. System® Motor Interior / Interior Motor

Front. (cm)	Motor	Ø tubo	Clas. Ener.	Ref.	P.V.R
<b>DEKTON® SIRIUS</b>					
90	V.850	Ø150	A	009940	1.245 €
	V.1050 eco SEC® PLUS	Ø150	A	009941	1.395 €
<b>DEKTON® ZENITH</b>					
90	V.850	Ø150	A	009936	1.245 €
	V.1050 eco SEC® PLUS	Ø150	A	009937	1.395 €
<b>DEKTON® AURA15</b>					
90	V.850	Ø150	A	009938	1.245 €
	V.1050 eco SEC® PLUS	Ø150	A	009939	1.395 €



Pared / Wall

Opcionales / Options

### AirLink

Modelo compatible. Es imprescindible solicitar esta opción en el pedido de la campana. No se equipa de serie. 0 €  
Compatible Model. This option must be requested together with the purchase order. Is not included as standard.

Embellecedor a techo. Ref. 7118. (indicar modelo y medida de la campana) 120 €  
Ceiling trim. Ref. 7118. (Specify reference)

Opción salida trasera de serie. Indicar en pedido. 120 €  
Option of rear exit, has to be mentioned in the order.

Kits de recirculación. Ver página 210  
Activated carbon filters kit. See page 210

Mando a distancia Touch. Suministrado con la campana. 120 €  
Remote Control Touch supplied together with the hood.

Juego de tubos hasta altura total de 1500 mm 180 €  
Set of chimneys to a total height of 1500 mm  
(Indicar la medida en su pedido) - (Indicate the size in your order)

Juego de tubos hasta altura total de entre 1501 y 2000 mm 220 €  
Set of chimneys to a total height of between 1501 and 2000 mm  
(Indicar la medida en su pedido) - (Indicate the size in your order)

Notas / Notes

El material DEKTON® tiene un grosor de 8 mm  
DEKTON® material is 8 mm thick

### AirClean

Sistema automático de funcionamiento del motor 10 min. cada hora durante 5 horas.  
Automatic working motor system for 10 minutes every hour during 5 hours.

Esquemas medidas / Technical Drawings

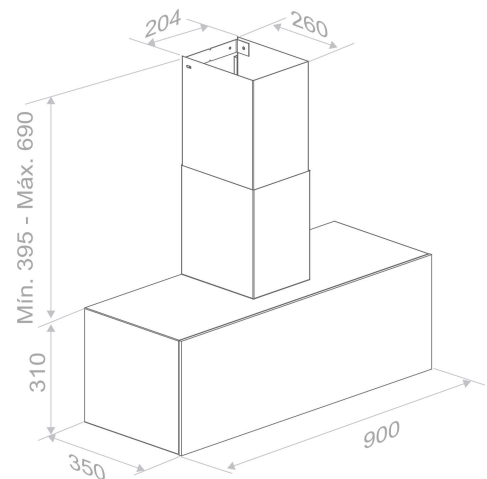

■ Tubos especiales a medida / Special custom-made chimneys



Acceso / Acces WEB

DEKTON® ZENITH



Pared / Wall

DEKTON® AURA 15



**P-745**



# P-746

Inox - DEKTON®



Pared / Wall

Modelos / Models

## S.E.C. System® Motor Interior / Interior Motor

Front. (cm)	Motor	Ø tubo	Clas. Ener.	Ref.	P.V.R
<b>DEKTON® LAURENT</b>					
90	V.850	Ø150	A	010245	1.525 €
	V.1050 eco SEC® PLUS	Ø150	A+	010246	1.725 €
120	V.850	Ø150	A	010443	1.795 €
	V.1050 eco SEC® PLUS	Ø150	A+	010444	1.995 €
<b>DEKTON® AERIS</b>					
90	V.850	Ø150	A	010247	1.450 €
	V.1050 eco SEC® PLUS	Ø150	A+	010248	1.650 €
120	V.850	Ø150	A	010445	1.750 €
	V.1050 eco SEC® PLUS	Ø150	A+	010446	1.950 €
<b>DEKTON® KELYA</b>					
90	V.850	Ø150	A	010249	1.490 €
	V.1050 eco SEC® PLUS	Ø150	A+	010250	1.690 €
120	V.850	Ø150	A	010447	1.790 €
	V.1050 eco SEC® PLUS	Ø150	A+	010448	1.990 €
<b>DEKTON® TRILIUM</b>					
90	V.850	Ø150	A	010251	1.490 €
	V.1050 eco SEC® PLUS	Ø150	A+	010252	1.690 €
120	V.850	Ø150	A	010449	1.790 €
	V.1050 eco SEC® PLUS	Ø150	A+	010450	1.990 €
<b>DEKTON® ZENITH</b>					
90	V.850	Ø150	A	010253	1.490 €
	V.1050 eco SEC® PLUS	Ø150	A+	010254	1.690 €
120	V.850	Ø150	A	010451	1.790 €
	V.1050 eco SEC® PLUS	Ø150	A+	010452	1.990 €

## RECIRCULACIÓN / RECIRCULATION FCLR-AE S.E.C. System® Motor Interior / Interior Motor

Front. (cm)	Motor	Ø tubo	Clas. Ener.	Ref.	P.V.R
<b>DEKTON® LAURENT</b>					
90	V.850	Ø150	A	010301	1.680 €
	V.1050 eco SEC® PLUS	Ø150	A+	010302	1.790 €
120	V.850	Ø150	A	010453	1.980 €
	V.1050 eco SEC® PLUS	Ø150	A+	010454	2.090 €
<b>DEKTON® AERIS</b>					
90	V.850	Ø150	A	010303	1.615 €
	V.1050 eco SEC® PLUS	Ø150	A+	010304	1.725 €
120	V.850	Ø150	A	010455	1.915 €
	V.1050 eco SEC® PLUS	Ø150	A+	010456	2.025 €
<b>DEKTON® KELYA</b>					
90	V.850	Ø150	A	010305	1.660 €
	V.1050 eco SEC® PLUS	Ø150	A+	010306	1.770 €
120	V.850	Ø150	A	010457	1.960 €
	V.1050 eco SEC® PLUS	Ø150	A+	010458	2.070 €
<b>DEKTON® TRILIUM</b>					
90	V.850	Ø150	A	010307	1.660 €
	V.1050 eco SEC® PLUS	Ø150	A+	010308	1.770 €
120	V.850	Ø150	A	010459	1.960 €
	V.1050 eco SEC® PLUS	Ø150	A+	010460	2.070 €
<b>DEKTON® ZENITH</b>					
90	V.850	Ø150	A	010309	1.655 €
	V.1050 eco SEC® PLUS	Ø150	A+	010310	1.660 €
120	V.850	Ø150	A	010461	1.955 €
	V.1050 eco SEC® PLUS	Ø150	A+	010462	1.960 €

**Este modelo incorpora tubos de salida de humos**  
This model incorporates chimney

**Este modelo NO incorpora tubos de salida de humos**  
This model does NOT incorporate chimney

Opcionales / Options

### AirLink

Modelo compatible. Es imprescindible solicitar esta opción en el pedido de la campana. No se equipa de serie. 0 €  
Compatible Model. This option must be requested together with the purchase order. Is not included as standard.

Embellecedor a techo. Ref. 7118. (indicar modelo y medida de la campana) 120 €  
Ceiling trim. Ref. 7118. (Specify reference)

Opción salida trasera de serie. Indicar en pedido. 120 €  
Option of rear exit, has to be mentioned in the order.

Kits de recirculación. Ver página 210  
Activated carbon filters kit. See page 210

Mando a distancia Touch. Suministrado con la campana. 120 €  
Remote Control Touch supplied together with the hood.

Juego de tubos hasta altura total de 1500 mm 180 €  
Set of chimneys to a total height of 1500 mm  
(Indicar la medida en su pedido) - (Indicate the size in your order)

Juego de tubos hasta altura total de entre 1501 y 2000 mm 220 €  
Set of chimneys to a total height of between 1501 and 2000 mm  
(Indicar la medida en su pedido) - (Indicate the size in your order)

Notas / Notes

El material DEKTON® tiene un grosor de 4 mm  
DEKTON® material is 4 mm thick

### AirClean

Sistema automático de funcionamiento del motor 10 min. cada hora durante 5 horas.  
Automatic working motor system for 10 minutes every hour during 5 hours.

Esquemas medidas / Technical Drawings

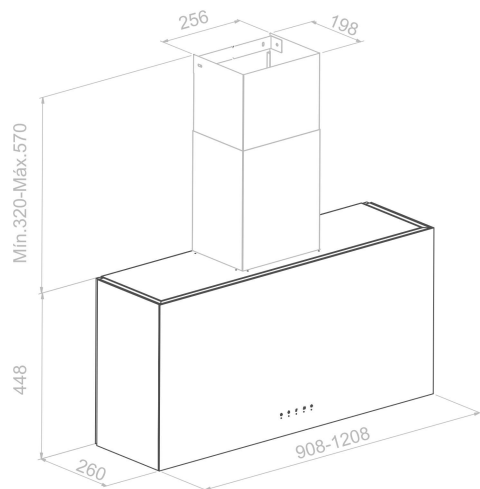

**Tubos especiales a medida / Special custom-made chimneys**  
Tubo salida de humos opcional / Optional chimney



Acceso / Acces WEB

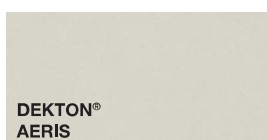

DEKTON®  
AERIS



DEKTON®  
KELIA



DEKTON®  
LAURENT



DEKTON®  
TRILUM



DEKTON®  
ZENIT

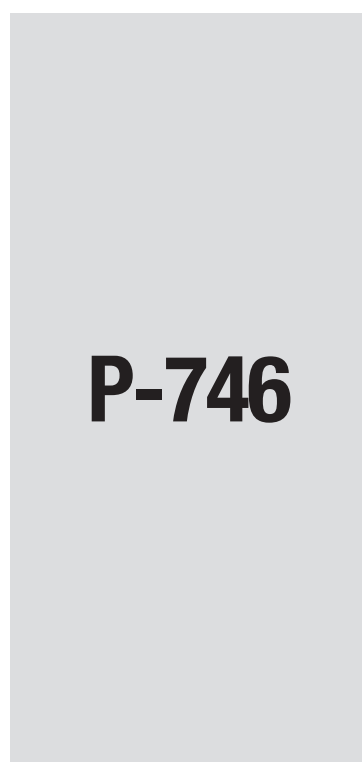

**P-746**

# P-823N

Inox  
Stainless Steel



Pared / Wall

Modelos / Models

### S.E.C. System® Motor Interior / Interior Motor

Front. (cm)	Motor	Ø tubo	Clas. Ener.	Ref.	P.V.R
60	V.850	Ø150	A	010255	455 €
70	V.850	Ø150	A	010256	505 €
90	V.850	Ø150	A	010257	525 €

Opcionales / Options

Embellecedor a techo. Ref. 7118. (indicar modelo y medida de la campana) Ceiling trim. Ref. 7118. (Specify reference)	120 €
Kits de recirculación. Ver página 210 Activated carbon filters kit. See page 210	
Filtro inoxidable. Precio unitario Stainless steel filter. Unit price	39 €
Juego de tubos hasta altura total de 1500 mm Set of chimneys to a total height of 1500 mm (Indicar la medida en su pedido) - (Indicate the size in your order)	180 €
Juego de tubos hasta altura total de entre 1501 y 2000 mm Set of chimneys to a total height of between 1501 and 2000 mm (Indicar la medida en su pedido) - (Indicate the size in your order)	220 €
Cambio a LED cálido de 3000K. Suministrado con la campana LED change to warm light LED 3000K. Available only at the factory	80 €

Notas / Notes

**AirClean**  
Sistema automático de funcionamiento del motor 10 min. cada hora durante 5 horas.  
Automatic working motor system for 10 minutes every hour during 5 hours.

Esquemas medidas / Technical Drawings

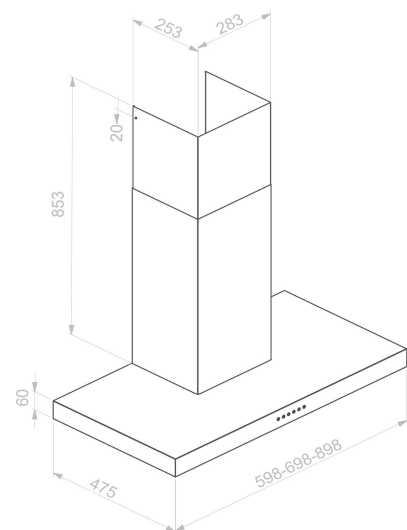

■ Tubos especiales a medida / Special custom-made chimneys



Acceso / Acces WEB





Model. 90 cm

Pared / Wall



**P-823N**



# P-825

Inox, Blanco o Negro Satinado RAL 9005  
Stainless Steel, White or Satin Black RAL 9005

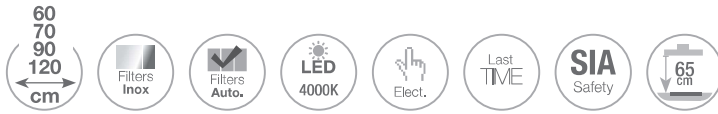

Pared / Wall

Modelos / Models

## S.E.C. System® Motor Interior / Interior Motor

Front. (cm)	Motor	Ø tubo	Clas. Ener.	Ref.	P.V.R
<b>Inox / Stainless Steel</b>					
60	V.750	Ø125	B	010266	660 €
	V.850	Ø150	A+	010267	660 €
	V.1050 eco SEC® PLUS	Ø150	A+	010268	995 €
70	V.750	Ø125	B	008976	660 €
	V.850	Ø150	A+	008977	660 €
	V.1050 eco SEC® PLUS	Ø150	A+	010275	995 €
90	V.750	Ø125	B	008875	695 €
	V.850	Ø150	A+	007313	695 €
	V.1050 eco SEC® PLUS	Ø150	A+	010281	995 €
	V.1250 eco	Ø150	A++	010282	1.195 €
120	V.850	Ø150	A+	010288	995 €
	V.1050 eco SEC® PLUS	Ø150	A+	010289	1.285 €
	V.1250 eco	Ø150	A+	010290	1.485 €
<b>Blanco / White</b>					
60	V.750	Ø125	B	010269	699 €
	V.850	Ø150	A+	010270	699 €
	V.1050 eco SEC® PLUS	Ø150	A+	010271	995 €
70	V.750	Ø125	B	008968	699 €
	V.850	Ø150	A+	008969	699 €
	V.1050 eco SEC® PLUS	Ø150	A+	010277	995 €
90	V.750	Ø125	B	008970	699 €
	V.850	Ø150	A+	008971	699 €
	V.1050 eco SEC® PLUS	Ø150	A+	010283	995 €
	V.1250 eco	Ø150	A++	010284	1.195 €
120	V.850	Ø150	A+	010292	1.095 €
	V.1050 eco SEC® PLUS	Ø150	A+	010293	1.385 €
	V.1250 eco	Ø150	A+	010294	1.585 €
<b>Negro Satinado / Satin black</b>					
60	V.750	Ø125	B	010272	699 €
	V.850	Ø150	A+	010273	699 €
	V.1050 eco SEC® PLUS	Ø150	A+	010274	995 €
70	V.750	Ø125	B	010107	699 €
	V.850	Ø150	A+	010108	699 €
	V.1050 eco SEC® PLUS	Ø150	A+	010279	995 €
90	V.750	Ø125	B	010109	735 €
	V.850	Ø150	A+	010110	735 €
	V.1050 eco SEC® PLUS	Ø150	A+	010285	1.045 €
	V.1250 eco	Ø150	A++	010286	1.245 €
120	V.850	Ø150	A+	010296	1.095 €
	V.1050 eco SEC® PLUS	Ø150	A+	010297	1.385 €
	V.1250 eco	Ø150	A+	010298	1.585 €

Opcionales / Options

## AirLink

Modelo compatible. Es imprescindible solicitar esta opción en el pedido de la campana. No se equipa de serie  
Compatible Model. This option must be requested together with the purchase order. Is not included as standard.

0 €

Embellecedor a techo. Ref. 7118. (indicar modelo y medida de la campana)  
Ceiling trim. Ref. 7118. (Specify reference)

120 €

Kits de recirculación. Ver página 210  
Activated carbon filters kit. See page 210

Substitución del LED original por el sistema Pando LED  
Change of the original LED to the Pando LED system

80 €

Mando a distancia Touch. Suministrado con la campana.  
Remote Control Touch supplied together with the hood.

120 €

Juego de tubos INOX hasta altura total de 1500 mm  
Stainless steel chimney set to a total height of 1500 mm  
(Indicar la medida en su pedido) - (Indicate the size in your order)

180 €

Juego de tubos INOX hasta altura total de entre 1501 y 2000 mm  
Stainless steel chimney set to a total height of between 1501 and 2000 mm  
(Indicar la medida en su pedido) - (Indicate the size in your order)

220 €

Juego de tubos BLANCO hasta altura total de 1500 mm  
WHITE chimney set to a total height of 1500 mm  
(Indicar la medida en su pedido) - (Indicate the size in your order)

290 €

Juego de tubos BLANCO hasta altura total de entre 1501 y 2000 mm  
WHITE chimney set to a total height of between 1501 and 2000 mm  
(Indicar la medida en su pedido) - (Indicate the size in your order)

375 €

Juego de tubos NEGRO SATINADO hasta altura total de 1500 mm  
BLACK chimney set to a total height of 1500 mm  
(Indicar la medida en su pedido) - (Indicate the size in your order)

290 €

Juego de tubos NEGRO SATINADO hasta altura total de entre 1501 y 2000 mm  
BLACK chimney set to a total height of between 1501 and 2000 mm  
(Indicar la medida en su pedido) - (Indicate the size in your order)

375 €

Esquemas medidas / Technical Drawings

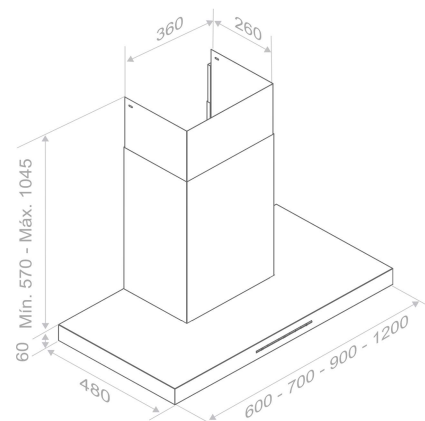

■ Tubos especiales a medida  
Special custom-made chimneys



Acceso / Acces WEB



Pared / Wall



**P-825**

# P-826 Inox Stainless Steel

Frontal cristal negro o blanco  
Black/white glass front

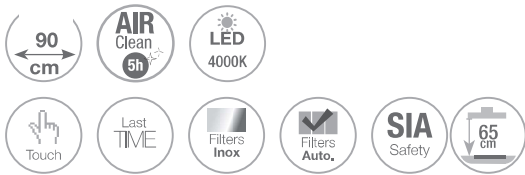

Modelos / Models

## S.E.C. System®

### Motor Interior / Interior Motor

Front. (cm)	Motor	Ø tubo	Clas. Ener.	Ref.	P.V.R
<b>Frontal Negro / Black Front</b>					
90	V.750	Ø125	B	008876	895 €
	V.850	Ø150	A+	008527	895 €
<b>Frontal Blanco / White Front</b>					
90	V.750	Ø125	B	009024	895 €
	V.850	Ø150	A+	009025	895 €

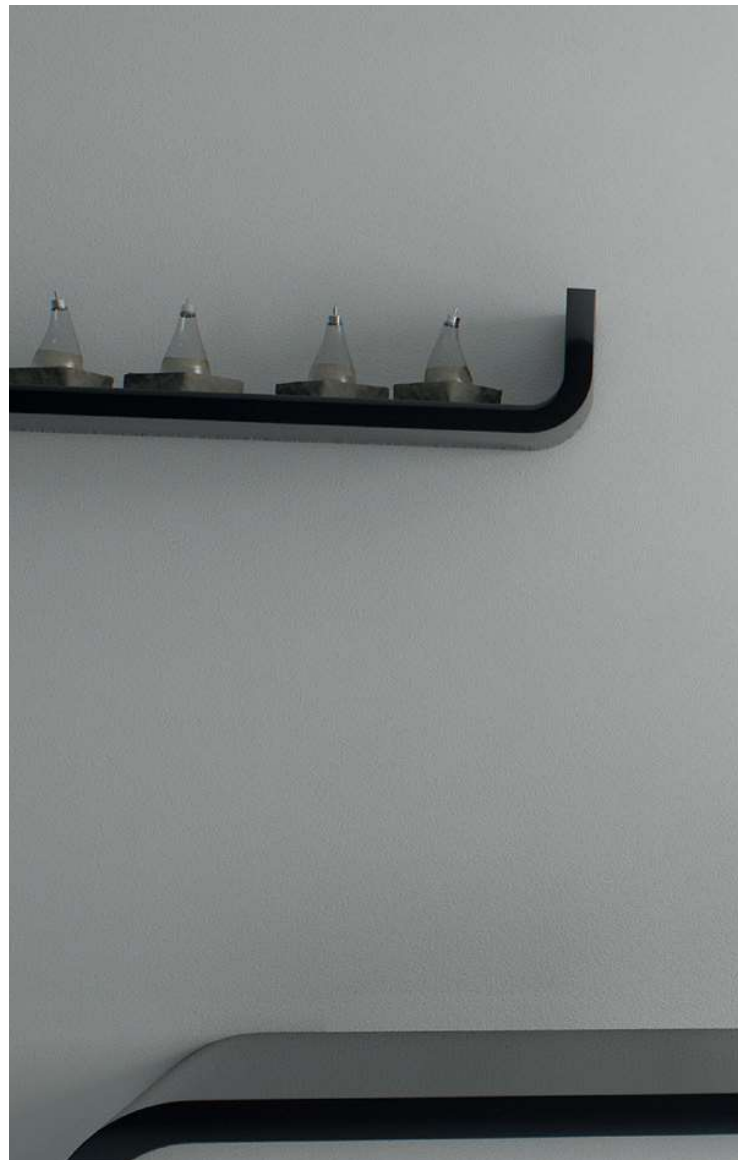

Pared / Wall

Opcionales / Options

### AirLink

Modelo compatible. Es imprescindible solicitar esta opción en el pedido de la campana. No se equipa de serie. 0 €  
Compatible Model. This option must be requested together with the purchase order. Is not included as standard.

Embellecedor a techo. Ref. 7118. (indicar modelo y medida de la campana) 120 €  
Ceiling trim. Ref. 7118. (Specify reference)

Kits de recirculación. Ver página 210  
Activated carbon filters kit. See page 210

Substitución del LED original por el sistema Pando Led 80 €  
Change of the original LED to the Pando LED system

Mando a distancia Touch. Suministrado con la campana. 120 €  
Remote Control Touch supplied together with the hood.

Juego de tubos hasta altura total de 1500 mm 180 €  
Set of chimneys to a total height of 1500 mm  
(Indicar la medida en su pedido) - (Indicate the size in your order)

Juego de tubos hasta altura total de entre 1501 y 2000 mm 220 €  
Set of chimneys to a total height of between 1501 and 2000 mm  
(Indicar la medida en su pedido) - (Indicate the size in your order)

Notas / Notes

### AirClean

Sistema automático de funcionamiento del motor 10 min. cada hora durante 5 horas.  
Automatic working motor system for 10 minutes every hour during 5 hours.

Esquemas medidas / Technical Drawings

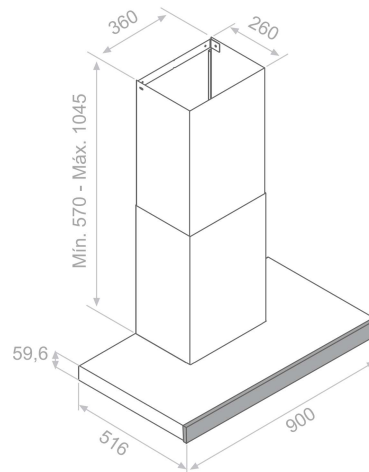

Tubos especiales a medida / Special custom-made chimneys



Acceso / Acces WEB



Pared / Wall



**P-826**



# P-827 Inox Stainless Steel

**Frontal negro**  
**Black front**



Modelos / Models

## S.E.C. System® Motor Interior / Interior Motor

Front. (cm)	Motor	Ø tubo	Clas. Ener.	Ref.	P.V.R
90	V.850	Ø150	A	009934	995 €



Pared / Wall

Opcionales / Options

### AirLink

Modelo compatible. Es imprescindible solicitar esta opción en el pedido de la campana. No se equipa de serie. 0 €  
Compatible Model. This option must be requested together with the purchase order. Is not included as standard.

Embellecedor a techo. Ref. 7118. (indicar modelo y medida de la campana) 120 €  
Ceiling trim. Ref. 7118. (Specify reference)

Kits de recirculación. Ver página 210  
Activated carbon filters kit. See page 210

Mando a distancia Touch. Suministrado con la campana. 120 €  
Remote Control Touch supplied together with the hood.

Juego de tubos hasta altura total de 1500 mm 180 €  
Set of chimneys to a total height of 1500 mm  
(Indicar la medida en su pedido) - (Indicate the size in your order)

Juego de tubos hasta altura total de entre 1501 y 2000 mm 220 €  
Set of chimneys to a total height of between 1501 and 2000 mm  
(Indicar la medida en su pedido) - (Indicate the size in your order)

Notas / Notes

### AirClean

Sistema automático de funcionamiento del motor 10 min. cada hora durante 5 horas.  
Automatic working motor system for 10 minutes every hour during 5 hours.

Esquemas medidas / Technical Drawings

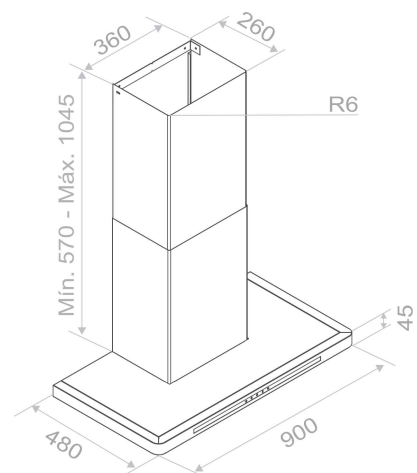

Tubos especiales a medida / Special custom-made chimneys



Acceso / Acces WEB



Pared / Wall



**P-827**

# P-842/6 P-842/11

Inox  
Stainless Steel



Realizada a medida  
Custom made

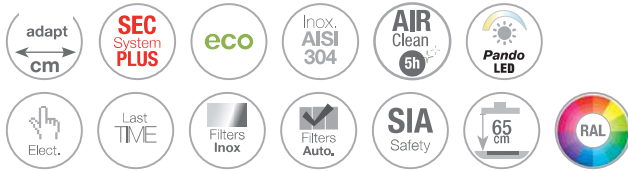

Modelos / Models

## S.E.C. System®

### Motor Interior / Interior Motor

Motor	Ø tubo
V.1050 eco SEC® PLUS	Ø150
V.1250 eco	Ø150
V.2220 eco	Ø200

### Motor Intermedio exterior / Duct-in-line motor

V.1550 eco	Ø150
V.2450 eco	Ø200
V.3000 eco	Ø200

### Motor de tejado / Remote motor -Roof Outdoor

V.2350 eco	Ø200
V.3300 eco	Ø200

Opcionales / Options

## AirLink

Modelo compatible. Es imprescindible solicitar esta opción en el pedido de la campana. No se equipa de serie. 0 €  
Compatible Model. This option must be requested together with the purchase order. Is not included as standard.

Embellecedor a techo, Ref. 7118, (indicar modelo y medida de la campana) 120 €  
Ceiling trim. Ref. 7118. (Specify reference)

Kits de recirculación. Bajo presupuesto  
Activated carbon filters kit. On request

Mando a distancia Touch. Suministrado con la campana. 120 €  
Remote Control Touch supplied together with the hood.

Notas / Notes

## AirClean

Sistema automático de funcionamiento del motor 10 min. cada hora durante 5 horas.  
Automatic working motor system for 10 minutes every hour during 5 hours.

Para modelos con carbón activado las medidas de los tubos serán:  
The flues will be as follows for models with activated carbon: Min. 645 - Máx. 1045

### Bajo presupuesto / On request

Modelo personalizable en cualquier color de la carta RAL  
Customizable model in any color from the RAL chart

### Bajo presupuesto / On request

Enchufes y conectores USB  
Plugs and USB connectors



La botonera siempre irá ubicada centrada debajo del tubo de extracción. Por ello, según el tubo se sitúe en la derecha o en la izquierda de la campana, la botonera también variará su posición.

The control panel is always positioned centrally under the extraction tube. Therefore, depending on whether the tube is located on the right or left side of the cooker hood, the position of the control panel will also vary.

Esquemas medidas / Technical Drawings

\*Para motores V.2200 ECO, la medida del tubo debe ser 470x330.  
Access to the scheme to confirm hood dimension details.

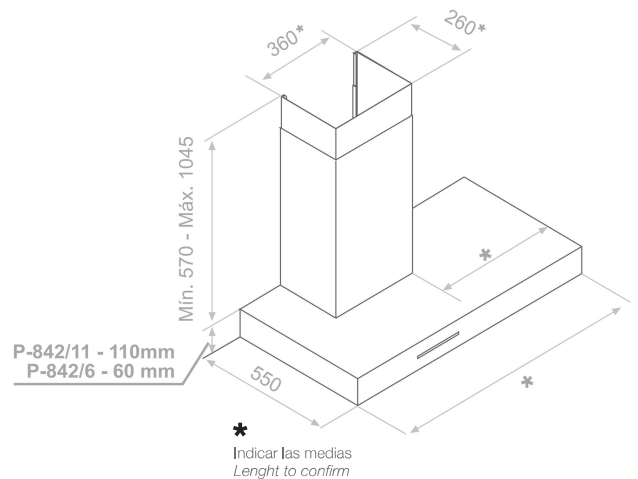

Acceso / Acces WEB

Acceso a esquemas para confirmar las medidas.  
Access to the scheme to confirm hood dimension details.



**P-842/11. Altura de 11 cm del cuerpo de la campana.**  
P-842/11. 11 cm height of cooker hood body



**P-842/6. Altura de 6 cm del cuerpo de la campana.**  
P-842/6. 6 cm height of cooker hood body

**P-842/6**  
**P-842/11**







**P-861**

# P-861

Inox - Esmantado Negro  
Stainless Steel - Black enamel

90 cm  
105 cm  
120 cm  
140 cm  
150 cm  
180 cm



Modelos / Models

## Inox / Stainless Steel

### S.E.C. System®

#### Motor Interior / Interior Motor

Front. (cm)	Motor	Ø tubo	Clas. Ener.	Ref.	P.V.R
90	V.850	Ø150	A	009331	1.475 €
	V.1050 eco SEC® PLUS	Ø150	A	009332	1.695 €
	V.1250 eco	Ø150	A+	008713	1.895 €
105	V.850	Ø150	A	009337	1.595 €
	V.1050 eco SEC® PLUS	Ø150	A	009338	1.795 €
	V.1250 eco	Ø150	A+	008724	1.995 €
120	V.850	Ø150	A	009343	1.795 €
	V.1050 eco SEC® PLUS	Ø150	A	009344	1.995 €
	V.1250 eco	Ø150	A+	008735	2.195 €
140	V.1250 eco	Ø150	A	008744	2.545 €
	V.1250 eco	Ø150	A	008753	2.895 €
180	V.1250 eco	Ø150	A	008762	3.145 €

#### Motor Intermedio exterior / Duct-in-line motor

90	V.1550 eco	Ø150	A+	009333	2.295 €
	V.2450 eco	Ø200	A+	009335	2.745 €
105	V.1550 eco	Ø150	A	009339	2.445 €
	V.2450 eco	Ø200	A	009341	2.895 €
120	V.1550 eco	Ø150	A	009345	2.595 €
	V.2450 eco	Ø200	A	009347	2.995 €
140	V.1550 eco	Ø150	A	009350	2.995 €
	V.2450 eco	Ø200	A	009352	3.395 €
150	V.1550 eco	Ø150	A	009355	3.345 €
	V.2450 eco	Ø200	A	009357	3.745 €
180	V.1550 eco	Ø150	A	009359	3.545 €
	V.2450 eco	Ø200	A	009361	3.895 €

#### Motor de tejado / Remote motor -Roof Outdoor

90	V.2350 eco	Ø200	A+	009336	2.845 €
105	V.2350 eco	Ø200	A	009342	2.995 €
120	V.2350 eco	Ø200	A	009348	3.095 €
140	V.2350 eco	Ø200	A	009353	3.495 €
150	V.2350 eco	Ø200	A	009358	3.845 €
180	V.2350 eco	Ø200	A	009362	3.995 €

## Negro satinado / Satin black

### S.E.C. System®

#### Motor Interior / Interior Motor

Front. (cm)	Motor	Ø tubo	Clas. Ener.	Ref.	P.V.R
90	V.850	Ø150	A	010375	1.895 €
	V.1050 eco SEC® PLUS	Ø150	A	010376	2.095 €
	V.1250 eco	Ø150	A+	010377	2.295 €
105	V.850	Ø150	A	010381	1.995 €
	V.1050 eco SEC® PLUS	Ø150	A	010382	2.195 €
	V.1250 eco	Ø150	A+	010383	2.395 €
120	V.850	Ø150	A	010387	2.195 €
	V.1050 eco SEC® PLUS	Ø150	A	010388	2.395 €
	V.1250 eco	Ø150	A+	010389	2.595 €
140	V.1250 eco	Ø150	A	010393	2.945 €
	V.1250 eco	Ø150	A	010397	3.295 €
180	V.1250 eco	Ø150	A	010401	3.545 €

#### Motor Intermedio exterior / Duct-in-line motor

90	V.1550 eco	Ø150	A	010378	2.695 €
	V.2450 eco	Ø200	A	010379	3.145 €
105	V.1550 eco	Ø150	A	010384	2.895 €
	V.2450 eco	Ø200	A	010385	3.295 €
120	V.1550 eco	Ø150	A	010390	2.995 €
	V.2450 eco	Ø200	A	010391	3.395 €
140	V.1550 eco	Ø150	A	010394	3.395 €
	V.2450 eco	Ø200	A	010395	3.795 €
150	V.1550 eco	Ø150	A	010398	3.745 €
	V.2450 eco	Ø200	A	010399	4.145 €
180	V.1550 eco	Ø150	A	010402	3.945 €
	V.2450 eco	Ø200	A	010403	4.295 €

#### Motor de tejado / Remote motor -Roof Outdoor

90	V.2350 eco	Ø200	A	010380	3.245 €
105	V.2350 eco	Ø200	A	010386	3.395 €
120	V.2350 eco	Ø200	A	010392	3.495 €
140	V.2350 eco	Ø200	A	010396	3.895 €
150	V.2350 eco	Ø200	A	010400	4.245 €
180	V.2350 eco	Ø200	A	010404	4.395 €

Opcionales / Options

### AirLink

Modelo compatible. Es imprescindible solicitar esta opción en el pedido de la campana. No se equipa de serie

Compatible Model. This option must be requested together with the purchase order.

Is not included as standard.

Embellecedor a techo. Ref. 7118. (indicar modelo y medida de la campana)  
Ceiling trim. Ref. 7118. (Specify reference)

Kits de recirculación. Ver página 210  
Activated carbon filters kit. See page 210

Mando a distancia Touch. Suministrado con la campana.  
Remote Control Touch supplied together with the hood.

0 €

120 €

120 €

Opcionales / Options

Juego de tubos INOX hasta altura total de 1500 mm  
Stainless steel chimney set to a total height of 1500 mm

180 €

Juego de tubos INOX hasta altura total de entre 1501 y 2000 mm  
Stainless steel chimney set to a total height of between 1501 and 2000 mm

220 €

Juego de tubos NEGRO SATINADO hasta altura total de 1500 mm  
BLACK chimney set to a total height of 1500 mm

290 €

Juego de tubos NEGRO SATINADO hasta altura total de entre 1501 y 2000 mm  
BLACK chimney set to a total height of between 1501 and 2000 mm

375 €





Model. 180 cm

Pared / Wall

Esquemas medidas / Technical Drawings

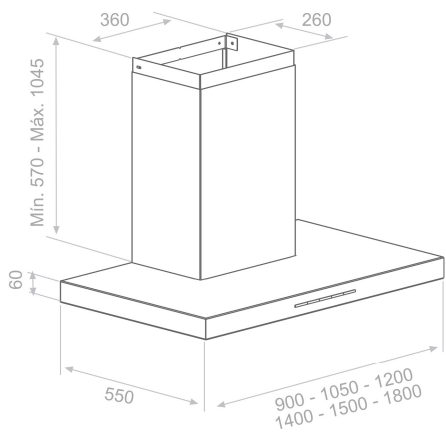

Acceso / Acces WEB

■ Tubos especiales a medida / Special custom-made chimneys

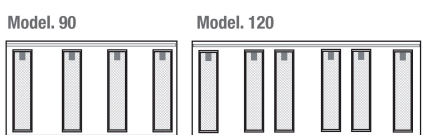

Ejemplo distribución de la bandeja inferior. Para campanas de otras medidas consultar distribución de la bandeja inferior.  
Sample bottom tray layout. For hoods in other sizes, consult bottom tray layout.

Notas / Notes

**AirClean**  
Sistema automático de funcionamiento del motor 10 min. cada hora durante 5 horas.  
Automatic working motor system for 10 minutes every hour during 5 hours.

Sistema BOP aplicado en en todas las medidas.  
BOP system in all sizes.

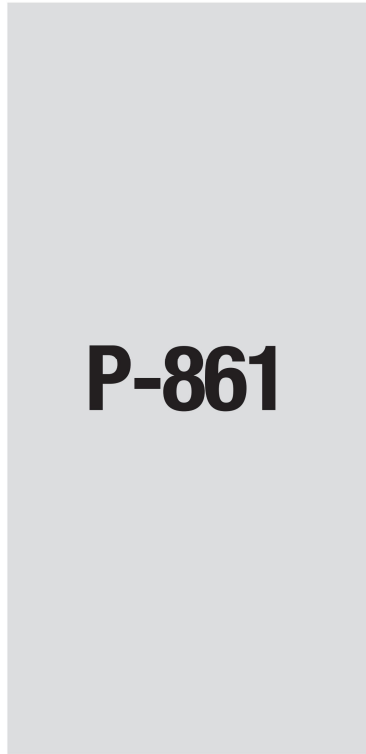



# P-898 Inox Stainless Steel

## Realizada a medida Custom made

Inox esmaltado con color de la carta RAL  
Colección especial en negro 9005  
Opción de 1 o 2 racks

Enamel Stainless steel from RAL color Chart.  
Special collection in black 9005  
Option of 1 or 2 racks



### Modelos / Models

#### S.E.C. System®

##### Motor Interior / Interior Motor

Motor	Ø tubo
V.1250 <i>eco</i>	Ø150
V.2200 <i>eco</i>	Ø200

##### Motor Intermedio exterior / Duct-in-line motor

V.1550 <i>eco</i>	Ø150
V.2450 <i>eco</i>	Ø200

##### Motor de tejado / Remote motor -Roof Outdoor

V.2350 <i>eco</i>	Ø200
-------------------	------

### Opcionales / Options

#### AirLink

Modelo compatible. Es imprescindible solicitar esta opción en el pedido de la campana. No se equipa de serie  
Compatible Model. This option must be requested together with the purchase order.  
Is not included as standard.

0 €

Mando a distancia Touch. Suministrado con la campana.  
Remote Control Touch supplied together with the hood.

120 €

Kits de recirculación. Bajo presupuesto  
Activated carbon filters kit. On request

### Notas / Notes

#### AirClean

Sistema automático de funcionamiento del motor 10 min. cada hora durante 5 horas.  
Automatic working motor system for 10 minutes every hour during 5 hours.

#### Bajo presupuesto / On request

Modelo personalizable en cualquier color de la carta RAL  
Customizable model in any color from the RAL chart

#### Bajo presupuesto / On request

Enchufes y conectores USB  
Plugs and USB connectors



### Esquemas medidas / Technical Drawings

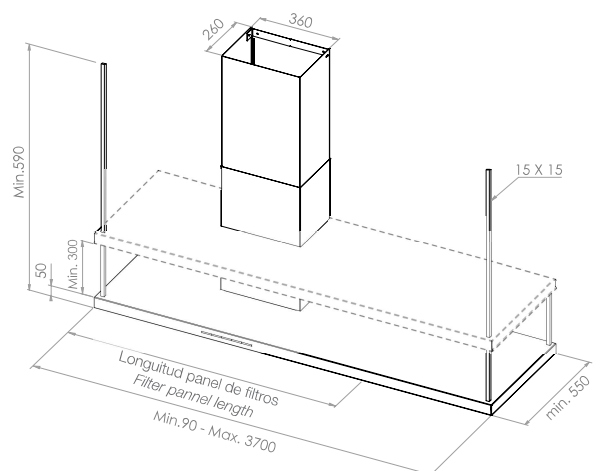

Opción de 1 o 2 racks / Option of 1 or 2 racks



Acceso / Acces WEB



Pared / Wall

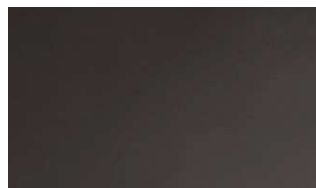

Negro mate RAL 9005  
Black mat RAL 9005



Negro satinado  
Black satin

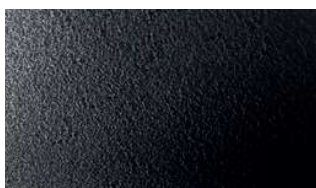

Negro texturado  
Textured black

**P-898**

# P-960 Inox Stainless Steel

**Cristal Negro o Blanco óptico**  
Black glass or Optical white



Modelos / Models

## S.E.C. System® Motor Interior / Interior Motor

Front. (cm)	Motor	Ø tubo	Clas. Ener.	Ref.	P.V.R
<b>Inox / Stainless Steel</b>					
100	V.1250 eco	Ø150	A+	009400	1.995 €
<b>Cristal Negro / Black glass</b>					
100	V.1250 eco	Ø150	A+	009404	2.175 €
<b>Blanco óptico / Optical white</b>					
100	V.1250 eco	Ø150	A+	009402	2.175 €

Pared / Wall



Opcionales / Options

### AirLink

Modelo compatible. Es imprescindible solicitar esta opción en el pedido de la campana. No se equipa de serie. 0 €  
Compatible Model. This option must be requested together with the purchase order. Is not included as standard.

Embellecedor a techo. Ref. 7118. (indicar modelo y medida de la campana) 120 €  
Ceiling trim. Ref. 7118. (Specify reference)

Kits de recirculación. Ver página 210  
Activated carbon filters kit. See page 210

Mando a distancia Touch. Suministrado con la campana. 120 €  
Remote Control Touch supplied together with the hood.

Juego de tubos hasta altura total de 1500 mm 180 €  
Set of chimneys to a total height of 1500 mm  
(Indicar la medida en su pedido) - (Indicate the size in your order)

Juego de tubos hasta altura total de entre 1501 y 2000 mm 220 €  
Set of chimneys to a total height of between 1501 and 2000 mm  
(Indicar la medida en su pedido) - (Indicate the size in your order)

Notas / Notes

### AirClean

Sistema automático de funcionamiento del motor 10 min. cada hora durante 5 horas.  
Sólo en el modelo cristal con touch control.  
Automatic working motor system for 10 minutes every hour during 5 hours.  
Only in touch control model.

Apto sólo para encimeras de máximo 900 x 350 mm.  
Suitable only for hobs of a maximum of 900 x 350 mm.

Esquemas medidas / Technical Drawings

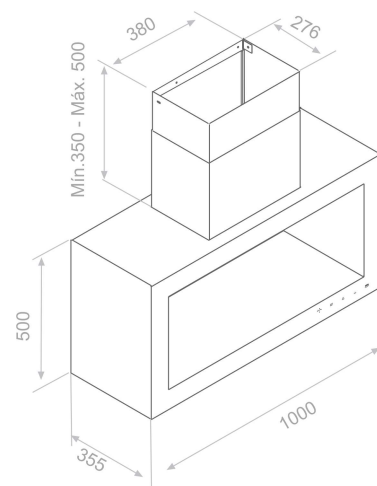

Tubos especiales a medida / Special custom-made chimneys



Acceso / Acces WEB



Pared / Wall

**P-960**





# P-1001

Inox  
Stainless Steel



## Modelos / Models

### Motor Interior / Interior Motor

Front. (cm)	Motor	Ø tubo	Clas. Ener.	Ref.	P.V.R
90	V.1050 eco	Ø150	A++	009406	2.295 €
	V.1250 eco	Ø150	A++	008531	2.495 €
	V.2200 eco	Ø200	A	010232	3.395 €
120	V.1050 eco	Ø150	A++	009412	2.595 €
	V.1250 eco	Ø150	A++	008541	2.795 €
	V.2200 eco	Ø200	A	010233	3.695 €

### Motor Intermedio exterior / Duct-in-line motor

90	V.1550 eco	Ø150	A+	009408	2.895 €
	V.2450 eco	Ø200	A+	009410	3.295 €
120	V.1550 eco	Ø150	A+	009414	3.195 €
	V.2450 eco	Ø200	A+	009416	3.595 €

### Motor de tejado / Remote motor -Roof Outdoor

90	V.2350 eco	Ø200	A+	009411	3.395 €
120	V.2350 eco	Ø200	A++	009417	3.695 €



## Opcionales / Options

### AirLink

Modelo compatible. Es imprescindible solicitar esta opción en el pedido de la campana. No se equipa de serie. 0 €  
Compatible Model. This option must be requested together with the purchase order. Is not included as standard.

Embellecedor a techo. Ref. 7118. (indicar modelo y medida de la campana) 120 €  
Ceiling trim. Ref. 7118. (Specify reference)

Mando a distancia Touch. Suministrado con la campana. 120 €  
Remote Control Touch supplied together with the hood.

Juego de tubos hasta altura total de 1500 mm 180 €  
Set of chimneys to a total height of 1500 mm  
(Indicar la medida en su pedido) - (Indicate the size in your order)

Juego de tubos hasta altura total de entre 1501 y 2000 mm 220 €  
Set of chimneys to a total height of between 1501 and 2000 mm  
(Indicar la medida en su pedido) - (Indicate the size in your order)

## Notas / Notes

### AirClean

Sistema automático de funcionamiento del motor 10 min. cada hora durante 5 horas.  
Automatic working motor system for 10 minutes every hour during 5 hours.

Incorpora exclusivamente opción de recirculación mediante difusor a techo con filtro cerámico.  
It exclusively incorporates the recirculation option by means of ceiling diffuser with ceramic filter.

Incorpora bandeja de fácil limpieza que recoge las grasas de la cocción.  
Includes easy-cleaning tray for collection of oil.

Medidas especiales bajo presupuesto.  
Custom-made sizes on request.

## Esquemas medidas / Technical Drawings

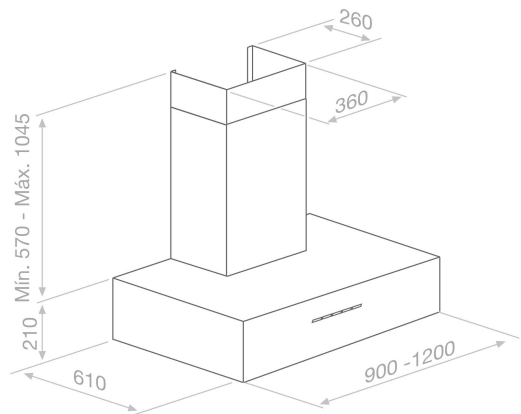

Opcional a medida.  
Can be custom made.

■ Tubos especiales a medida / Special custom-made chimneys



Acceso / Acces WEB



Pared / Wall



**P-1001**

# P-2000

Inox  
Stainless Steel



Modelos / Models

## S.E.C. System® Motor Interior / Interior Motor

Front. (cm)	Motor	Ø tubo	Clas. Ener.	Ref.	P.V.R
100	V.1050 eco	Ø150	A++	009738	2.295 €
	V.1250 eco	Ø150	A++	009740	2.495 €
120	V.1050 eco	Ø150	A++	009739	2.495 €
	V.1250 eco	Ø150	A++	009741	2.695 €
150	V.1250 eco	Ø150	A++	009742	2.895 €
	V.2200 eco	Ø200	A	010236	3.895 €



Pared / Wall

Opcionales / Options

### AirLink

Modelo compatible. Es imprescindible solicitar esta opción en el pedido de la campana. No se equipa de serie. 0 €  
Compatible Model. This option must be requested together with the purchase order. Is not included as standard.

Embellecedor a techo. Ref. 7118. (indicar modelo y medida de la campana) 120 €  
Ceiling trim. Ref. 7118. (Specify reference)

Mando a distancia Touch. Suministrado con la campana. 120 €  
Remote Control Touch supplied together with the hood.

Salida trasera. Indicar en pedido. 120 €  
Specify on order in the case of rear exit.

Juego de tubos hasta altura total de 1500 mm 180 €  
Set of chimneys to a total height of 1500 mm  
(Indicar la medida en su pedido) - (Indicate the size in your order)

Juego de tubos hasta altura total de entre 1501 y 2000 mm 220 €  
Set of chimneys to a total height of between 1501 and 2000 mm  
(Indicar la medida en su pedido) - (Indicate the size in your order)

Notas / Notes

### AirClean

Sistema automático de funcionamiento del motor 10 min. cada hora durante 5 horas.  
Automatic working motor system for 10 minutes every hour during 5 hours.

Incorpora exclusivamente opción de recirculación mediante difusor a techo con filtro cerámico.  
It exclusively incorporates the recirculation option by means of ceiling diffuser with ceramic filter.

Incorpora bandeja de fácil limpieza que recoge las grasas de la cocción.  
Includes easy-cleaning tray for collection of oil.

Medidas especiales bajo presupuesto.  
Custom-made sizes on request.

Esquemas medidas / Technical Drawings

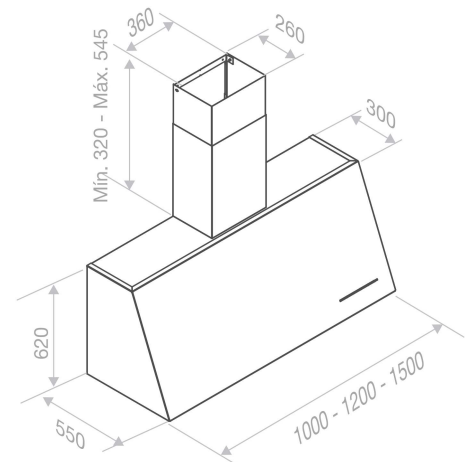

Opcional a medida.  
Can be custom made.

Tubos especiales a medida / Special custom-made chimneys



Acceso / Acces WEB





Pared / Wall



**P-2000**



# P-2000 VINTAGE

Cobre o Oro Luxury.  
Opción de realizarla a medida.  
Copper or Luxury Gold.  
Can be custom made.



Modelos / Models

## S.E.C. System®

### Motor Interior / Interior Motor

Front. (cm)	Motor	Ø tubo	Clas. Ener.	Ref.	P.V.R
<b>Cobre / Copper</b>					
100	V.1050 eco	Ø150	A++	009853	2.695 €
	V.1250 eco	Ø150	A++	009854	2.995 €
120	V.1050 eco	Ø150	A++	009855	2.995 €
	V.1250 eco	Ø150	A++	009856	3.295 €
150	V.1250 eco	Ø150	A++	009857	3.395 €
	V.2200 eco	Ø200	A	010239	4.295 €
<b>Oro / Luxury Gold</b>					
100	V.1050 eco	Ø150	A++	009896	2.695 €
	V.1250 eco	Ø150	A++	009897	2.995 €
120	V.1050 eco	Ø150	A++	009898	2.995 €
	V.1250 eco	Ø150	A++	009899	3.295 €
150	V.1250 eco	Ø150	A++	009900	3.395 €
	V.2200 eco	Ø200	A	010242	4.295 €

Pared / Wall

Esquemas medidas / Technical Drawings

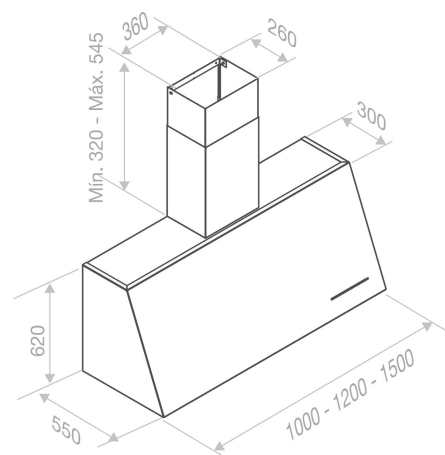

Opcional a medida.  
Can be custom made.

Tubos especiales a medida / Special custom-made chimneys



Acceso / Acces WEB

Opcionales / Options

### AirLink

Modelo compatible. Es imprescindible solicitar esta opción en el pedido de la campana. No se equipa de serie. 0 €  
Compatible Model. This option must be requested together with the purchase order. Is not included as standard.

Embellecedor a techo. Ref. 7118, (indicar modelo y medida de la campana) 120 €  
Ceiling trim. Ref. 7118. (Specify reference)

Mando a distancia Touch. Suministrado con la campana. 120 €  
Remote Control Touch supplied together with the hood.

Salida trasera. Indicar en pedido. 120 €  
Specify on order in the case of rear exit.

Juego de tubos hasta altura total de 1500 mm 450 €  
Set of chimneys to a total height of 1500 mm  
(Indicar la medida en su pedido) - (Indicate the size in your order)

Juego de tubos hasta altura total de entre 1501 y 2000 mm 560 €  
Set of chimneys to a total height of between 1501 and 2000 mm  
(Indicar la medida en su pedido) - (Indicate the size in your order)

Notas / Notes

### AirClean

Sistema automático de funcionamiento del motor 10 min. cada hora durante 5 horas.  
Automatic working motor system for 10 minutes every hour during 5 hours.

Incorpora exclusivamente opción de recirculación mediante difusor a techo con filtro cerámico.  
It exclusively incorporates the recirculation option by means of ceiling diffuser with ceramic filter.

Incorpora bandeja de fácil limpieza que recoge las grasas de la cocción.  
Includes easy-cleaning tray for collection of oil.



Pared / Wall

## P-2000 VINTAGE







**P-2010**





# P-2010

Inox, Cobre, Luxury Oro / Blanco RAL 9003  
 Negro Mate / Negro satinado / Negro texturado  
 Stainless Steel, Copper or Luxury Gold  
 White RAL 9003 / Black Matt / Satin Black  
 Textured Black



## Opcionales / Options

### AirLink

Modelo compatible. Es imprescindible solicitar esta opción en el pedido de la campana. No se equipa de serie  
 Compatible Model. This option must be requested together with the purchase order.  
 Is not included as standard.

0 €

Embellecedor a techo. Ref. 7118. (indicar modelo y medida de la campana)  
 Ceiling trim. Ref. 7118. (Specify reference)

120 €

Mando a distancia Touch. Suministrado con la campana.  
 Remote Control Touch supplied together with the hood.

120 €

Kits de recirculación. Ver página 210  
 Activated carbon filters kit. See page 210

Salida trasera. Indicar en pedido.  
 Specify on order in the case of rear exit.

120 €

Juego de tubos INOX hasta altura total de 1500 mm  
 Set of STAINLESS STEEL chimneys to a total height of 1500 mm  
 (Indicar la medida en su pedido) - (Indicate the size in your order)

180 €

Juego de tubos INOX hasta altura total de entre 1501 y 2000 mm  
 Set of STAINLESS STEEL chimneys to a total height of between 1501 and 2000 mm  
 (Indicar la medida en su pedido) - (Indicate the size in your order)

220 €

Juego de tubos ORO/COBRE hasta altura total de 1500 mm  
 Set of GOLD/COPPER chimneys to a total height of 1500 mm  
 (Indicar la medida en su pedido) - (Indicate the size in your order)

380 €

Juego de tubos ORO/COBRE hasta altura total de entre 1501 y 2000 mm  
 Set of GOLD/COPPER chimneys to a total height of between 1501 and 2000 mm  
 (Indicar la medida en su pedido) - (Indicate the size in your order)

480 €

Juego de tubos BLANCO/NEGRO hasta altura total de 1500 mm  
 Set of WHITE/BLACK chimneys to a total height of 1500 mm  
 (Indicar la medida en su pedido) - (Indicate the size in your order)

290 €

Juego de tubos BLANCO/NEGRO hasta altura total de entre 1501 y 2000 mm  
 Set of WHITE/BLACK chimneys to a total height of between 1501 and 2000 mm  
 (Indicar la medida en su pedido) - (Indicate the size in your order)

375 €

## Notas / Notes

### AirClean

Sistema automático de funcionamiento del motor 10 min. cada hora durante 5 horas.  
 Automatic working motor system for 10 minutes every hour during 5 hours.

## Modelos / Models

### S.E.C. System®

#### Motor Interior / Interior Motor

Front. (cm)	Motor	Ø tubo	Clas. Ener.	Ref.	P.V.R
<b>Inox / Stainless Steel</b>					
90	V.850	Ø150	A++	009860	1.295 €
	V.1050 eco	Ø150	A++	009861	1.495 €
	V.1250 eco	Ø150	A++	009862	1.695 €
120	V.850	Ø150	A++	009878	1.595 €
	V.1050 eco	Ø150	A++	009879	1.795 €
	V.1250 eco	Ø150	A++	009880	1.995 €
<b>Negro mate RAL 9005 / RAL 9005 Black matt</b>					
90	V.850	Ø150	A++	009869	1.495 €
	V.1050 eco	Ø150	A++	009870	1.695 €
	V.1250 eco	Ø150	A++	009871	1.895 €
120	V.850	Ø150	A++	009887	1.795 €
	V.1050 eco	Ø150	A++	009888	1.995 €
	V.1250 eco	Ø150	A++	009889	2.195 €
<b>Negro satinado / Satin black</b>					
90	V.850	Ø150	A++	009872	1.495 €
	V.1050 eco	Ø150	A++	009873	1.695 €
	V.1250 eco	Ø150	A++	009874	1.895 €
120	V.850	Ø150	A++	009890	1.795 €
	V.1050 eco	Ø150	A++	009891	1.995 €
	V.1250 eco	Ø150	A++	009892	2.195 €
<b>Negro texturado / Textured black</b>					
90	V.850	Ø150	A++	009875	1.595 €
	V.1050 eco	Ø150	A++	009876	1.795 €
	V.1250 eco	Ø150	A++	009877	1.995 €
120	V.850	Ø150	A++	009893	1.895 €
	V.1050 eco	Ø150	A++	009894	2.095 €
	V.1250 eco	Ø150	A++	009895	2.295 €
<b>Blanco / White RAL 9003</b>					
90	V.850	Ø150	A++	009942	1.495 €
	V.1050 eco	Ø150	A++	009943	1.695 €
	V.1250 eco	Ø150	A++	009944	1.895 €
120	V.850	Ø150	A++	009945	1.795 €
	V.1050 eco	Ø150	A++	009946	1.995 €
	V.1250 eco	Ø150	A++	009947	2.195 €
<b>Cobre / Luxury Copper</b>					
90	V.850	Ø150	A++	009863	1.795 €
	V.1050 eco	Ø150	A++	009864	1.995 €
	V.1250 eco	Ø150	A++	009865	2.195 €
120	V.850	Ø150	A++	009881	2.395 €
	V.1050 eco	Ø150	A++	009882	2.595 €
	V.1250 eco	Ø150	A++	009883	2.795 €
<b>Oro / Luxury Gold</b>					
90	V.850	Ø150	A++	009866	1.795 €
	V.1050 eco	Ø150	A++	009867	1.995 €
	V.1250 eco	Ø150	A++	009868	2.195 €
120	V.850	Ø150	A++	009884	2.395 €
	V.1050 eco	Ø150	A++	009885	2.595 €
	V.1250 eco	Ø150	A++	009886	2.795 €



Pared / Wall

Esquemas medidas / Technical Drawings

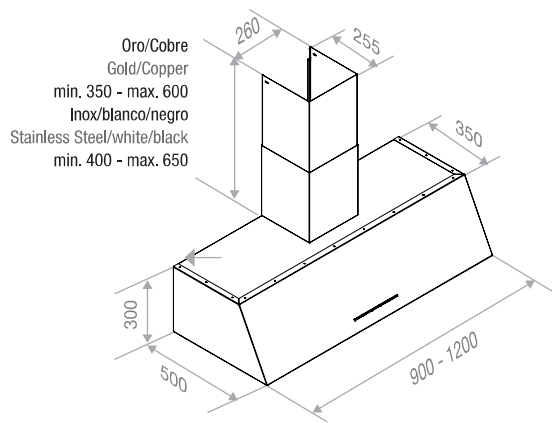

■ Tubos especiales a medida / Special custom-made chimneys



Acceso / Acces WEB

# P-2010



# CAMPANAS DE ISLA

## ISLAND COOKER HOODS

Isia / Island









# I-300

Inox  
Stainless Steel

# I-330

Inox -Cristal  
Stainless Steel-Glass  
Touch control

**Realizadas a medida.  
Custom Made.**



Modelos / Models

### S.E.C. System® Interior / Interior

Motor	Ø tubo
V.1250 eco	Ø150
V.2200 eco	Ø200

### Intermedio exterior / Duct-in-line motor

V.1550 eco	Ø150
V.2450 eco	Ø200
V.3000 eco	Ø200

### De tejado / Remote motor -Roof Outdoor

V.2350 eco	Ø200
V.3300 eco	Ø200

Opcionales / Options

### AirLink

Modelo compatible. Es imprescindible solicitar esta opción en el pedido de la campana. No se equipa de serie  
Compatible Model. This option must be requested together with the purchase order. Is not included as standard.

0 €

Embellecedor a techo.  
Ceiling trim.

Kits de recirculación. Bajo presupuesto  
Activated carbon filters kit. On request

Mando a distancia Touch. Suministrado con la campana.  
Remote Control Touch supplied together with the hood. 120 €

### Bajo presupuesto / On request

Soporte falso techo. Indicar medida del falso techo al techo real.  
False Ceiling Support. Specified sizes from ceiling to concrete ceiling

Notas / Notes

### I-330

Botonera TOUCH únicamente en acabados blanco o negro brillo.  
TOUCH control only in glossy black or white finish.

Resto de colores, incorporan botonera electrónica + Last Time en zona inferior.  
The rest of the colours incorporate electronic control + Last Time in lower section.

### I-330 - AirClean

Sistema automático de funcionamiento del motor 10 min. cada hora durante 5 horas.  
Automatic working motor system for 10 minutes every hour during 5 hours.

### Bajo presupuesto / On request

Modelo personalizable en cualquier color de la carta RAL  
Customizable model in any color from the RAL chart



Acceso / Acces WEB  
I-300



Acceso / Acces WEB  
I-330

Acceso a esquemas para confirmar las medidas.  
Access to the scheme to confirm hood dimension details.



Esquemas medidas / Technical Drawings

Altura mínima para campanas especiales 500 mm.  
Minimum height for special hoods 500 mm.

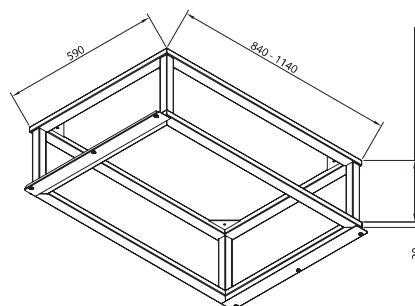
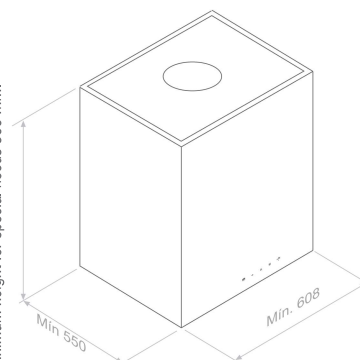

Medidas a indicar por el Sr. Cliente.  
Size to be indicated by the customer

Soporte falso techo opcional/ Optional false ceiling support.



Touch

Model. 90 cm

Isla / Island



Elect.

Model. 90 cm

**I-300**  
**I-330**

# I-402

Inox  
Stainless Steel



## Modelos / Models

### S.E.C. System®

#### Motor Interior / Interior Motor

Front. (cm)	Motor	Ø tubo	Clas. Ener.	Ref.	P.V.R
90	V.1250 eco	Ø150	A+	008387	2.195 €
120	V.1250 eco	Ø150	A+	008390	2.895 €

#### Intermedio exterior / Duct-in-line

90	V.1550 eco	Ø150	A+	009435	2.595 €
120	V.1550 eco	Ø150	A+	009437	3.295 €

#### De tejado / Remote: Roof Outdoor

90	V.2350 eco	Ø200	A+	009436	3.195 €
120	V.2350 eco	Ø200	A+	009438	3.995 €

## Opcionales / Options

### AirLink

Modelo compatible. Es imprescindible solicitar esta opción en el pedido de la campana. No se equipa de serie

Compatible Model. This option must be requested together with the purchase order. Is not included as standard.

0 €

Embellecedor a techo. Ref. 7116 para la medida 120cm.  
Ceiling trim. Ref. 7116 for the size 120cm.

160 €

Mando a distancia Touch. Suministrado con la campana.  
Remote Control Touch supplied together with the hood.

120 €

Soporte falso techo regulable 90 cm de 150 a 240 mm. Ref. 3589  
False ceiling support adjustable 90 cm from 150 to 340 mm. Ref. 3589

170 €

Soporte falso techo regulable 90 cm de 250 a 440 mm. Ref. 3590  
False ceiling support adjustable 90 cm from 250 to 440 mm. Ref. 3590

200 €

Soporte falso techo regulable 120 cm de 150 a 240 mm. Ref. 6760  
False ceiling support adjustable 120 cm from 150 to 340 mm. Ref. 6760

170 €

Soporte falso techo regulable 120 cm de 250 a 440 mm. Ref. 6761  
False ceiling support adjustable 120 cm from 250 to 440 mm. Ref. 6761

200 €

### Front 90 cm

Juego de tubos hasta altura total de 1500 mm  
Set of chimneys to a total height of 1500 mm  
(Indicar la medida en su pedido) - (Indicate the size in your order)

250 €

Juego de tubos hasta altura total de entre 1501 y 2000 mm  
Set of flue pipes to a total height of between 1501 and 2000 mm  
(Indicar la medida en su pedido) - (Indicate the size in your order)

345 €

### Front 120 cm

Juego de tubos + estructura hasta altura total de 1500 mm  
Set of flue pipes to a total height of 1500 mm  
(Indicar la medida en su pedido) - (Indicate the size in your order)

550 €

Juego de tubos + estructura hasta altura total de entre 1501 y 2000 mm  
Set of flue pipes to a total height of between 1501 and 2000 mm  
(Indicar la medida en su pedido) - (Indicate the size in your order)

595 €

## Notas / Notes

### AirClean

Sistema automático de funcionamiento del motor 10 min. cada hora durante 5 horas.  
Automatic working motor system for 10 minutes every hour during 5 hours.

Medida 90: Apta para encimeras compactas de 60 o 70 cm de ancho.  
Size 90: Recommended for hobs 60 or 70 cm wide.

Medida 120: Apta para encimeras compactas de hasta 90 cm de ancho.  
Size 120: Recommended for hobs up to 90 cm wide.

Incorpora exclusivamente opción de recirculación mediante difusor a techo con filtro cerámico.

It exclusively incorporates the recirculation option by means of ceiling diffuser with ceramic filter.



Acceso / Acces WEB



## Esquemas medidas / Technical Drawings

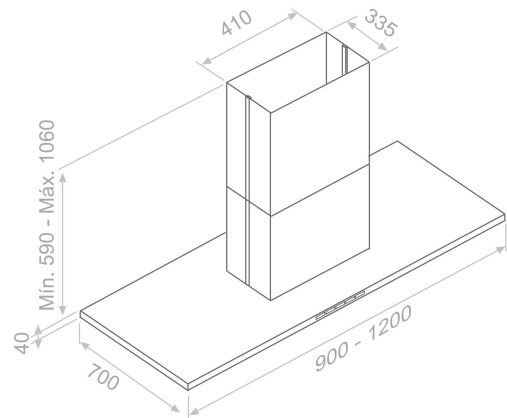

### Tubos especiales a medida / Special custom-made chimneys

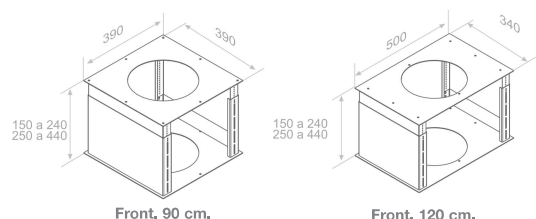

Front. 90 cm.

Front. 120 cm.

Soporte falso techo regulable / Adjustable false ceiling support



Model. 90 cm



Isia / Island



**I-402**



# I-825

Inox - Negro  
Stainless Steel - Black

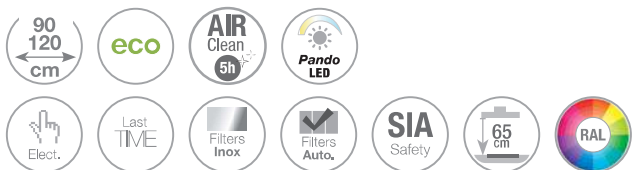

Modelos / Models

## S.E.C. System® Motor Interior / Interior Motor

Front. (cm)	Motor	Ø tubo	Clas. Ener.	Ref.	P.V.R
<b>Inox / Stainless Steel</b>					
90	V.850	Ø150	A	007602	1.195 €
	V.1250 eco	Ø150	A+	008442	1.595 €
120	V.1250 eco	Ø150	A+	009021	1.795 €
<b>Negro / Black</b>					
90	V.850	Ø150	A	010111	1.295 €
	V.1250 eco	Ø150	A+	010112	1.695 €
120	V.1250 eco	Ø150	A+	010113	1.895 €

Opcionales / Options

### AirLink

Modelo compatible. Es imprescindible solicitar esta opción en el pedido de la campana. No se equipa de serie. 0 €  
Compatible Model. This option must be requested together with the purchase order. Is not included as standard.

Kits de recirculación. Ver página 210. Activated carbon filters kit. See page 210

Mando a distancia Touch. Suministrado con la campana. 120 €  
Remote Control Touch supplied together with the hood.

Soporte falso techo regulable de 150 a 240 mm. Ref. 3589. 170 €  
False ceiling support adjustable from 150 to 240 mm. Ref. 3589

Soporte falso techo regulable de 250 a 440 mm. Ref. 3590. 200 €  
False ceiling support adjustable from 250 to 440 mm. Ref. 3590

Juego de tubos INOX hasta altura total de 1500 mm. 250 €  
Stainless steel chimney set to a total height of 1500 mm  
(Indicar la medida en su pedido) - (Indicate the size in your order)

Juego de tubos INOX hasta altura total de entre 1501 y 2000 mm. 345 €  
Stainless steel chimney set to a total height of between 1501 and 2000 mm  
(Indicar la medida en su pedido) - (Indicate the size in your order)

Juego de tubos NEGRO SATINADO hasta altura total de 1500 mm. 470 €  
WHITE chimney set to a total height of 1500 mm  
(Indicar la medida en su pedido) - (Indicate the size in your order)

Juego de tubos NEGRO SATINADO hasta altura total de entre 1501 y 2000 mm. 565 €  
WHITE chimney set to a total height of between 1501 and 2000 mm  
(Indicar la medida en su pedido) - (Indicate the size in your order)

Notas / Notes

### AirClean

Sistema automático de funcionamiento del motor 10 min. cada hora durante 5 horas.  
Automatic working motor system for 10 minutes every hour during 5 hours.

Esquemas medidas / Technical Drawings

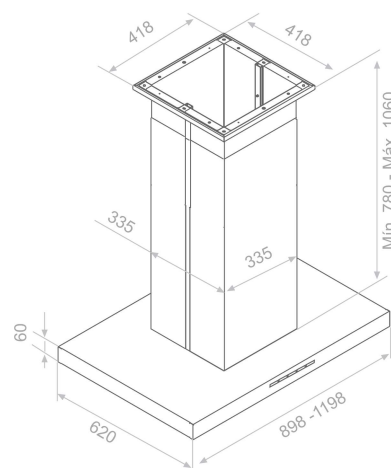

Tubos especiales a medida / Special custom-made chimneys

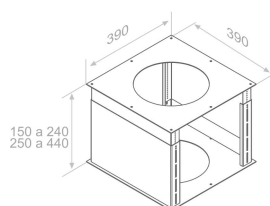

Soporte falso techo regulable  
Adjustable false ceiling support



Acceso / Acces WEB

Model. 90 cm



Isla / Island



**I-825**

# I-826

Inox-Cristal Negro  
Stainless Steel-Black Glass



Modelos / Models

## S.E.C. System® Motor Interior / Interior Motor

Front. (cm)	Motor	Ø tubo	Clas. Ener.	Ref.	P.V.R
90	V.850	Ø150	A	009474	1.395 €
	V.1250 eco	Ø150	A+	009475	1.795 €



Isia / Island

Opcionales / Options

### AirLink

Modelo compatible. Es imprescindible solicitar esta opción en el pedido de la campana. No se equipa de serie  
Compatible Model. This option must be requested together with the purchase order.  
Is not included as standard.

Kits de recirculación. Ver página 210  
Activated carbon filters kit. See page 210

Mando a distancia Touch. Suministrado con la campana.  
Remote Control Touch supplied together with the hood. 120 €

Soporte falso techo regulable de 150 a 240 mm. Ref. 3589  
False ceiling support adjustable from 150 to 240 mm. Ref. 3589 170 €

Soporte falso techo regulable de 250 a 440 mm. Ref. 3590  
False ceiling support adjustable from 250 to 440 mm. Ref. 3590 200 €

Juego de tubos hasta altura total de 1500 mm  
Set of chimneys to a total height of 1500 mm  
(Indicar la medida en su pedido) - (Indicate the size in your order) 250 €

Juego de tubos hasta altura total de entre 1501 y 2000 mm  
Set of chimneys to a total height of between 1501 and 2000 mm  
(Indicar la medida en su pedido) - (Indicate the size in your order) 345 €

Notas / Notes

### AirClean

Sistema automático de funcionamiento del motor 10 min. cada hora durante 5 horas.  
Automatic working motor system for 10 minutes every hour during 5 hours.

Esquemas medidas / Technical Drawings

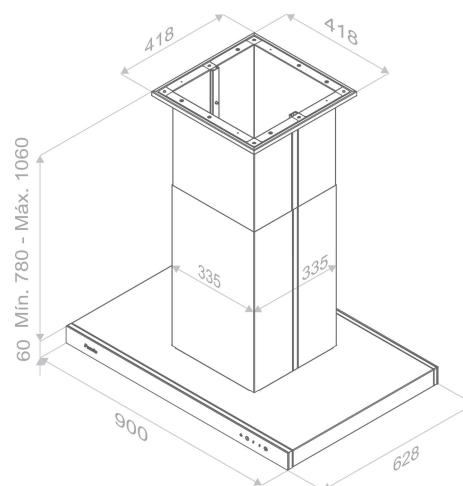

Tubos especiales a medida / Special custom-made chimneys



Acceso / Acces WEB



Isla / Island



I-826



# I-861

Inox - Esmaltado Negro  
Stainless Steel - Black enamel



Modelos / Models

## Inox / Stainless Steel

### S.E.C. System® Motor Interior / Interior Motor

Front. (cm)	Motor	Ø tubo	Clas. Ener.	Ref.	P.V.R
90	V.1250 eco	Ø150	A+	008920	2.395 €
120	V.1250 eco	Ø150	A+	008928	2.695 €

### Intermedio exterior / Duct-in-line

90	V.1550 eco	Ø150	A+	009477	2.795 €
	V.2450 eco	Ø200	A+	009479	3.195 €
120	V.1550 eco	Ø150	A	009482	3.095 €
	V.2450 eco	Ø200	A	009484	3.595 €

### De tejado / Remote: Roof Outdoor

90	V.2350 eco	Ø200	A+	009480	3.295 €
120	V.2350 eco	Ø200	A	009485	3.695 €

Modelos / Models

## Negro satinado / Satin black

### S.E.C. System® Motor Interior / Interior Motor

Front. (cm)	Motor	Ø tubo	Clas. Ener.	Ref.	P.V.R
90	V.1250 eco	Ø150	A+	010405	2.795 €
120	V.1250 eco	Ø150	A+	010409	3.095 €

### Intermedio exterior / Duct-in-line

90	V.1550 eco	Ø150	A+	010406	3.195 €
	V.2450 eco	Ø200	A+	010407	3.595 €
120	V.1550 eco	Ø150	A	010410	3.495 €
	V.2450 eco	Ø200	A	010411	3.995 €

### De tejado / Remote: Roof Outdoor

90	V.2350 eco	Ø200	A+	010408	3.695 €
120	V.2350 eco	Ø200	A	010412	4.095 €

Isia / Island

Opcionales / Options

### AirLink

Modelo compatible. Es imprescindible solicitar esta opción en el pedido de la campana. No se equipa de serie.  
Compatible Model. This option must be requested together with the purchase order. Is not included as standard.

0 €

Kits de recirculación. Ver página 210  
Activated carbon filters kit. See page 210

Mando a distancia Touch. Suministrado con la campana.  
Remote Control Touch supplied together with the hood.

120 €

Soporte falso techo regulable de 150 a 240 mm. Ref. 3589  
False ceiling support adjustable from 150 to 240 mm. Ref. 3589

170 €

Soporte falso techo regulable de 250 a 440 mm. Ref. 3590  
False ceiling support adjustable from 250 to 440 mm. Ref. 3590

200 €

Juego de tubos INOX hasta altura total de 1500 mm  
Stainless steel chimney set to a total height of 1500 mm  
(Indicar la medida en su pedido) - (Indicate the size in your order)

180 €

Juego de tubos INOX hasta altura total de entre 1501 y 2000 mm  
Stainless steel chimney set to a total height of between 1501 and 2000 mm  
(Indicar la medida en su pedido) - (Indicate the size in your order)

220 €

Juego de tubos NEGRO SATINADO hasta altura total de 1500 mm  
BLACK chimney set to a total height of 1500 mm  
(Indicar la medida en su pedido) - (Indicate the size in your order)

290 €

Juego de tubos NEGRO SATINADO hasta altura total de entre 1501 y 2000 mm  
BLACK chimney set to a total height of between 1501 and 2000 mm  
(Indicar la medida en su pedido) - (Indicate the size in your order)

375 €

Notas / Notes

### AirClean

Sistema automático de funcionamiento del motor 10 min. cada hora durante 5 horas.  
Automatic working motor system for 10 minutes every hour during 5 hours.

Consultar otras medidas disponibles, precio y plazo de entrega.  
See other sizes available, price and delivery time.

Sistema BOP en todas las medidas.  
BOP system in all sizes

### Bajo presupuesto / On request

Modelo personalizable en cualquier color de la carta RAL.  
Customizable model in any color from the RAL chart

Esquemas medidas / Technical Drawings

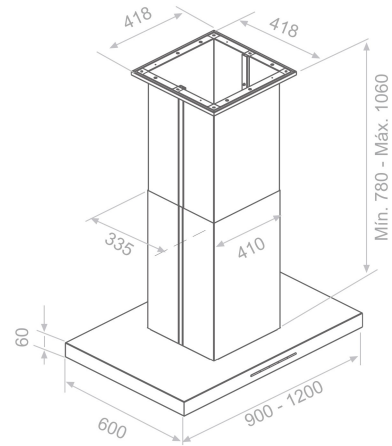

Tubos especiales a medida / Special custom-made chimneys



Acceso / Acces WEB

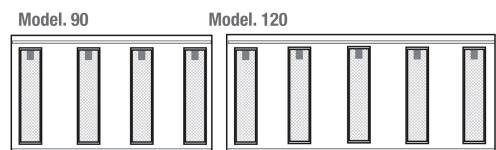

Ejemplo distribución de la bandeja inferior. Para campanas de otras medidas consultar distribución de la bandeja inferior.  
Sample bottom tray layout. For hoods in other sizes, consult bottom tray layout.



Isla / Island



**I-861**

# I-875

Acero inoxidable esmaltado en negro o carta RAL.  
 Colección especial en color negro.  
 Enamel Stainless Steel from RAL color Chart.  
 Special collection in black color



**Modelo exclusivo de recirculación**  
**Exclusive recirculation model**

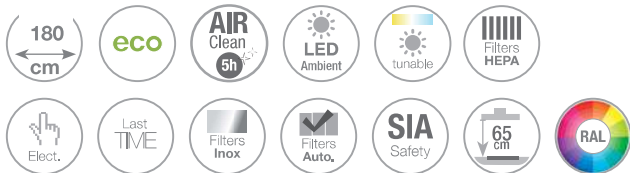

Modelos / Models

**S.E.C. System®**  
**Motor Interior / Interior Motor**

Front. (cm)	Motor	Ø tubo	Clas. Ener.	Ref.	P.V.R
180	V.1130 eco PLUS	Ø150	A	010413	2.495 €* Price black satin colour*



**Campana totalmente personalizable tanto en color como en la medida del frontal**  
**Fully customizable Cooker Hood in both color and in the size of the front**



Isia / Island

Opcionales / Options

**AirLink**

Modelo compatible. Es imprescindible solicitar esta opción en el pedido de la campana. No se equipa de serie. 0 €  
 Compatible Model. This option must be requested together with the purchase order. Is not included as standard.

Mando a distancia Touch. Suministrado con la campana. 120 €  
 Remote Control Touch supplied together with the hood.

Kits de recirculación. Bajo presupuesto  
 Activated carbon filters kit. On request

Notas / Notes

**AirClean**

Sistema automático de funcionamiento del motor 10 min. cada hora durante 5 horas.  
 Automatic working motor system for 10 minutes every hour during 5 hours.

**Bajo presupuesto / On request**

Modelo personalizable en cualquier color de la carta RAL.  
 Customizable model in any color from the RAL chart

Medidas especiales bajo estudio.  
 Special sizes on request.

Esquemas medidas / Technical Drawings

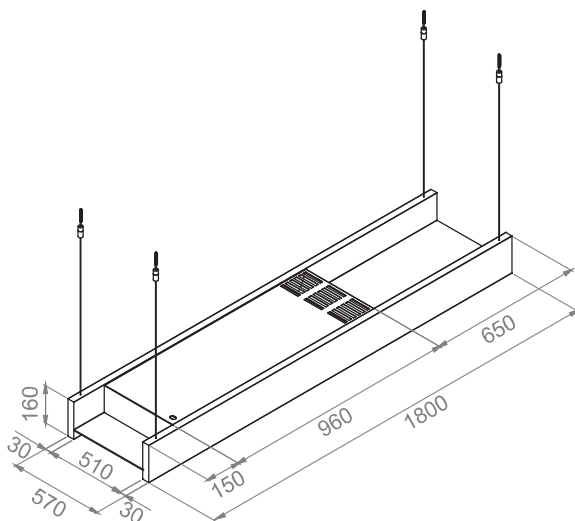

Acceso / Acces WEB





Isla / Island



I-875



# I-897

## CRISTAL GLASS

Inox esmaltado con color de la carta RAL  
 Colección especial en color negro  
 Enamel Stainless Steel from RAL color Chart.  
 Special collection in black color

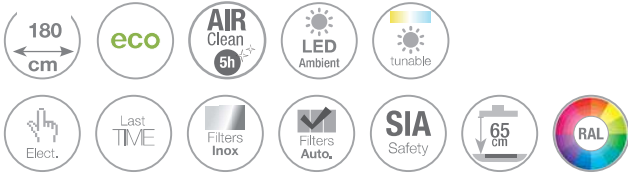

### Modelos / Models

#### S.E.C. System® Interior / Interior

Motor	Ø tubo
V.1250 eco	Ø150

#### Intermedio exterior / Duct-in-line motor

V.1550 eco	Ø150
V.2450 eco	Ø200
V.3000 eco	Ø200

#### De tejado / Remote motor -Roof Outdoor

V.2350 eco	Ø200
V.3300 eco	Ø200

Negro mate RAL 9005  
 Black mat RAL 9005



Negro satinado  
 Black satin



Negro texturado  
 Textured black



Isia / Island

### Opcionales / Options

#### AirLink

Modelo compatible. Es imprescindible solicitar esta opción en el pedido de la campana. No se equipa de serie  
 Compatible Model. This option must be requested together with the purchase order.  
 Is not included as standard. 0 €

Kits de recirculación. Bajo presupuesto  
 Activated carbon filters kit. On request

Mando a distancia Touch. Suministrado con la campana.  
 Remote Control Touch supplied together with the hood. 120 €

Soporte a falso techo ajustable de 150 a 240 mm. Ref. 6760  
 Adjustable False ceiling Telescopic Support set 170 €

Soporte a falso techo ajustable de 250 a 440 mm. Ref. 6761  
 Adjustable False ceiling Telescopic Support set 200 €

### Notas / Notes

#### AirClean

Sistema automático de funcionamiento del motor 10 min. cada hora durante 5 horas.  
 Automatic working motor system for 10 minutes every hour during 5 hours.

#### Bajo presupuesto / On request

Modelo personalizable en cualquier color de la carta RAL  
 Customizable model in any color from the RAL chart

Medidas especiales bajo estudio.  
 Special sizes on request.

Enchufes y conectores USB.  
 Plugs and USB connectors.



### Esquemas medidas / Technical Drawings

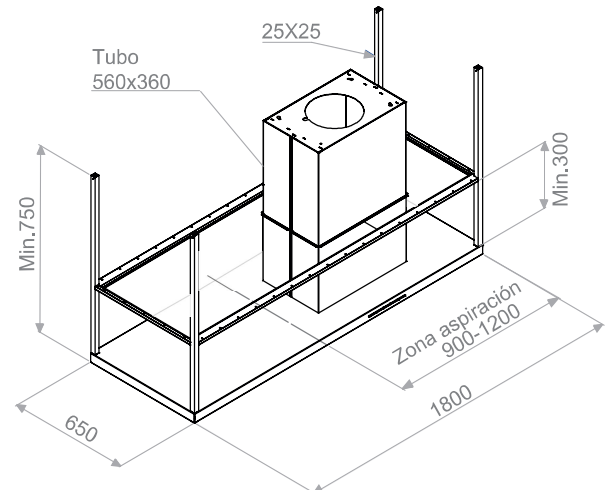

Soporte falso techo regulable  
 Adjustable false ceiling support  
 150 a 240 mm. Ref. 006760  
 250 a 440 mm. Ref. 006761

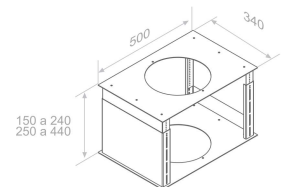

Acceso / Acces WEB



Isia / Island



ZONA FILTRANTE TOTAL BLACK  
TOTAL BLACK FILTER ZONE

**I-897**  
CRISTAL  
GLASS

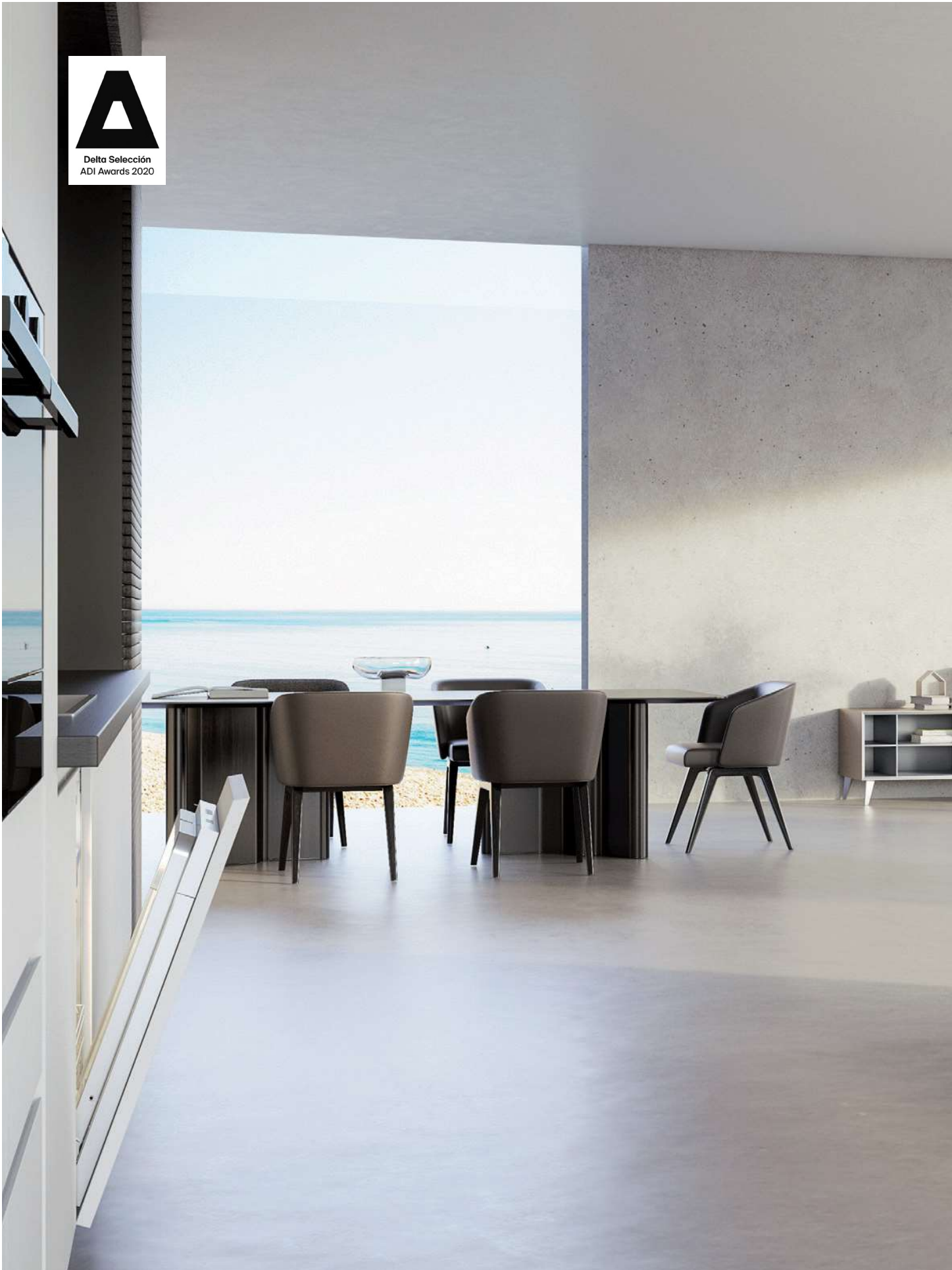





**I-898**



# I-898

Inox esmaltado con color de la carta RAL  
 Colección especial en color negro  
 Opción de 1 o 2 racks

Enamel Stainless Steel from RAL color Chart.  
 Special collection in black color  
 Option 1 or 2 racks



Delta Selección  
 ADI Awards 2020



Modelos / Models

### S.E.C. System® Interior / Interior

Motor	Ø tubo
V.1250 <i>eco</i>	Ø150
V.2200 <i>eco</i>	Ø200
<b>Intermedio exterior / Duct-in-line motor</b>	
V.1550 <i>eco</i>	Ø150
V.2450 <i>eco</i>	Ø200
V.3000 <i>eco</i>	Ø200
<b>De tejado / Remote motor -Roof Outdoor</b>	
V.2350 <i>eco</i>	Ø200
V.3300 <i>eco</i>	Ø200



Negro mate RAL 9005  
 Black mat RAL 9005

Negro satinado  
 Black satin

Negro texturado  
 Textured black

Opcionales / Options

### AirLink

Modelo compatible. Es imprescindible solicitar esta opción en el pedido de la campana. No se equipa de serie. 0 €  
 Compatible Model. This option must be requested together with the purchase order. Is not included as standard.

Mando a distancia Touch. Suministrado con la campana. 120 €  
 Remote Control Touch supplied together with the hood.

Soporte a falso techo ajustable 170 €  
 Adjustable False ceiling Telescopic Support set de 150 a 240 mm. Ref. 6760

Soporte a falso techo ajustable 200 €  
 Adjustable False ceiling Telescopic Support set de 250 a 440 mm. Ref. 6761

Notas / Notes

### AirClean

Sistema automático de funcionamiento del motor 10 min. cada hora durante 5 horas.  
 Automatic working motor system for 10 minutes every hour during 5 hours.

### Bajo presupuesto / On request

Modelo personalizable en cualquier color de la carta RAL.  
 Customizable model in any color from the RAL chart

Enchufes y conectores USB.  
 Plugs and USB connectors.



Esquemas medidas / Technical Drawings

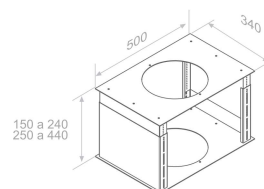
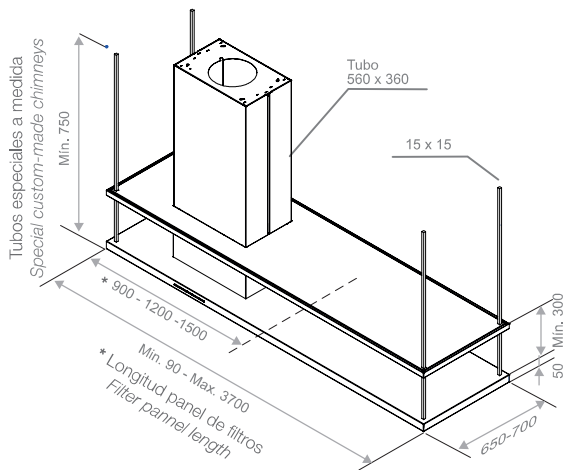
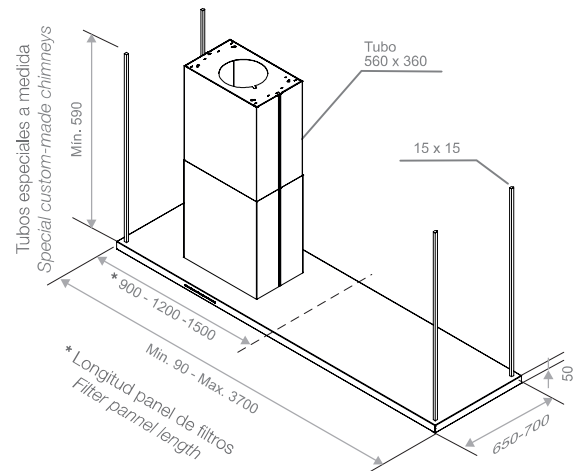

**Soporte falso techo regulable**  
 Adjustable false ceiling support  
 150 a 240 mm. Ref. 006760  
 250 a 440 mm. Ref. 006761



Acceso / Acces WEB

Acceso a esquemas para confirmar las medidas.  
 Access to the scheme to confirm hood dimension details.



Isla / Island

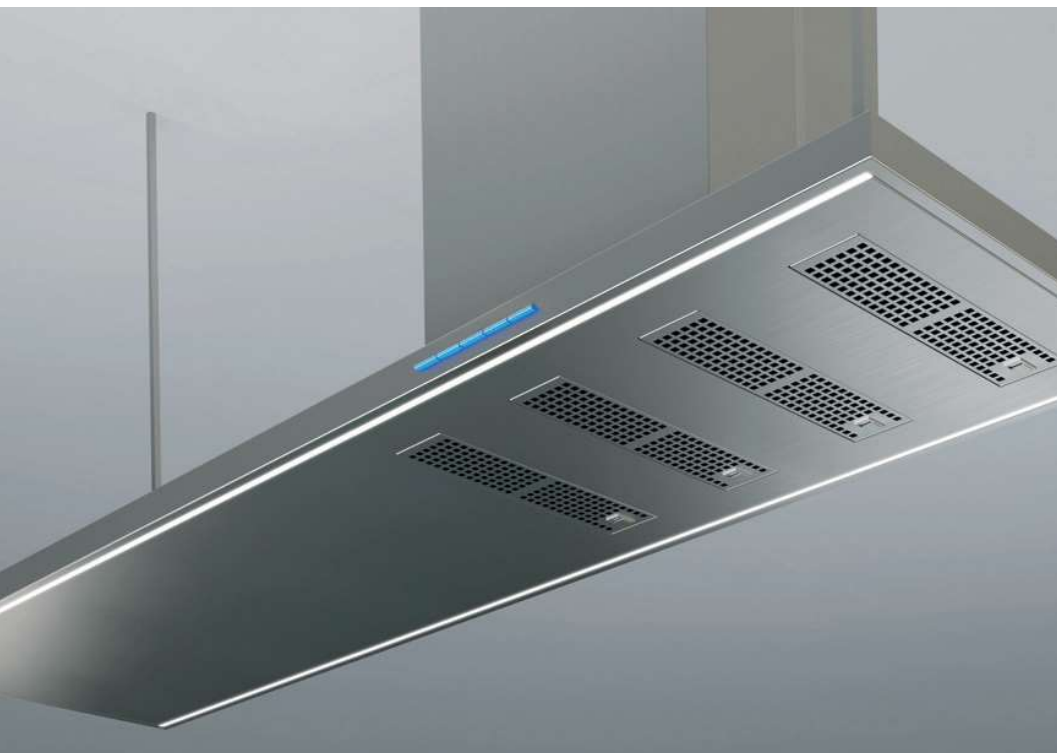

**I-898**

# I-960

Inox  
Cristal blanco óptico o cristal negro  
Stainless Steel  
Optical white glass or black glass



Modelos / Models

## Inox / Stainless Steel

### S.E.C. System® Motor Interior / Interior Motor

Front. (cm)	Motor	Ø tubo	Clas. Ener.	Ref.	P.V.R
100	V.1250 eco	Ø150	A+	009518	1.995 €

### Intermedio exterior / Duct-in-line motor

100	V.1550 eco	Ø150	A+	009519	2.395 €
-----	------------	------	----	--------	---------

## Cristal negro / Black glass

### S.E.C. System® Motor Interior / Interior Motor

100	V.1250 eco	Ø150	A+	009522	2.395 €
-----	------------	------	----	--------	---------

### Intermedio exterior / Duct-in-line motor

100	V.1550 eco	Ø150	A+	009523	2.795 €
-----	------------	------	----	--------	---------

## Cristal blanco óptico / Optical white glass

### S.E.C. System® Motor Interior / Interior Motor

100	V.1250 eco	Ø150	A+	009520	2.395 €
-----	------------	------	----	--------	---------

### Intermedio exterior / Duct-in-line motor

100	V.1550 eco	Ø150	A+	009521	2.795 €
-----	------------	------	----	--------	---------

Opcionales / Options

### AirLink

Modelo compatible. Es imprescindible solicitar esta opción en el pedido de la campana. No se equipa de serie  
Compatible Model. This option must be requested together with the purchase order. Is not included as standard.

0 €

Kits de recirculación. Ver página 210  
Activated carbon filters kit. See page 210

Mando a distancia Touch. Suministrado con la campana.  
Remote Control Touch supplied together with the hood.

120 €

Embellecedor a techo. Ref. 7116  
Ceiling trim. Ref. 7116.

160 €

SopORTE falso techo regulable de 150 a 240 mm. Ref. 7972  
False ceiling support adjustable from 150 to 240 mm. Ref. 7972

170 €

SopORTE falso techo regulable de 250 a 440 mm. Ref. 7973  
False ceiling support adjustable from 250 to 440 mm. Ref. 7973

200 €

Juego de tubos hasta altura total de 1500 mm  
Set of chimneys to a total height of 1500 mm  
(Indicar la medida en su pedido) - (Indicate the size in your order)

550 €

Juego de tubos hasta altura total de entre 1501 y 2000 mm  
Set of chimneys to a total height of between 1501 and 2000 mm  
(Indicar la medida en su pedido) - (Indicate the size in your order)

595 €

Notas / Notes

### AirClean

Sistema automático de funcionamiento del motor 10 min. cada hora durante 5 horas.  
Automatic working motor system for 10 minutes every hour during 5 hours.

Apto sólo para encimeras de máximo 900 x 350 mm.  
Recommended only for hobs of a maximum of 900 x 350 mm



Esquemas medidas / Technical Drawings

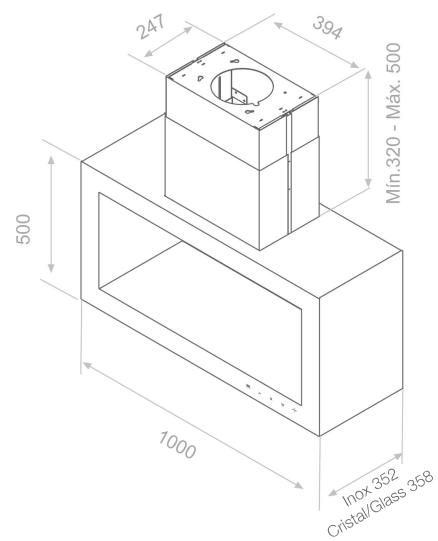

### Tubos especiales a medida / Special custom-made chimneys

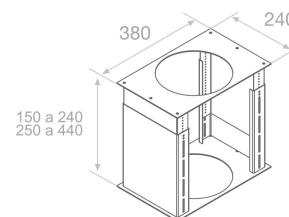

### SopORTE falso techo regulable / Adjustable false ceiling support



Acceso / Acces WEB



**I-960**



# I-1001 Inox

## Stainless Steel

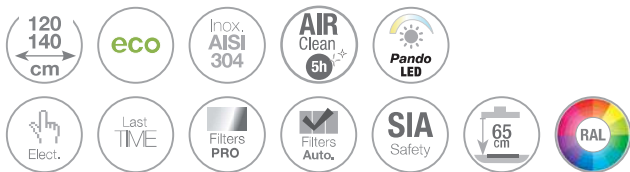

Modelos / Models

### Interior / Interior

Front. (cm)	Motor	Ø tubo	Clas. Ener.	Ref.	P.V.R
120	V.1250 eco	Ø150	A+	008550	2.995 €
	V.2200 eco	Ø200	A	010243	4.495 €
140	V.1250 eco	Ø150	A+	008558	3.395 €
	V.2200 eco	Ø200	A	010244	4.895 €

### Intermedio exterior / Duct-in-line

120	V.1550 eco	Ø200	A+	009524	3.395 €
	V.2450 eco	Ø200	A+	009526	3.895 €
140	V.2450 eco	Ø200	A+	009530	4.195 €

### De tejado / Remote: Roof Outdoor

120	V.2350 eco	Ø200	A+	009527	3.995 €
140	V.2350 eco	Ø200	A+	009531	4.295 €

Opcionales / Options

### AirLink

Modelo compatible. Es imprescindible solicitar esta opción en el pedido de la campana. No se equipa de serie  
Compatible Model. This option must be requested together with the purchase order. Is not included as standard.

Embellecedor a techo. Ref. 7116  
Ceiling trim. Ref. 7116. 160 €

Mando a distancia Touch. Suministrado con la campana.  
Remote Control Touch supplied together with the hood. 120 €

SopORTE falso techo regulable de 150 a 240 mm. Ref. 6760  
False ceiling support adjustable from 150 to 240 mm. Ref. 6760 170 €

SopORTE falso techo regulable de 250 a 440 mm. Ref. 6761  
False ceiling support adjustable from 250 to 440 mm. Ref. 6761 200 €

Juego de tubos hasta altura total de 1500 mm  
Set of chimneys to a total height of 1500 mm  
(Indicar la medida en su pedido) - (Indicate the size in your order) 550 €

Juego de tubos hasta altura total de entre 1501 y 2000 mm  
Set of chimneys to a total height of between 1501 and 2000 mm  
(Indicar la medida en su pedido) - (Indicate the size in your order) 595 €

Notas / Notes

Incorpora exclusivamente opción de recirculación mediante difusor a techo con filtro cerámico.  
It exclusively incorporates the recirculation option by means of ceiling diffuser with ceramic filter.

Incorpora bandeja de fácil limpieza que recoge aceite de los filtros.  
Includes easy-cleaning tray for collection of oil.

### Bajo presupuesto / On request

Modelo personalizable en cualquier color de la carta RAL  
Customizable model in any color from the RAL chart

Esquemas medidas / Technical Drawings

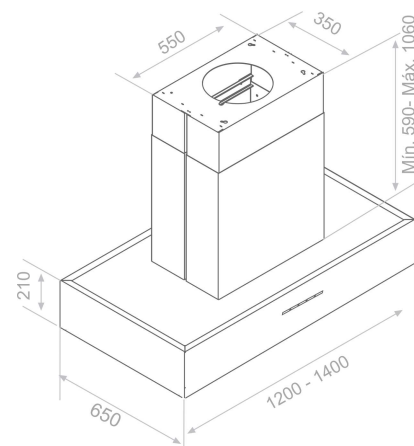

Opcional a medida.  
Can be custom made.

Tubos especiales a medida / Special custom-made chimneys

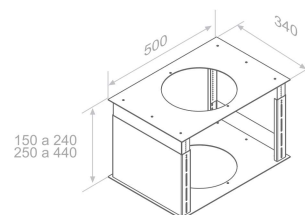

SopORTE falso techo regulable / Adjustable false ceiling support



Acceso / Acces WEB



Isla / Island



**I-1001**

# I-1300

Inox - A medida  
Stainless Steel - Custom made



## Modelos / Models

### S.E.C. System® Motor Interior / Interior Motor

Front. (cm)	Motor	Ø tubo	Clas. Ener.	Ref.	P.V.R
Ø45	V.850	Ø150	A		4.950 € desde from

## Opcionales / Options

### AirLink

Modelo compatible. Es imprescindible solicitar esta opción en el pedido de la campana. No se equipa de serie 0 €  
Compatible Model. This option must be requested together with the purchase order. Is not included as standard.

Kits de recirculación. Ver página 210 0 €  
Activated carbon filters kit. See page 210

Deflector de aire para modelos de reciclaje (FCLR-AE) 0 €  
Air diffuser for recirculation models (FCLR-AE)

Opción de cambio de LED original a LED de 3000K. Suministrado con la campana. 0 €  
LED change to warm light LED 3000K. Available only at the factory

Soporte falso techo regulable de medida 90 de 250 a 440 mm. Ref. 7282 200 €  
False ceiling support adjustable size 90 from 250 to 440 mm. Ref. 7282

## Notas / Notes

Campana realizada a medida en cuanto a altura..  
Hood custom-made based on height.

### Bajo presupuesto / On request

Modelo personalizable en cualquier color de la carta RAL.  
Customizable model in any color from the RAL chart

## Esquemas medidas / Technical Drawings



Acceso / Acces WEB

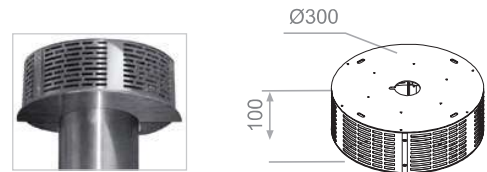

Deflector de aire para modelos de reciclaje (FCLR-AE)  
Air diffuser for recirculation models (FCLR-AE)

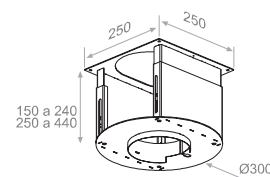

Soporte falso techo regulación de 150 a 240 mm. en rotación (incluido)  
False Ceiling Support adjustable from 150 to 240 mm. (included)

Soporte falso techo regulación de 250 a 440 mm. (opcional)  
False ceiling support adjustable from 250 to 440 mm (optional)



Lamas de aluminio lacadas personalizables en cualquier color de la carta RAL.  
Aluminium, lacquered fins, custom made in any RAL chart colour

**I-1300**



# SKYLOOP CERAMIC

Inox - Ceramic  
Stainless Steel - Ceramic

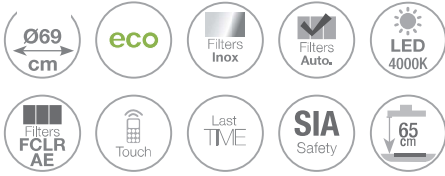

Modelos / Models

## S.E.C. System® Interior / Interior

Front. (cm)	Motor	Ø tubo	Ref.	P.V.R
<b>Blanc / White</b>				
Ø69	V.1130 eco	Ø150	009722	2.995 €
<b>Negro satinado / Satin black</b>				
Ø69	V.1130 eco	Ø150	009948	2.995 €
<b>Oro / Gold</b>				
Ø69	V.1130 eco	Ø150	009725	2.995 €
<b>Plata / Silver</b>				
Ø69	V.1130 eco	Ø150	009724	2.995 €
<b>Cobre / Copper</b>				
Ø69	V.1130 eco	Ø150	009723	2.995 €

Kit cables / kit cables

L: 2500 mm	500050400126	45 €
L: 4000 mm	500050400127	90 €



Isia / Island

Opcionales / Options

### AirLink

Modelo compatible. Es imprescindible solicitar esta opción en el pedido de la campana. No se equipa de serie  
Compatible Model. This option must be requested together with the purchase order. Is not included as standard.

Altura estándar del cable 1 metro. Alturas superiores solicitar en pedido  
Cable standard height of 1 metre. Heights exceeding this size on request

0 €

Notas / Notes

Cuerpo cerámico. Base Filtrante inferior en acero inoxidable  
Ceramic body. Stainless steel lower filtration base.

Iluminación circular LED 20W  
Circular lighting LED 20W

Iluminación LED sólo disponible en 4000K  
Lighting available only in LED 4000k

Solo disponible en sistema de filtros de carbón activado (recirculación).  
Available only in activated carbon filter system (recirculation).

Altura estándar del cable 1 metro.  
Cable standard height of 1 metre..

Esquemas medidas / Technical Drawings

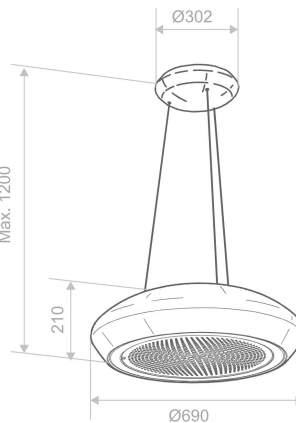

Acceso / Acces WEB

## LÁMPARA SKY LIGHT

Iluminación circular LED 85W / Circular lighting LED 85W



	Ref.	P.V.R
Blanco / White	009729	1.995 €
Negro satinado / Satin black	009983	1.995 €
Oro / Gold	009732	1.995 €
Plata / Silver	009731	1.995 €
Cobre / Copper	009730	1.995 €

Notas / Notes

Requiere conexión a la red eléctrica.  
Requires connection to main



Isla / Island



# SKYLOOP CERAMIC

# CAMPANAS DE TECHO

## CEILING COOKER HOODS









## Características y recomendaciones para las campanas de techo

Es esencial leer estas instrucciones, si elegimos para nuestro proyecto, la colocación de una campana de techo:

### ASEGURAMIENTO TÉCNICO GRATUITO:

Con el fin de certificar que su proyecto tendrá el éxito asegurado, **Pando** le recomienda explícitamente que nos haga llegar el Estudio Técnico de Proyectos para este fin.

Una vez analizado, podremos asegurarle la perfecta viabilidad de uso, con el modelo de campana de techo elegido.

### FORMA DEL TECHO:

El techo "ideal" para la colocación de estas unidades de campana, deberá ser completamente diáfano y liso en toda su superficie. Si por razones de diseño, se opta por realizar diferentes alturas o desniveles de techo, entonces debemos establecer que la zona donde este colocada la campana sea totalmente lisa y que tenga un perímetro lo más ancho posible, para evitar posibles pérdidas de aspiración (es necesario enviar plano para determinar si el techo periférico es el óptimo).

### ALTURA DE INSTALACIÓN A TECHO:

La distancia recomendada entre la encimera y la campana es de entre 1,40 m a 1,70 m. Para alturas superiores consultar a nuestra División Técnica.

### POSICIÓN DE LA CAMPANA:

La campana tiene que estar centrada con la zona de cocción.

### REJILLA DE ADMISIÓN DE AIRE:

Para asegurar un excelente funcionamiento de aspiración de la campana, es imprescindible que exista en la cocina una toma constante de entrada de aire; para ello puede servir perfectamente una rejilla de ventilación a ras de suelo.

### INSTALACION DE TUBO CONDUCTOR DE HUMO:

Es muy recomendable la utilización de tubos de extracción de humos S.E.C. System® de Pando, que mejoran considerablemente el confort de uso y la insonorización del equipo.

**INCLUIDO:** Todas las unidades con motorizaciones V.2450 y V.3000 Intermedio Exterior y V.2350 y V.3300 Tejado y V.2200 Interiores, incorporan de serie 5 m de tubo de extracción de humos S.E.C. System® de Ø interior 203 mm y Ø exterior 253 mm.

**INCLUIDO:** Todos los modelos incorporan de serie 2 m de tubo de extracción de humos espiral 150 circular.

## Features and recommendations for ceiling-mounted hoods.

It is very important to read the following instructions, if your project involves fitting a ceiling-mounted cooker hood:

### FREE-OF-CHARGE TECHNICAL CUSTOMER SERVICE:

Pando highly recommends you to send us back our "Technical viability form" duly filled in, prior to placing your order. Once our product experts have analyzed your proposal, they will provide you feedback and advice from technical point of view to ensure that your project will be a success and that product performance is optimal.

### FORM OF THE CEILING:

The "ideal" ceiling to install these hood units must be completely unobstructed and flat over all of its surface. If for design reasons you choose to have different heights or steps in the ceiling, it must be ensured that the area where the hood is to be fitted is completely flat and covers as wide an area as possible, to avoid any suction losses (you must send us a plan to determine whether the surrounding ceiling is suitable).

### CEILING HEIGHT:

Pando recommends that the distance between the cooking hob and the ceiling hood is between 140 and 170 cm. For greater heights consult our Technical Division.

### POSITION OF THE HOOD:

The hood must be centred over the cooking area.

### AIR INTAKE GRILLE:

To ensure optimal product performance and powerful suction of the hood, it is essential that the kitchen has a constant inflow of fresh air. A ventilation grille at plinth level is a perfect solution for this.

### INSTALLING OF THE FLUE PIPE:

Pando highly recommends to use our S.E.C. System® fume extractor flue pipes, as these are very easy to use and install, and clearly reduce the noise generation of the system.

**INCLUDED:** All units with V.2450 and V.3000 Exterior and V.2350 and V.3300 Roof motors and V.2200 Internal come with 5 m of S.E.C. System® fume extractor flue with interior Ø 203 mm and exterior Ø 253 mm as standard.

**INCLUDED:** All models comes with 2 m of 150 diameter circular spiral extractor flue as standard.

Puede descargar la hoja técnica en este enlace



Technical sheet available to download from this link



### Sistema de instalación con varillas roscadas.

Este es el sistema más tradicional para el montaje de las campanas de techo. Previamente debemos instalar las varillas al techo ajustando la altura deseada. La instalación es tan sencilla como introducir las varillas por los orificios.

### Installation System using rods.

This one is the most traditional fitting system for ceiling units. Just before lifting up the unit the rods must be fixed to the concrete adjusting the right height. Installation is as simple as introducing the rods through the hood side corner holes.



### Sistema de instalación con grapas directamente a falso techo

La zona de anclaje, se deberá reforzar previamente en relación al peso de la campana de techo a instalar.

### Fitting System using fixing metal clamps directly into the false ceiling

The gripping area previously needs to be reinforced based on ceiling hood weight to be installed.



**Box-motor giratorio** que permite el cambio de dirección de la salida del aire, facilitando de esta forma su instalación.

**Rotary motor-box** allowing airflow exit side change, and making fitting easier this way.



### Cambio del sentido de la apertura de la puerta inferior

Gracias a este sistema, podremos cambiar el sentido de apertura de la puerta inferior dependiendo de la orientación que nos sea más favorable en el momento de su instalación.

### Change on door opening direction

This system makes installation easier, as it allows us to adjust the door opening according to your specific needs on site.

## OPCIONAL / OPTIONAL:

### CONJUNTO DE BOTONERA PARA ENCASTRE A PARED

Ahora todas las campanas de techo pueden incorporar de forma opcional, una botonera de control de la campana encastrada a pared. El sistema incorpora de serie un cableado máximo de 10 m. Excepto la E-237

**Importante: El conjunto de botonera para encastrado a pared, solo se podrá servir junto al pedido de la campana de techo**

### BUTTON PANEL SET FOR EMBEDDING IN WALL

All ceiling-mounted hoods now optionally feature a control button panel for the hood embedded into the wall. The system comes with up to 10 m of cable as standard. Except E-237 models.

**Important: The panel set for embedding into the wall can be only ordered when the order is placed.**



Diámetro tubo pasacables mínimo 25 mm

The min. diameter of lead-through cable must be min. of 25 mm

P.V.R.

Modelo Inox / Stainless Steel	120 €
Modelo Blanco / White	150 €

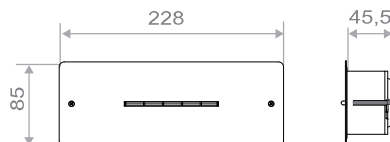

Medidas Encastrado  
Built in Sizes

220 x 75 x 50

# E-201 Esmaltado blanco Enameled white

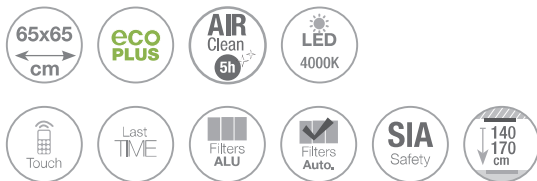

Modelos / Models

## S.E.C. System®

### Motor Interior / Interior Motor

Front. (cm)	Motor	Ø tubo	Clas. Ener.	Ref.	P.V.R
65	V.1130 eco PLUS	Ø150	B	010372	1.495 €

### Motor Intermedio exterior / Duct-in-line motor

65	V.1550 eco	Ø150	B	010374	2.195 €
----	------------	------	---	--------	---------

### Motor Exterior a muro / Remote motor - Wall Outdoor

65	V.1300 eco	Ø150	A	010373	2.195 €
----	------------	------	---	--------	---------

Opcionales / Options

## AirLink

Modelo compatible. Es imprescindible solicitar esta opción en el pedido de la campana. No se equipa de serie  
Compatible Model. This option must be requested together with the purchase order. Is not included as standard.

Kits de recirculación. Ver página 210  
Activated carbon filters kit. See page 210

Cambio a LED cálido de 3000K. Suministrado con la campana  
LED change to warm light LED 3000K. Available only at the factory

Este modelo puede solicitarse bajo pedido SIN ILUMINACIÓN.  
This model can be manufactured WITHOUT LIGHTING on request

Conjunto botonera INOX de encastre a pared.  
Solo suministrado con la campana  
Stainless steel button panel set for embedding into the wall.  
Available only at the factory

Conjunto botonera BLANCO de encastre a pared.  
Solo suministrado con la campana  
White enamel button panel set for embedding into the wall.  
Available only at the factory



Techo / Ceiling

Esquemas medidas / Technical Drawings

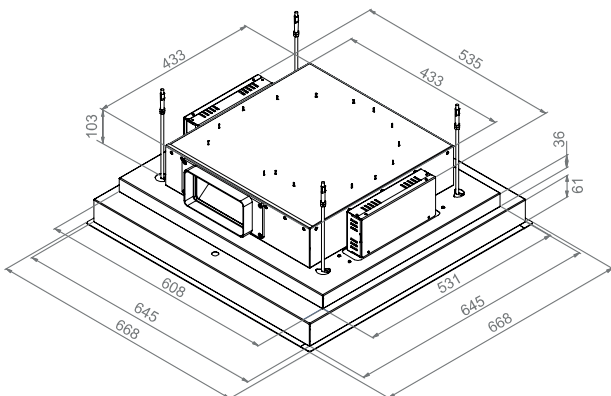

Altura mínima falso techo  
Minimum height of false ceiling

65 cm      205 mm

Medidas encastre  
Built in Sizes

65 cm      655 x 655 mm



Acceso / Acces WEB



Opcional / Options  
Inox / Stainless Steel  
Esmaltado blanco / White



**E-201**



# E-217 Esmaltado y cristal blanco

## Enameled and white glass



Modelos / Models

### S.E.C. System® Motor Interior / Interior Motor

Front. (cm)	Motor	Ø tubo	Clas. Ener.	Ref.	P.V.R
110	V.1130 eco PLUS	Ø150	A+	009690	1.895 €

Opcionales / Options

### AirLink

Modelo compatible. Es imprescindible solicitar esta opción en el pedido de la campana. No se equipa de serie  
Compatible Model. This option must be requested together with the purchase order. Is not included as standard.

0 €

Kits de recirculación. Ver página 210  
Activated carbon filters kit. See page 210

Conjunto botonera INOX de encastre a pared.  
Stainless steel button panel set for embedding into the wall.

Solo suministrado con la campana

120 €

Conjunto botonera BLANCO de encastre a pared.  
White enamel button panel set for embedding into the wall.

Solo suministrado con la campana

150 €

Available only at the factory.

Esquemas medidas / Technical Drawings



### Doble sistema de fácil instalación Double easy installation System

Ver pág. 119 / See page 119

Apertura de puerta / Door opening  
Box rotativo / Rotary Motor Box

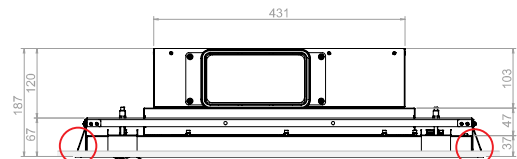

Grueso de la placa  
Thickness of the  
plasterboard  
20 mm max

VISTO POR A.  
A view

Altura mínima falso techo  
Minimum height of false ceiling

110 cm

195 mm

Medidas encastre  
Built in Sizes

110 cm

1065 x 670

Notas / Notes

Box-motor giratorio que permite el cambio de dirección de la salida del aire, facilitando de esta forma su instalación.  
Rotary motor-box allowing airflow exit side change, and making fitting easier this way.

Salida de humos de serie: lateral corto  
Standard fume outlet: short side



Para otras alturas, consultar con nuestra división técnica.  
For other heights, please check with our Technical department.



Opcional / Options  
Inox / Stainless Steel  
Esmaltado blanco / White

### INCLUIDO / INCLUDED

Este modelo incorpora de serie 2 m de tubo de extracción de humos espiral 150 circular  
This model comes with 2 m of 150 diameter circular spiral extractor flue as standard.

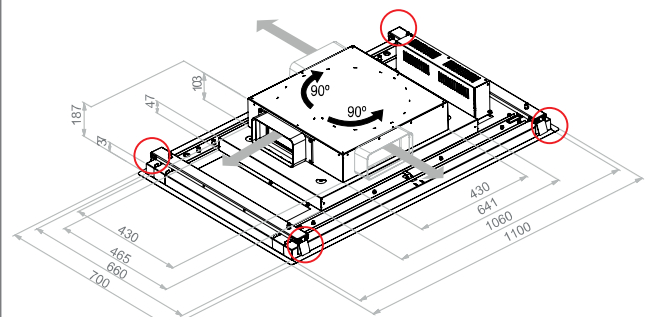

Peso / Weight: 30 kg



Acceso / Acces WEB



Proyecto Estudio DOCRYS & DC



**E-217**

Techo / Ceiling

# E-219

Esmaltado y cristal blanco  
White enamel and glass



Con sistema descendente que facilita la aspiración  
With descending system that facilitates aspiration



Modelos / Models

### S.E.C. System®

#### Motor Interior / Interior Motor

Front. (cm)	Motor	Ø tubo	Clas. Ener.	Ref.	P.V.R
90	V.1130 eco PLUS	Ø150	A+	010369	1.995 €

#### Motor Intermedio exterior / Duct-in-line motor

90	V.1200	Ø150	A	010370	1.995 €
----	--------	------	---	--------	---------



Techo / Ceiling

Opcionales / Options

### AirLink

Modelo compatible. Es imprescindible solicitar esta opción en el pedido de la campana. No se equipa de serie

Compatible Model. This option must be requested together with the purchase order. Is not included as standard.

0 €

Kits de recirculación. Ver página 210

Activated carbon filters kit. See page 210

Conjunto botonera INOX de encastre a pared.

Solo suministrado con la campana.

Stainless steel button panel set for embedding into the wall.

Available only at the factory.

120 €

Conjunto botonera BLANCO de encastre a pared.

Solo suministrado con la campana.

White enamel button panel set for embedding into the wall.

Available only at the factory.

150 €

Notas / Notes

Salida de humos de serie en motor intermedio y tejado: lateral corto

Standard fume outlet for duct-in-line and roof outdoor motors: short side



Para otras alturas, consultar con nuestra división técnica.

For other heights, please check with our Technical department.

Esquemas medidas / Technical Drawings

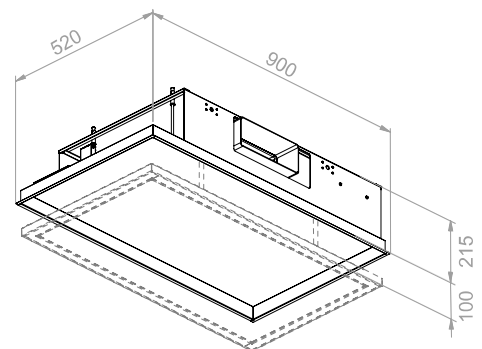

Altura mínima falso techo  
Minimum height of false ceiling

90 cm      220 mm

Medidas encastre  
Built in Sizes

90 cm      890 x 510



Opcional / Options  
Inox / Stainless Steel  
Esmaltado blanco / White



Acceso / Acces WEB



ASPIRATION OFF



ASPIRATION ON

**E-219**



# E-221

Inox - Esmaltado blanco epoxi RAL 9016 mate  
Stainless Steel - Epoxy white enamel RAL 9016 mat



## Modelos / Models

### S.E.C. System®

#### Motor Interior / Interior Motor

Front. (cm)	Motor	Ø tubo	Clas. Ener.	Ref.	P.V.R
<b>Inox / Stainless Steel</b>					
120	V.1130 eco PLUS	Ø150	A	009991.A	1.695 €
<b>Esmaltado blanco / Epoxy white enamel</b>					
120	V.1130 eco PLUS	Ø150	A	009992.A	1.895 €

## Opcionales / Options

### AirLink

Modelo compatible. Es imprescindible solicitar esta opción en el pedido de la campana. No se equipa de serie  
Compatible Model. This option must be requested together with the purchase order. Is not included as standard. 0 €

Kits de recirculación. Ver página 210  
Activated carbon filters kit. See page 210

Cambio a LED cálido de 3000K. Suministrado con la campana  
LED change to warm light LED 3000K. Available only at the factory 0 €

Este modelo puede solicitarse bajo pedido SIN ILUMINACIÓN.  
This model can be manufactured WITHOUT LIGHTING on request 60 €

Conjunto botonera INOX de encastre a pared.  
Solo suministrado con la campana.  
Stainless steel button panel set for embedding into the wall. 120 €  
Available only at the factory.

Conjunto botonera BLANCO de encastre a pared.  
Solo suministrado con la campana.  
White enamel button panel set for embedding into the wall. 150 €  
Available only at the factory.

## Notas / Notes

Box-motor giratorio que permite el cambio de dirección de la salida del aire, facilitando de esta forma su instalación.  
Rotary motor-box allowing airflow exit side change, and making fitting easier this way.

Para otras alturas, consultar con nuestra división técnica.  
For other heights, please check with our Technical department.



### Bajo presupuesto / On request

Modelo personalizable en cualquier color de la carta RAL  
Customizable model in any color from the RAL chart



Opcional / Options  
Inox / Stainless Steel  
Esmaltado blanco / White

### INCLUIDO / INCLUDED

Este modelo incorpora de serie 2 m de tubo de extracción de humos espiral 150 circular  
This model comes with 2 m of 150 diameter circular spiral extractor flue as standard.

## Esquemas medidas / Technical Drawings



### Doble sistema de fácil instalación Double easy installation System

Ver pág. 119 / See page 119

#### Apertura de puerta reversible / Reversible door opening Box rotativo / Rotary Motor Box

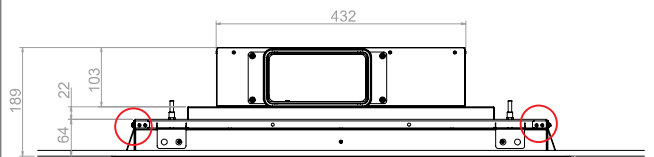

Vue de A  
A view

Grueso de la placa  
Thickness of the plasterboard  
10-35 mm max

Altura mínima falso techo Minimum height of false ceiling		Medidas encastre Built in Sizes	
120 cm	195 mm	120 cm	1130 x 725

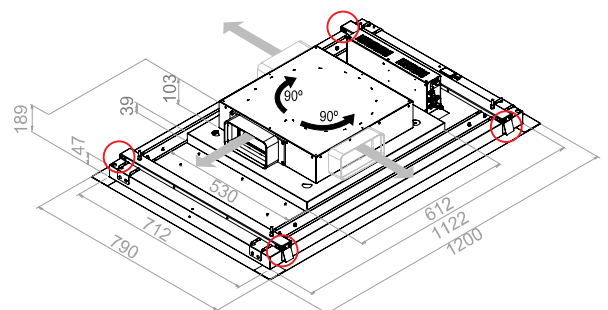

Peso / Weight: 40 kg



Acceso / Acces WEB



**E-221**







**E-231**  
**E-232**



# E-231 Esmaltado y cristal blanco

## White enamel and glass



Modelos / Models

### S.E.C. System®

#### Motor Interior / Interior Motor

Front. (cm)	Motor	Ø tubo	Clas. Ener.	Ref.	P.V.R
130	V.1130 eco PLUS	Ø150	A	009749	2.195 €

#### Motor Intermedio exterior / Duct-in-line motor

130	V.1550 eco	Ø150	A	009780	2.895 €
	V.2450 eco	Ø200	A	009781	3.195 €

#### Motor de tejado / Remote motor -Roof Outdoor

130	V.2350 eco	Ø200	A	009782	3.395 €
-----	------------	------	---	--------	---------

Opcionales / Options

### AirLink

Modelo compatible. Es imprescindible solicitar esta opción en el pedido de la campana. No se equipa de serie  
Compatible Model. This option must be requested together with the purchase order. Is not included as standard. 0 €

Kits de recirculación. Ver página 210  
Activated carbon filters kit. See page 210

Conjunto botonera INOX de encastre a pared.  
Solo suministrado con la campana.  
Stainless steel button panel set for embedding into the wall. 120 €  
Available only at the factory.

Conjunto botonera BLANCO de encastre a pared.  
Solo suministrado con la campana.  
White enamel button panel set for embedding into the wall. 150 €  
Available only at the factory.

Notas / Notes

Box-motor giratorio que permite el cambio de dirección de la salida del aire, facilitando de esta forma su instalación.  
Rotary motor-box allowing airflow exit side change, and making fitting easier this way.

Salida de humos de serie en motor intermedio y tejado: lateral corto  
Standard fume outlet for duct-in-line and roof outdoor motors: short side

Para otras alturas, consultar con nuestra división técnica.  
For other heights, please check with our Technical department.



Opcional / Options  
Inox / Stainless Steel  
Esmaltado blanco / White

### INCLUIDO / INCLUDED

Este modelo con motorización V.1130 ECO PLUS incorpora de serie 2 m de tubo de extracción de humos espiral Ø150 circular.  
This model with the V.1130 ECO PLUS motor system comes with 2 m of 150 diameter circular spiral extractor flue as standard.

Las unidades con motorizaciones V.2450 Intermedio Exterior y V.2350 Tejado, incorporan de serie 5 m de tubo de extracción de humos SEC System® de Ø203 mm interior y Ø253 mm exterior.  
This model with the V.2450 duct-in-line remote motor and V.2350 roof motor system comes with 5 m of S.E.C. fume extractor flue as standard System®, interior Ø 203 mm and exterior Ø 253.



### Doble sistema de fácil instalación

#### Double easy installation System

Ver pág. 119 / See page 119

Esquemas medidas / Technical Drawings

#### Motor Interior / Interior Motor

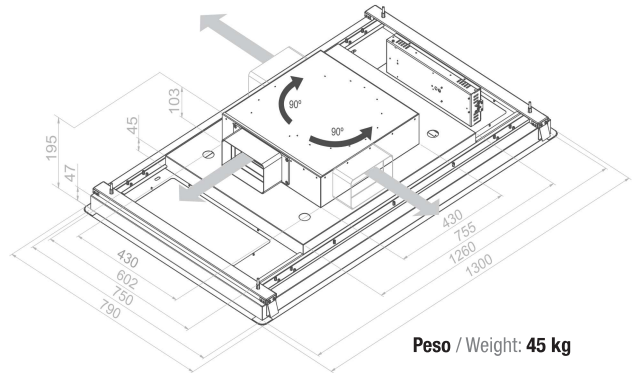

Peso / Weight: 45 kg

#### Apertura de puerta / Door opening

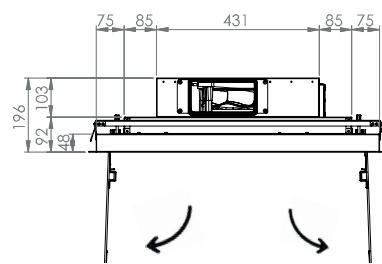

Vista de A  
A view

Grueso de la placa  
Thickness of the  
plasterboard  
20 mm max

Altura mínima falso techo  
Minimum height of false ceiling

Motor Int	200 mm	Medidas encastre Built in Sizes	
Motor Ext Ø 200	300 mm		
Motor Ext  260 x 100	200 mm	130	1268 x 763

#### Motor Intermedio exterior / Duct-in-line motor

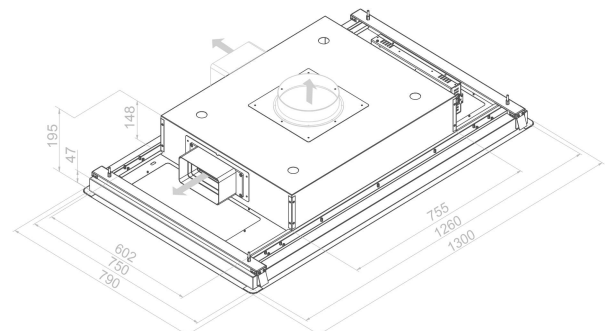

#### Apertura de puerta / Door opening

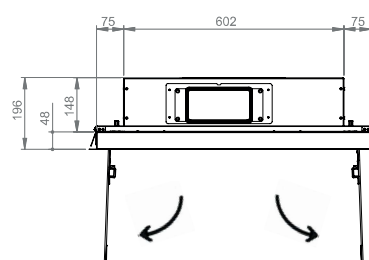

Acceso / Acces WEB

Techo / Ceiling

# E-232

Esmaltado y cristal blanco  
White enamel and glass



Modelos / Models

## S.E.C. System® Motor Interior / Interior Motor

Front. (cm)	Motor	Ø tubo	Clas. Ener.	Ref.	P.V.R
130	V.1250 eco	Ø150	A+++	009927	2.295 €

Opcionales / Options

### AirLink

Modelo compatible. Es imprescindible solicitar esta opción en el pedido de la campana. No se equipa de serie. 0 €  
Compatible Model. This option must be requested together with the purchase order. Is not included as standard.

Kits de recirculación. Ver página 210  
Activated carbon filters kit. See page 210

Conjunto botonera INOX de encastre a pared. Solo suministrado con la campana. 120 €  
Stainless steel button panel set for embedding into the wall. Available only at the factory.

Conjunto botonera BLANCO de encastre a pared. Solo suministrado con la campana. 150 €  
White enamel button panel set for embedding into the wall. Available only at the factory.

Notas / Notes

### AirClean

Sistema automático de funcionamiento del motor 10 min. cada hora durante 5 horas. Automatic working motor system for 10 minutes every hour during 5 hours.

Salida de humos de serie: Lateral largo, lateral corto o techo. Indicar en pedido Standard fume outlet option: long side, short side or ceiling, to be specified on order



Para otras alturas, consultar con nuestra división técnica.  
For other heights, please check with our Technical department.



Opcional / Options  
Inox / Stainless Steel  
Esmaltado blanco / White

Esquemas medidas / Technical Drawings

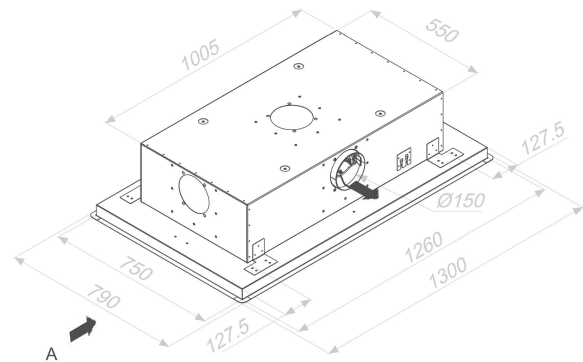

Apertura de puerta / Door opening

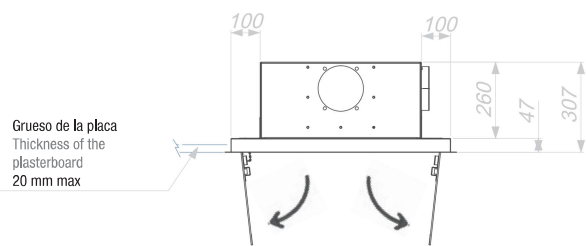

Vista de A  
A view

Altura mínima falso techo  
Minimum height of false ceiling  
130 cm 320 mm

Medidas encastre  
Built in Sizes  
130 cm 1268 x 758



Acceso / Acces WEB

Techo / Ceiling



Techo / Ceiling



Techo / Ceiling

**E-237**  
Touch Down  
Cleaning System  
(EU Patent)



# E-237 Esmaltado y cristal blanco White enamel and glass



## Touch Down Cleaning System

Sistema de limpieza y mantenimiento de la campana con sistema de motor que desciende la campana hasta la altura recomendada (EU Patentado)

Slide Down System for easy cleaning and filter maintenance comes down to any required height (EU Patented)



### SAP

Sistema anti atrapamientos de Pando  
Safe Slide Down System

Modelos / Models

#### S.E.C. System®

##### Motor Interior / Interior Motor

Front. (cm)	Motor	Ø tubo	Clas. Ener.	Ref.	P.V.R
130	V.1130 eco PLUS	Ø150	A	009951	2.995 €

##### Motor Intermedio exterior / Duct-in-line motor

130	V.1550 eco	Ø150	A+	009961	3.595 €
	V.2450 eco	Ø200	A	009962	3.795 €

##### Motor de tejado / Remote motor -Roof Outdoor

130	V.2350 eco	Ø200	A	009963	3.995 €
-----	------------	------	---	--------	---------

Opcionales / Options

Kits de recirculación. Ver página 210  
Activated carbon filters kit. See page 210

Cambio a LED cálido de 3000K. Suministrado con la campana  
LED change to warm light LED 3000K. Available only at the factory 0 €

Notas / Notes

Recorrido estándar del cable 1 m.  
Standard cable length 1 m.

Para otras alturas, consultar con nuestra división técnica.  
For other heights, please check with our Technical department.

#### INCLUIDO / INCLUDED

Este modelo con motorización V.1130 ECO PLUS incorpora de serie 2 m de tubo de extracción de humos espiral Ø150 circular.  
This model with the V.1130 ECO PLUS motor system comes with 2 m of 150 diameter circular spiral extractor flue as standard.

Las unidades con motorizaciones V.2450 Intermedio Exterior y V.2350 Tejado, incorporan de serie 5 m de tubo de extracción de humos SEC System® de Ø203 mm interior y Ø253 mm exterior.

This model with the V.2450 duct-in-line remote motor and V.2350 roof motor system comes with 5 m of S.E.C. fume extractor flue as standard System®, interior Ø 203 mm and exterior Ø 253.

Esquemas medidas / Technical Drawings

#### Motor Interior / Interior Motor

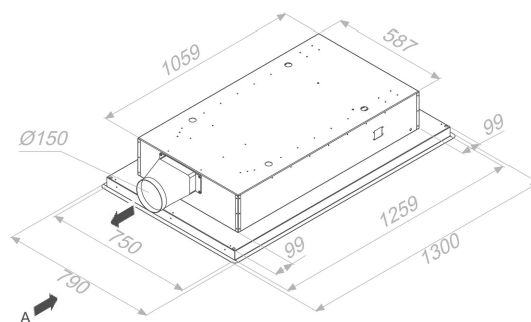

#### Apertura de puerta / Door opening

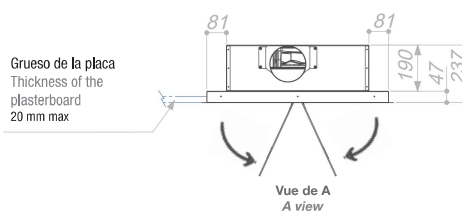

#### Motor Intermedio exterior / Duct-in-line motor

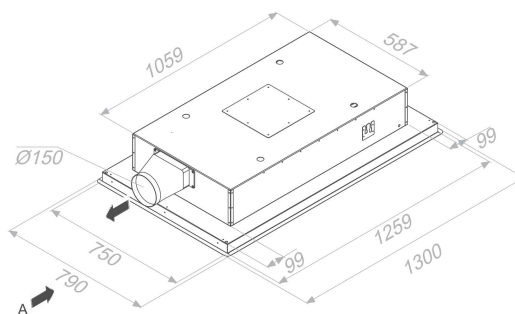

Altura mínima falso techo  
Minimum height of false ceiling

Motor Int	250 mm
Motor Ext Ø 200	300 mm
Motor Ext 260 x 100	250 mm

Medidas encastre  
Built in Sizes

130	1268 x 758
-----	------------



Acceso / Acces WEB

Techo / Ceiling



## **E-237**

**Touch Down  
Cleaning System  
(EU Patented)**

# E-240

Inox - Cristal retroiluminado  
Stainless Steel - Backlit glass



Modelos / Models

### Motor Intermedio exterior / Duct-in-line motor

Front. (cm)	Motor	Ø tubo	Clas. Ener.	Ref.	P.V.R
116	V.2450 eco	Ø200	A	009207	3.095 €

### Motor de tejado / Remote motor -Roof Outdoor

116	V.2350 eco	Ø200	A	009206	3.295 €
-----	------------	------	---	--------	---------

Opcionales / Options

### AirLink

Modelo compatible. Es imprescindible solicitar esta opción en el pedido de la campana. No se equipa de serie.  
Compatible Model. This option must be requested together with the purchase order. Is not included as standard.

0 €

Cambio a LED cálido de 2700K. Suministrado con la campana  
LED change to warm light LED 2700K. Available only at the factory

0 €

Conjunto botonera INOX de encastre a pared.

Solo suministrado con la campana.  
Stainless steel button panel set for embedding into the wall.  
Available only at the factory.

120 €

Conjunto botonera BLANCO de encastre a pared.

Solo suministrado con la campana.  
White enamel button panel set for embedding into the wall.  
Available only at the factory.

150 €

Notas / Notes

Salida de humos de serie: Lateral largo, lateral corto o techo.  
Standard fume outlet option: long side, short side or ceiling.

Este modelo no permite filtros de carbón activado.  
Exit through long side, to be specified on order.



Para otras alturas, consultar con nuestra división técnica.  
For other heights, please check with our Technical department.



Opcional / Options  
Inox / Stainless Steel  
Esmaltado blanco / White

### INCLUIDO / INCLUDED

Las unidades con motorizaciones V.2450 Intermedio Exterior y V.2350 Tejado, incorporan de serie 5 m de tubo de extracción de humos SEC System® de Ø203 mm interior y Ø253 mm exterior.

This model with the V.2450 duct-in-line remote motor and V.2350 roof motor system comes with 5 m of S.E.C. fume extractor flue as standard System®, interior Ø 203 mm and exterior Ø 253.



Esquemas medidas / Technical Drawings

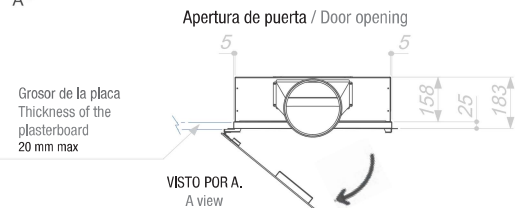
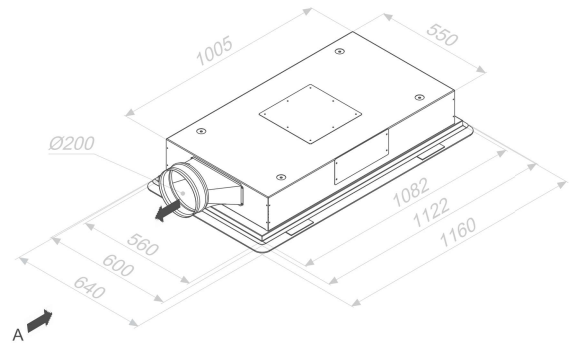

Altura mínima falso techo  
Minimum height of false ceiling

Motor Ext Ø 200 300 mm

Motor Ext 260 x 100 195 mm

Medidas Encastre  
Built in Sizes

116 1087 x 565



Acceso / Acces WEB



**E-240**



# E-245

Esmaltado y cristal blanco  
Una campana, tres soluciones  
White enamel and glass  
One Hood, Three Solutions



Modelos / Models

## S.E.C. System® Motor Interior / Interior Motor

Front. (cm)	Motor	Ø tubo	Clas. Ener.	Ref.	P.V.R
100	V.1130 eco PLUS	Ø150	A	010035	1.995 €

Opcionales / Options

Kits de recirculación. Ver página 210 Activated carbon filters kit. See page 210	
Cambio a LED cálido de 3000K. Suministrado con la campana LED change to warm light LED 3000K. Available only at the factory	0 €
Este modelo puede solicitarse bajo pedido SIN ILUMINACIÓN. This model can be manufactured WITHOUT LIGHTING on request	60 €
Conjunto botonera INOX de encastre a pared. Solo suministrado con la campana. Stainless steel button panel set for embedding into the wall. Available only at the factory.	120 €
Conjunto botonera BLANCO de encastre a pared. Solo suministrado con la campana. White enamel button panel set for embedding into the wall. Available only at the factory.	150 €

Notas / Notes



Para otras alturas, consultar con nuestra división técnica.  
For other heights, please check with our Technical department.



Opcional / Options  
Inox / Stainless Steel  
Esmaltado blanco / White

### INCLUIDO / INCLUDED

Este modelo incorpora de serie 2 m de tubo de extracción de humos espiral 150 circular  
This model comes with 2 m of 150 diameter circular spiral extractor flue as standard.

### Notas instalación / Installation Notes Opción recirculación / Option of recirculation

Distancia entre campana y pared mínimo 2 m.  
Maximum distance between hood and Wall of 2 m.

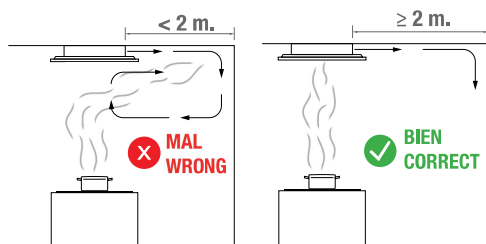

Esquemas medidas / Technical Drawings

### Opción encastrada Built-in option

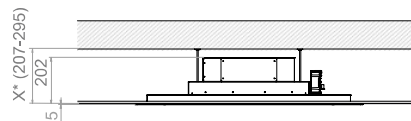
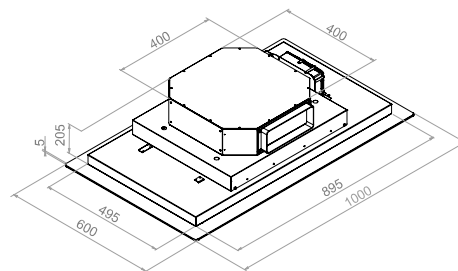

Medidas Encastre  
Built in Sizes  
116 920 x 520

### Opción semi-encastrada Semi-built-in option

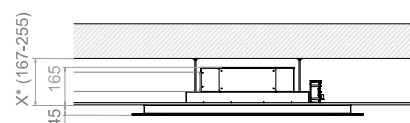
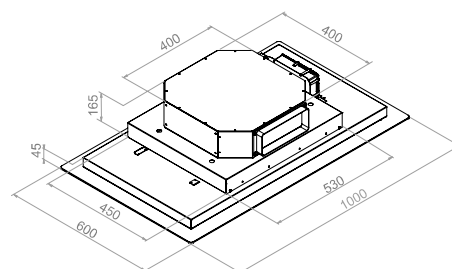

Medidas Encastre  
Built in Sizes  
116 850 x 470

### Opción recirculación. Filtros de carbón activado de alta eficiencia Recirculation option High efficiency reactivated carbon filters

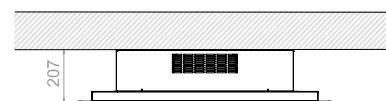
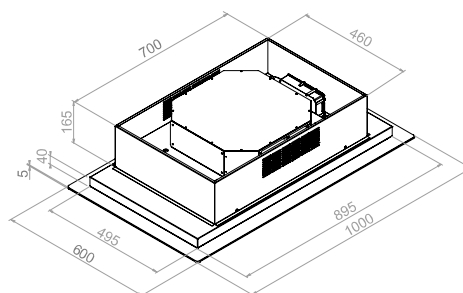

Acceso / Acces WEB



## E-245



**Opción encastrada**  
Built-in option



**Opción semi-encastrada**  
Semi-built-in option



**Opción recirculación.**  
Filtros de carbón de alta eficiencia  
Recycling option - Activated carbon filter





# E-250

Model. 160 cm



# E-250

Inox - Esmaltado blanco o negro epoxi  
Stainless Steel - Epoxy white enamel

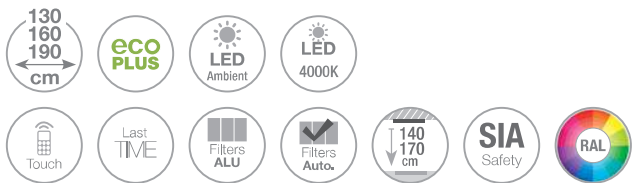

Modelos / Models

## Inox / Stainless Steel

### S.E.C. System® Motor Interior / Interior Motor

Front. (cm)	Motor	Ø tubo	Clas. Ener.	Ref.	P.V.R
130	V.1130 eco PLUS	Ø150	A	009422	2.295 €

### Intermedio exterior / Duct-in-line motor

130	V.1550 eco	Ø150	A+	009535	2.795 €
	V.2450 eco	Ø200	A+	009537	3.295 €
160	V.2450 eco	Ø200	A+	009541	3.795 €
190	V.2450 eco	Ø200	A	009545	4.095 €

### Motor de tejado / Remote motor -Roof Outdoor

130	V.2350 eco	Ø200	A+	009538	3.395 €
160	V.2350 eco	Ø200	A+	009542	3.895 €
190	V.2350 eco	Ø200	A	009546	4.195 €

## Esmaltado blanco / White enamel RAL 9003

### Interior / Interior S.E.C. System®

130	V.1130 eco PLUS	Ø150	A	009423	2.695 €
-----	-----------------	------	---	--------	---------

### Intermedio exterior / Duct-in-line motor

130	V.1550 eco	Ø150	A+	009547	3.195 €
	V.2450 eco	Ø200	A+	009549	3.595 €
160	V.2450 eco	Ø200	A+	009553	3.995 €
190	V.2450 eco	Ø200	A	009557	4.395 €

### Motor de tejado / Remote motor -Roof Outdoor

130	V.2350 eco	Ø200	A+	009550	3.695 €
160	V.2350 eco	Ø200	A+	009554	4.095 €
190	V.2350 eco	Ø200	A	009558	4.495 €

## Esmaltado negro satinado / Black satin enamel

### Interior / Interior S.E.C. System®

130	V.1130 eco PLUS	Ø150	A	009972	2.795 €
-----	-----------------	------	---	--------	---------

### Intermedio exterior / Duct-in-line motor

130	V.1550 eco	Ø150	A+	009973	3.295 €
	V.2450 eco	Ø200	A+	009974	3.695 €
160	V.2450 eco	Ø200	A+	009976	4.095 €
190	V.2450 eco	Ø200	A	009978	4.495 €

### Motor de tejado / Remote motor -Roof Outdoor

130	V.2350 eco	Ø200	A+	009979	3.795 €
160	V.2350 eco	Ø200	A+	009980	4.195 €
190	V.2350 eco	Ø200	A	009981	4.595 €



Opcional / Options  
Inox / Stainless Steel  
Esmaltado blanco / White

Esquemas medidas / Technical Drawings

### Motor Interior / Interior Motor

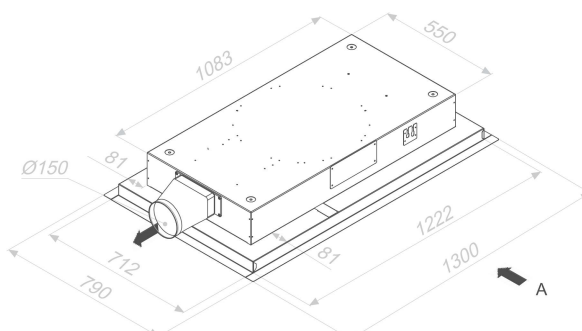

Apertura de puerta / Door opening

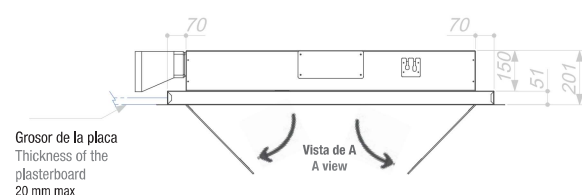

Altura mínima falso techo  
Minimum height of false ceiling

Medidas Encastre  
Built in Sizes

Motor Int.	210 mm	130 cm	1230 x 720
Motor Ext. Ø 200	300 mm	160 cm	1485 x 720
Motor Ext. 260 x 100	210 mm	190 cm	1825 x 720

### Motor Intermedio exterior / Duct-in-line motor

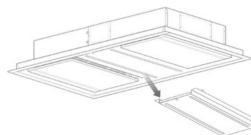
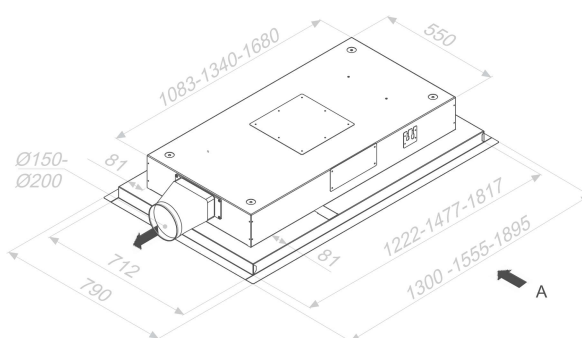

Acceso / Acces WEB

### INCLUIDO / INCLUDED

Este modelo con motorización V.1130 ECO PLUS incorpora de serie 2 m de tubo de extracción de humos espiral Ø150 circular.  
This model with the V.1130 ECO PLUS motor system comes with 2 m of 150 diameter circular spiral extractor flue as standard.

Las unidades con motorizaciones V.2450 Intermedio Exterior y V.2350 Tejado, incorporan de serie 5 m de tubo de extracción de humos SEC System® de Ø203 mm interior y Ø253 mm exterior.

This model with the V.2450 duct-in-line remote motor and V.2350 roof motor system comes with 5 m of S.E.C. fume extractor flue as standard System®, interior Ø 203 mm and exterior Ø 253.



Opcionales / Options

**AirLink**

Modelo compatible. Es imprescindible solicitar esta opción en el pedido de la campana. No se equipa de serie  
Compatible Model. This option must be requested together with the purchase order. Is not included as standard.

0 €

Kits de recirculación. Ver página 210  
Activated carbon filters kit. See page 210

Cambio a LED cálido de 3000K. Suministrado con la campana  
LED change to warm light LED 3000K. Available only at the factory

0 €

Opción plafón de iluminación curvado. Indicar en el pedido  
Curved Lighting panel as option to indicate in the order

60 €

Conjunto botonera INOX de encastre a pared.  
Solo suministrado con la campana.  
Stainless steel button panel set for embedding into the wall.  
Available only at the factory.

120 €

Conjunto botonera BLANCO de encastre a pared.  
Solo suministrado con la campana.  
White enamel button panel set for embedding into the wall.  
Available only at the factory.

150 €

Notas / Notes

Salida de humos de serie lateral corto para motor interior  
Standard short side or ceiling fume outlet for interior motor

Salida de humos lateral largo, indicar en pedido  
Long side exit, has to be mentioned in the order

La campana de 130 y 160 cm incorporan 2 filtros y 1 zona de iluminación.  
El modelo de 190 cm. incorpora 3 filtros y 2 zonas de iluminación  
The 130 and 160 cm hood includes 2 filters and 1 lighting area.  
The 190 cm model. includes 3 filters and 2 lighting areas.



Para otras alturas, consultar con nuestra división técnica.  
For other heights, please check with our Technical department.

**Bajo presupuesto / On request**

Modelo personalizable en cualquier color de la carta RAL  
Customizable model in any color from the RAL chart



**E-250**

# E-252

Inox - imprimación puertas  
Stainless Steel - Backlit glass

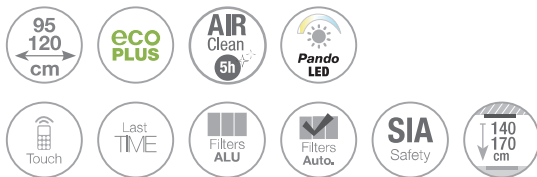

Modelos / Models

## S.E.C. System® Motor Interior / Interior Motor

Front. (cm)	Motor	Ø tubo	Clas. Ener.	Ref.	P.V.R
95	V.1130 eco PLUS	Ø150	A	010214	1.995 €
120	V.1130 eco PLUS	Ø150	A	010218	2.195 €

## Motor Intermedio exterior / Duct-in-line motor

95	V.1550 eco	Ø150	A	010215	2.495 €
	V.2450 eco	Ø200	A	010216	2.950 €
120	V.1550 eco	Ø150	A	010219	2.695 €
	V.2450 eco	Ø200	A	010220	3.150 €

## Motor de tejado / Remote motor -Roof Outdoor

95	V.2350 eco	Ø200	A	010217	3.250 €
120	V.2350 eco	Ø200	A	010221	3.450 €

Opcionales / Options

### AirLink

Modelo compatible. Es imprescindible solicitar esta opción en el pedido de la campana. No se equipa de serie. 0 €  
Compatible Model. This option must be requested together with the purchase order. Is not included as standard.

Kits de recirculación. Ver página 210  
Activated carbon filters kit. See page 210

Este modelo puede solicitarse bajo pedido SIN ILUMINACIÓN. 60 €  
This model can be manufactured WITHOUT LIGHTING on request

Conjunto botonera INOX de encastre a pared. Solo suministrado con la campana. 120 €  
Stainless steel button panel set for embedding into the wall. Available only at the factory.

Conjunto botonera BLANCO de encastre a pared. Solo suministrado con la campana. 150 €  
White enamel button panel set for embedding into the wall. Available only at the factory.

Notas / Notes

### AirClean

Sistema automático de funcionamiento del motor 10 min. cada hora durante 5 horas.  
Automatic working motor system for 10 minutes every hour during 5 hours.

Caja motor rotativa : La salida de humos puede cambiarse gracias a la caja motor rotativa  
Motor Box rotary : Exit position can be changed thanks to its rotative motor box



Para otras alturas, consultar con nuestra división técnica.  
For other heights, please check with our Technical department.



Opcional / Options  
Inox / Stainless Steel  
Esmaltado blanco / White

Esquemas medidas / Technical Drawings

## Motor Interior / Interior Motor

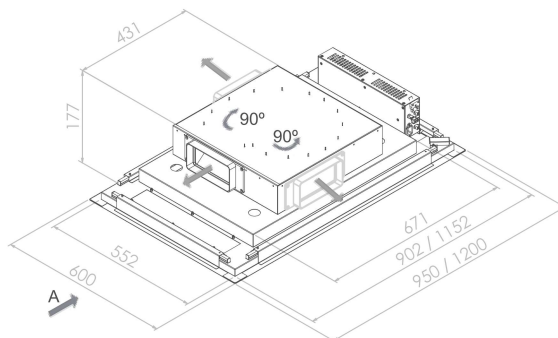

Apertura de puerta / Door opening

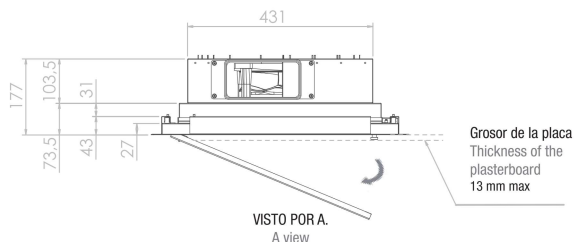

## Motor Intermedio exterior / Duct-in-line motor

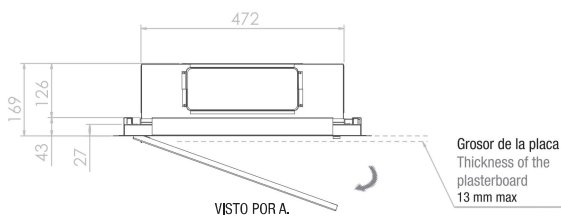
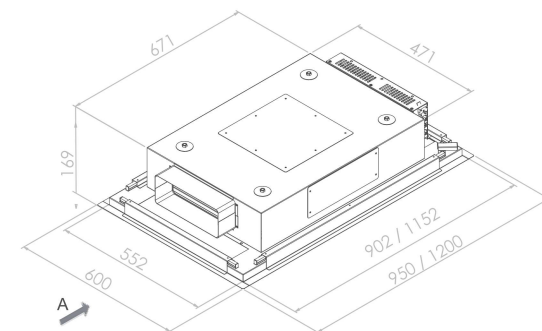

### Medidas Encastre

Built in Sizes

95 cm 548,4 x 902

120 cm 548,4 x 1152

### Altura mínima falso techo

Minimum height of false ceiling

Motor Int. 210 mm

Motor Ext. Ø 200 300 mm

Motor Ext. □ 260 x 100 210 mm



Acceso / Acces WEB

## INCLUIDO / INCLUDED

Este modelo con motorización V.1130 ECO PLUS incorpora de serie 2 m de tubo de extracción de humos espiral Ø150 circular.  
This model with the V.1130 ECO PLUS motor system comes with 2 m of 150 diameter circular spiral extractor flue as standard.

Las unidades con motorizaciones V.2450 Intermedio Exterior y V.2350 Tejado, incorporan de serie 5 m de tubo de extracción de humos SEC System® de Ø203 mm interior y Ø253 mm exterior.  
This model with the V.2450 duct-in-line remote motor and V.2350 roof motor system comes with 5 m of S.E.C. fume extractor flue as standard System®, interior Ø 203 mm and exterior Ø 253.

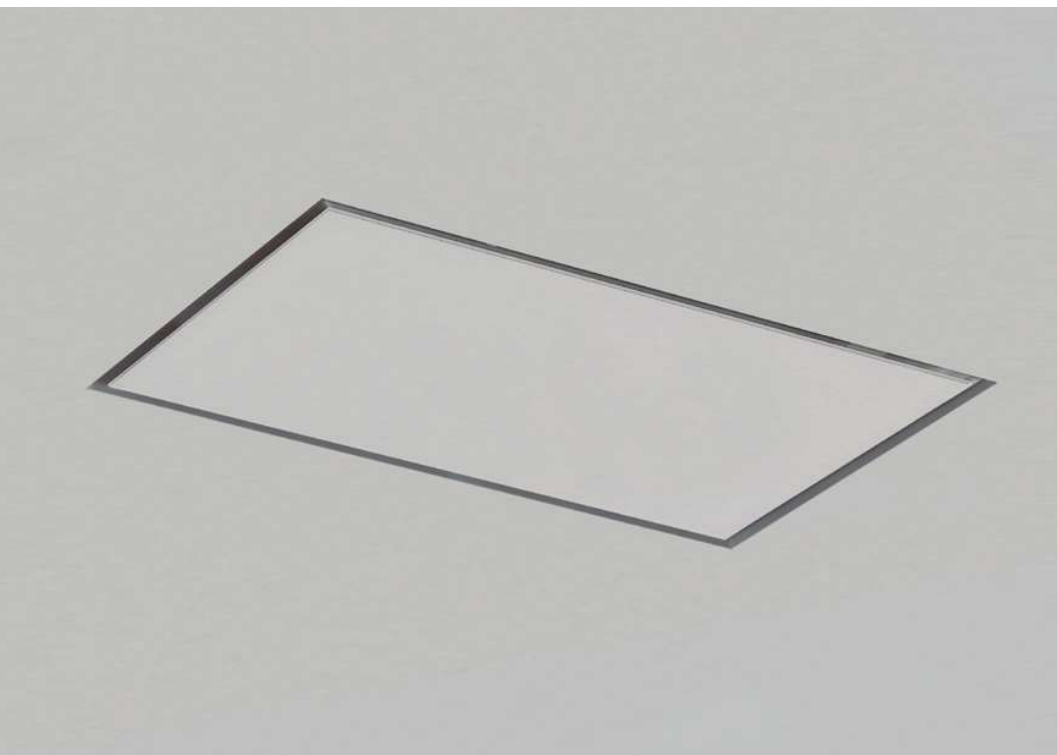



# E-265

Inox - Esmaltado y cristal blanco Ral 9003 o Cristal Negro  
Stainless Steel - White enamel and glass or Black glass



Modelos / Models

## Cristal Blanco

### S.E.C. System® Motor Interior / Interior Motor

Front. (cm)	Motor	Ø tubo	Clas. Ener.	Ref.	P.V.R
130	V.1130 eco PLUS	Ø150	A	009586	2.995 €

### Motor Intermedio exterior / Duct-in-line motor

130	V.1550 eco	Ø150	A+	009587	3.695 €
	V.2450 eco	Ø200	A+	009589	4.195 €
160	V.2450 eco	Ø200	A+	009593	4.795 €
190	V.2450 eco	Ø200	A	009597	5.395 €

### Motor de tejado / Remote motor -Roof Outdoor

130	V.2350 eco	Ø200	A+	009590	4.395 €
160	V.2350 eco	Ø200	A+	009594	4.995 €
190	V.2350 eco	Ø200	A	009598	5.595 €

Opcionales / Options

### AirLink

Modelo compatible. Es imprescindible solicitar esta opción en el pedido de la campana. No se equipa de serie  
Compatible Model. This option must be requested together with the purchase order. Is not included as standard. 0 €

Kits de recirculación. Ver página 210  
Activated carbon filters kit. See page 210

Opción cambio de LED ambiente original de 3000K a 4000K. Suministrado con la campana.  
Option of changing the original LED for a 4000K light LED. Optional change only possible in factory. 0 €

Conjunto botonera INOX de encastre a pared. Solo suministrado con la campana.  
Stainless steel button panel set for embedding into the wall. Available only at the factory. 120 €

Conjunto botonera BLANCO de encastre a pared. Solo suministrado con la campana.  
White enamel button panel set for embedding into the wall. Available only at the factory. 150 €

Modelos / Models

## Cristal Negro

### S.E.C. System® Motor Interior / Interior Motor

Front. (cm)	Motor	Ø tubo	Clas. Ener.	Ref.	P.V.R
130	V.1130 eco PLUS	Ø150	A	010319	2.995 €

### Motor Intermedio exterior / Duct-in-line motor

130	V.1550 eco	Ø150	A+	010320	3.695 €
	V.2450 eco	Ø200	A+	010321	4.195 €
160	V.2450 eco	Ø200	A+	010323	4.795 €
190	V.2450 eco	Ø200	A	010325	5.395 €

### Motor de tejado / Remote motor -Roof Outdoor

130	V.2350 eco	Ø200	A+	010322	4.395 €
160	V.2350 eco	Ø200	A+	010324	4.995 €
190	V.2350 eco	Ø200	A	010326	5.595 €

Notas / Notes

Salida de humos de serie lateral corto para motor interior  
Standard short side or ceiling fume outlet for interior motor

Opción salida de humos lateral largo para motor interior. Indicar en pedido  
Long side fume outlet option for interior motor, to be specified on order

Salida de humos de serie lateral largo, corto o techo para motor exterior  
Standard long or short side or ceiling fume outlet for exterior motor

La campana de 130 y 160 cm incorporan 2 filtros y 1 zona de iluminación.  
El modelo de 190 cm. incorpora 3 filtros y 2 zonas de iluminación.  
The 130 and 160 cm hood includes 2 filters and 1 lighting area.  
The 190 cm model. includes 3 filters and 2 lighting areas.

Para otras alturas, consultar con nuestra división técnica.  
For other heights, please check with our Technical department.



Opcional / Options  
Inox / Stainless Steel  
Esmaltado blanco / White

Techo / Ceiling

Esquemas medidas / Technical Drawings

### Motor Interior / Interior Motor

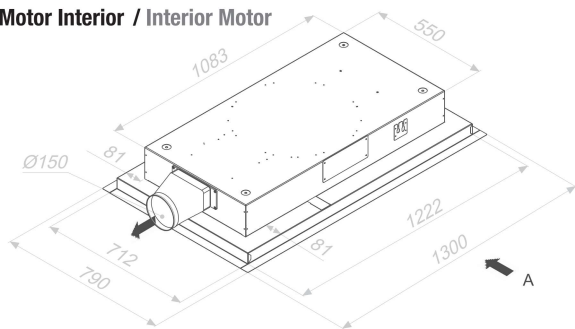

Apertura de puerta / Door opening

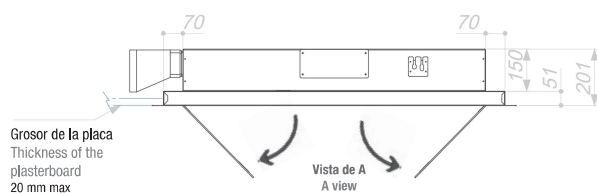

Grosor de la placa  
Thickness of the  
plasterboard  
20 mm max

Vista de A  
A view

### Motor Intermedio exterior / Duct-in-line motor

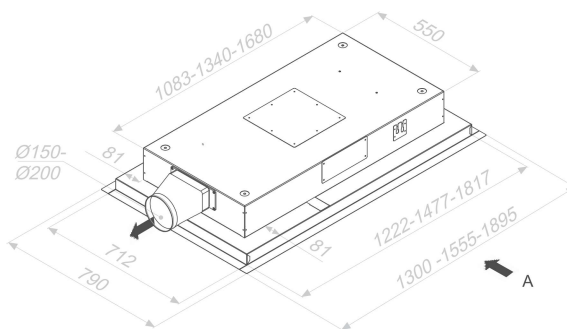

Acceso / Acces WEB

Altura mínima falso techo Minimum height of false ceiling		Medidas Encastre Built in Sizes	
Motor Int.	210 mm	130 cm	1230 x 720
Motor Ext. Ø 200	300 mm	160 cm	1485 x 720
Motor Ext. □ 260 x 100	210 mm	190 cm	1825 x 720

### INCLUIDO / INCLUDED

Este modelo con motorización V.1130 ECO PLUS incorpora de serie 2 m de tubo de extracción de humos espiral Ø150 circular.  
This model with the V.1130 ECO PLUS motor system comes with 2 m of 150 diameter circular spiral extractor flue as standard.

Las unidades con motorizaciones V.2450 Intermedio Exterior y V.2350 Tejado, incorporan de serie 5 m de tubo de extracción de humos SEC System® de Ø203 mm interior y Ø253 mm exterior.  
This model with the V.2450 duct-in-line remote motor and V.2350 roof motor system comes with 5 m of S.E.C. fume extractor flue as standard System®, interior Ø 203 mm and exterior Ø 253.



Model. 130 cm

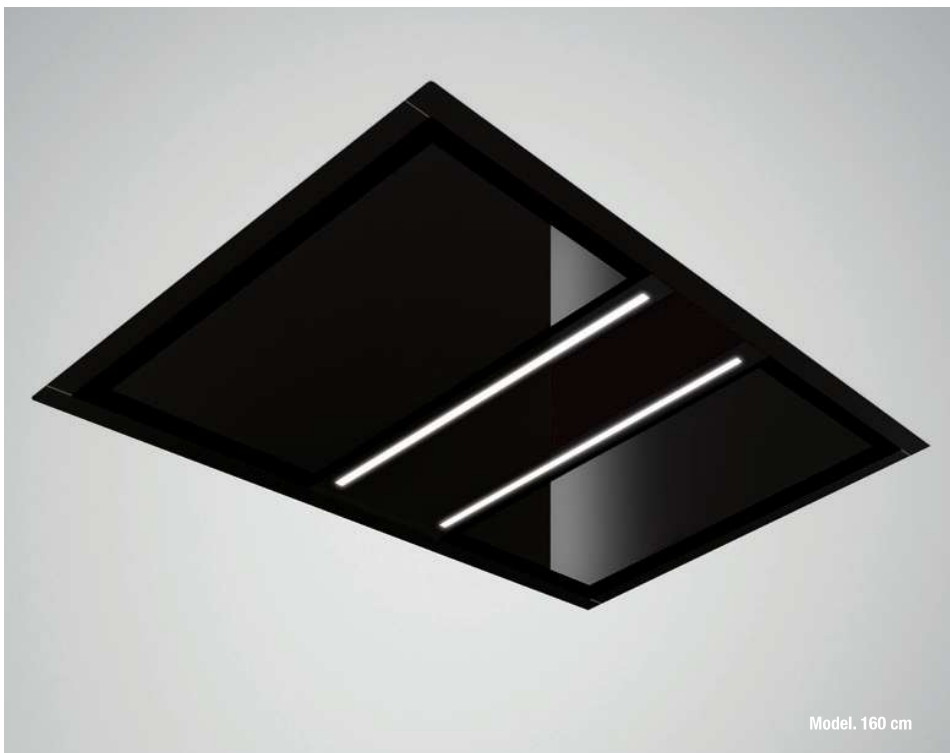

Model. 160 cm

**E-265**

# E-295

Inox - Blanco  
Stainless Steel - White



Modelos / Models

## Inox / Stainless Steel

### S.E.C. System®

#### Motor Interior / Interior Motor

Front. (cm)	Motor	Ø tubo	Clas. Ener.	Ref.	P.V.R
90	V.850	Ø150	A	009201.A	999 €

#### Motor Interior / Motor Intermedio Exterior

#### Interior Motor / Duct-in-line motor

90	V.1350	Ø150	B	009964.A	1.295 €
----	--------	------	---	----------	---------

## Blanco / White

### S.E.C. System®

#### Motor Interior / Interior Motor

90	V.850	Ø150	A	10329	999 €
----	-------	------	---	-------	-------

#### Motor Interior / Motor Intermedio Exterior

#### Interior Motor / Duct-in-line motor

90	V.1350	Ø150	B	10330	1.295 €
----	--------	------	---	-------	---------

Opcionales / Options

### AirLink

Modelo compatible. Es imprescindible solicitar esta opción en el pedido de la campana. No se equipa de serie  
Compatible Model. This option must be requested together with the purchase order. Is not included as standard.

0 €

Kits de recirculación. Ver página 210  
Activated carbon filters kit. See page 210

Cambio a LED cálido de 3000K. Suministrado con la campana  
LED change to warm light LED 3000K. Available only at the factory

60 €

Conjunto botonera INOX de encastre a pared.  
Solo suministrado con la campana.

Stainless steel button panel set for embedding into the wall.  
Available only at the factory.

120 €

Conjunto botonera BLANCO de encastre a pared.  
Solo suministrado con la campana.

White enamel button panel set for embedding into the wall.  
Available only at the factory.

150 €

Notas / Notes

Salida de humos de serie: Lateral largo  
Standard fume outlet: long side



Para otras alturas, consultar con nuestra división técnica.  
For other heights, please check with our Technical department.

### Bajo presupuesto / On request

Modelo personalizable en cualquier color de la carta RAL  
Customizable model in any color from the RAL chart



Opcional / Options  
Inox / Stainless Steel  
Esmaltado blanco / White

Esquemas medidas / Technical Drawings



## Doble sistema de fácil instalación Double easy installation System

Ver pág. 119 / See page 119

### Motor Interior / Interior Motor

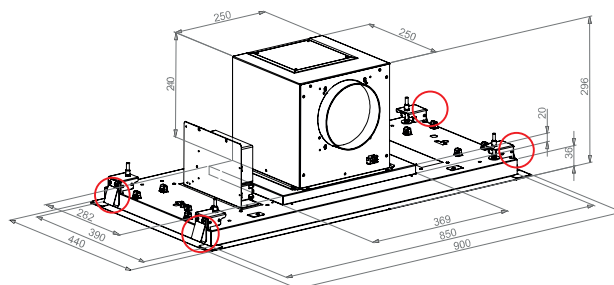

Peso / Weight: 16 kg

Apertura de puerta  
Door opening

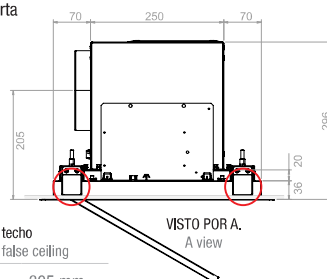

Grosor de la placa  
Thickness of the plasterboard  
20 mm max

Altura mínima falso techo  
Minimum height of false ceiling

Motor Int. 305 mm

Motor Ext. 295 mm

### Motor Intermedio exterior / Duct-in-line motor

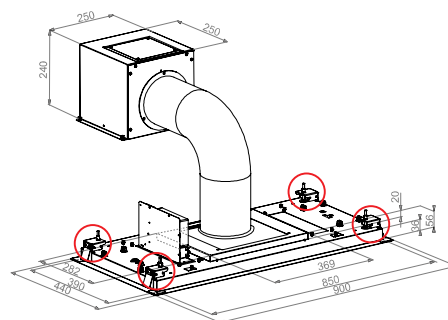

Peso / Weight: 16 kg

Apertura de puerta  
Door opening

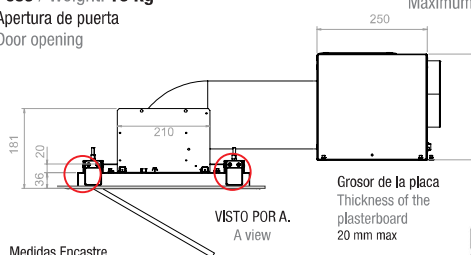

Distancia máxima  
Maximum distance

Grosor de la placa  
Thickness of the plasterboard  
20 mm max

Medidas Encastre  
Built in Sizes

90 cm 860 x 395

90 cm 860 x 395



Acceso / Acces WEB



**E-295**







**E-297**

*Model. 120 cm*

# E-297

Inox - Cristal blanco o Negro  
Stainless Steel - White glass or Black glass



Modelos / Models

## Inox / Stainless Steel

### Interior / Interior S.E.C. System®

Front. (cm)	Motor	Ø tubo	Clas. Ener.	Ref.	P.V.R
95	V.1130 eco PLUS	Ø150	A+	009800.A	1.595 €
120	V.1130 eco PLUS	Ø150	A+	010098	1.695 €

### Intermedio exterior / Duct-in-line motor

95	V.1550 eco	Ø150	A+	009836	1.995 €
	V.2450 eco	Ø200	A+	009837	2.395 €
120	V.1550 eco	Ø150	A+	010067	2.095 €
	V.2450 eco	Ø200	A+	010068	2.595 €

### Motor exterior a muro / Remote motor - Wall Outdoor

95	V.1300 eco	Ø150	A+	010423	2.095 €
120	V.1300 eco	Ø150	A+	010425	2.295 €

### Motor de tejado / Remote motor -Roof Outdoor

95	V.2350 eco	Ø200	A+	009838	2.495 €
120	V.2350 eco	Ø200	A+	010069	2.795 €

## Cristal blanco / White glass

### Interior / Interior S.E.C. System®

95	V.1130 eco PLUS	Ø150	A+	009801.A	1.695 €
120	V.1130 eco PLUS	Ø150	A+	010099	1.795 €

### Intermedio exterior / Duct-in-line motor

95	V.1550 eco	Ø150	A+	009839	2.095 €
	V.2450 eco	Ø200	A+	009840	2.495 €
120	V.1550 eco	Ø150	A+	010070	2.295 €
	V.2450 eco	Ø200	A+	010071	2.795 €

### Motor exterior a muro / Remote motor - Wall Outdoor

95	V.1300 eco	Ø150	A+	010424	2.295 €
120	V.1300 eco	Ø150	A+	010426	2.495 €

### Motor de tejado / Remote motor -Roof Outdoor

95	V.2350 eco	Ø200	A+	009841	2.595 €
120	V.2350 eco	Ø200	A+	010072	2.995 €

## Cristal negro / Black glass

### Interior / Interior S.E.C. System®

95	V.1130 eco PLUS	Ø150	A+	010311	1.695 €
120	V.1130 eco PLUS	Ø150	A+	010315	1.795 €

### Intermedio exterior / Duct-in-line motor

95	V.1550 eco	Ø150	A+	010312	2.095 €
	V.2450 eco	Ø200	A+	010313	2.495 €
120	V.1550 eco	Ø150	A+	010316	2.295 €
	V.2450 eco	Ø200	A+	010317	2.795 €

### Motor exterior a muro / Remote motor - Wall Outdoor

95	V.1300 eco	Ø150	A+	010435	2.295 €
120	V.1300 eco	Ø150	A+	010436	2.495 €

### Motor de tejado / Remote motor -Roof Outdoor

95	V.2350 eco	Ø200	A+	010314	2.595 €
120	V.2350 eco	Ø200	A+	010318	2.995 €

Esquemas medidas / Technical Drawings



**Doble sistema de fácil instalación**  
*Double easy installation System*  
Ver pág. 119 / See page 119

### Motor Interior / Interior Motor

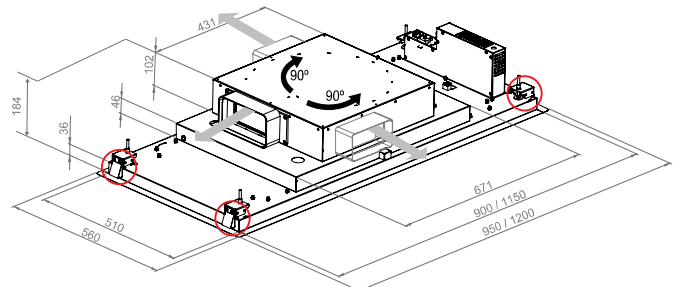

**Peso / Weight mod. 95 : 22 kg / Peso / Weight mod. 120 : 27 kg**

**Apertura de puerta reversible / Reversible door opening**  
**Box rotativo / Rotary Motor Box**

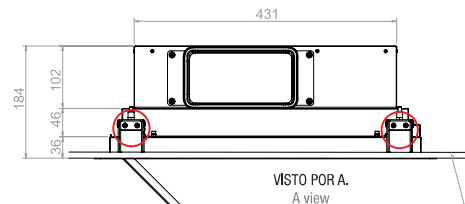

Grosor de la placa  
Thickness of the plasterboard  
20 mm max

Altura mínima falso techo  
Minimum height of false ceiling

Motor Int.	190 mm
Motor Ext. Ø 200	250 mm
Motor Ext. □ 260 x 100	160 mm

Medidas Encastre Built in Sizes	
95 cm	910 x 515
120 cm	1160 x 515

### Motor Intermedio exterior / Duct-in-line motor

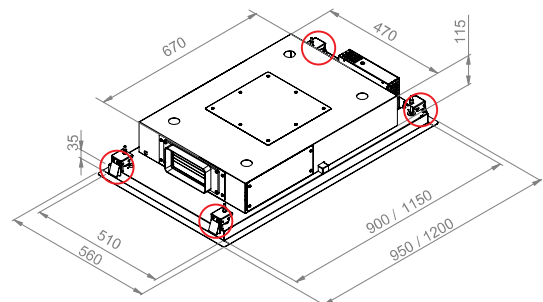

**Apertura de puerta reversible / Reversible door opening**  
**Box rotativo / Rotary Motor Box**

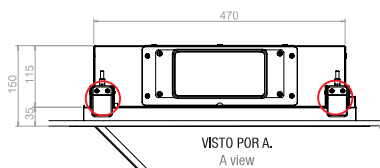

Grosor de la placa  
Thickness of the plasterboard  
20 mm max

Medidas Encastre Built in Sizes	
95 cm	910 x 515
120 cm	1160 x 515



Acceso / Acces WEB

Techo / Ceiling

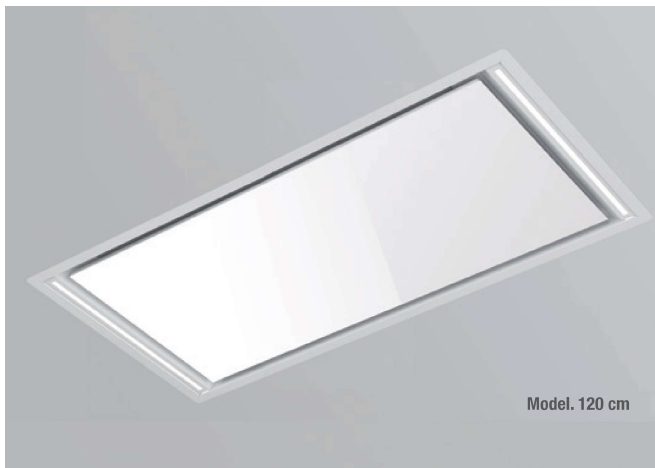

Model. 120 cm



Model. 95 cm

### INCLUIDO / INCLUDED

Este modelo con motorización V.1130 ECO PLUS incorpora de serie 2 m de tubo de extracción de humos espiral Ø150 circular.  
This model with the V.1130 ECO PLUS motor system comes with 2 m of 150 diameter circular spiral extractor flue as standard.

Las unidades con motorizaciones V.2450 Intermedio Exterior y V.2350 Tejado, incorporan de serie 5 m de tubo de extracción de humos SEC System® de Ø203 mm interior y Ø253 mm exterior.

This model with the V.2450 duct-in-line remote motor and V.2350 roof motor system comes with 5 m of S.E.C. fume extractor flue as standard System®, interior Ø 203 mm and exterior Ø 253.

# E-297

### Opcionales / Options

#### AirLink

Modelo compatible. Es imprescindible solicitar esta opción en el pedido de la campana. No se equipa de serie 0 €

Compatible Model. This option must be requested together with the purchase order. Is not included as standard.

Kits de recirculación. Ver página 210  
Activated carbon filters kit. See page 210

Este modelo puede solicitarse bajo pedido SIN ILUMINACIÓN. 60 €  
This model can be manufactured WITHOUT LIGHTING on request

Conjunto botonera INOX de encastre a pared.  
Solo suministrado con la campana. 120 €  
Stainless steel button panel set for embedding into the wall.  
Available only at the factory.

Conjunto botonera BLANCO de encastre a pared.  
Solo suministrado con la campana. 150 €  
White enamel button panel set for embedding into the wall.  
Available only at the factory.

### Notas / Notes

Caja motor rotativa : La salida de humos puede cambiarse gracias a la caja motor rotativa  
Motor Box rotary : Exit position can be changed thanks to its rotative motor box

#### AirClean

Sistema automático de funcionamiento del motor 10 min. cada hora durante 5 horas.  
Automatic working motor system for 10 minutes every hour during 5 hours.



Para otras alturas, consultar con nuestra división técnica.  
For other heights, please check with our Technical department.

#### Bajo presupuesto / On request

Modelo personalizable en cualquier color de la carta RAL  
Customizable model in any color from the RAL chart



Opcional / Options  
Inox / Stainless Steel  
Esmaltado blanco / White



# SKYRING



## Modelos / Models

### S.E.C. System® Interior / Interior

Color	Motor	Ø tubo	Clas. Ener.	Ref.	P.V.R
Plata / Silver	V.1130 eco PLUS	Ø150	B	010004	1.990 €
Oro / Gold	V.1130 eco PLUS	Ø150	B	010005	1.990 €
Cobre / Copper	V.1130 eco PLUS	Ø150	B	010006	1.990 €
Blanco / White	V.1130 eco PLUS	Ø150	B	010007	1.990 €
Negro Sat. / Black Satin	V.1130 eco PLUS	Ø150	B	010008	1.990 €

### Intermedio exterior / Duct-in-line motor

Plata / Silver	V.1550 eco	Ø150	A	010009	2.595 €
Oro / Gold	V.1550 eco	Ø150	A	010010	2.595 €
Cobre / Copper	V.1550 eco	Ø150	A	010011	2.595 €
Blanco / White	V.1550 eco	Ø150	A	010012	2.595 €
Negro Sat. / Black Satin	V.1550 eco	Ø150	A	010013	2.595 €



## Techo / Ceiling

## Opcionales / Options

### AirLink

Modelo compatible. Es imprescindible solicitar esta opción en el pedido de la campana. No se equipa de serie  
Compatible Model. This option must be requested together with the purchase order. Is not included as standard.

0 €

Kits de recirculación. Ver página 210  
Activated carbon filters kit. See page 210

Kit cables / kit cables

L: 2500 mm	500050400126	45 €
L: 4000 mm	500050400127	90 €

## Notas / Notes

Iluminación circular LED 14W  
Circular 14W LED Lighting

Altura estándar del cable 1560 mm. No es posible mayor extensión del cable.  
Standard Cable length 1560 mm. Longer sizes not available



Para otras alturas, consultar con nuestra división técnica.  
For other heights, please check with our Technical department.

## Esquemas medidas / Technical Drawings

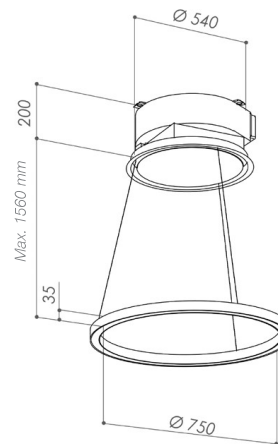

Zona de cocción recomendada:  
Modular 30-40 cm  
Compacta máx. 60 cm  
Recommended Cooktop:  
Modular 30-40 cm  
Compact: Max 60 cm

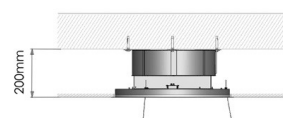

Regulación de medida en falso techo de 200 a 300 mm.  
200-300 mm False Ceiling regulation

Altura mínima falso techo  
Minimum height of false ceiling

Motor Int. 200 mm

Motor Ext. 200 mm

Medidas Encastre  
Built in Sizes 75 cm Ø510



Acceso / Acces WEB



# SKYRING



# CAMPANAS DE INTEGRACIÓN

## INTEGRATED COOKER HOODS





**E-390** Campana integrada en la placa de cocción.  
Cristal negro

**E-391** Hood integrated into induction cooktop.  
Black glass



Instalación fácil y compatible con cualquier tipo de muebles  
Easy and compatible with all kind of furniture

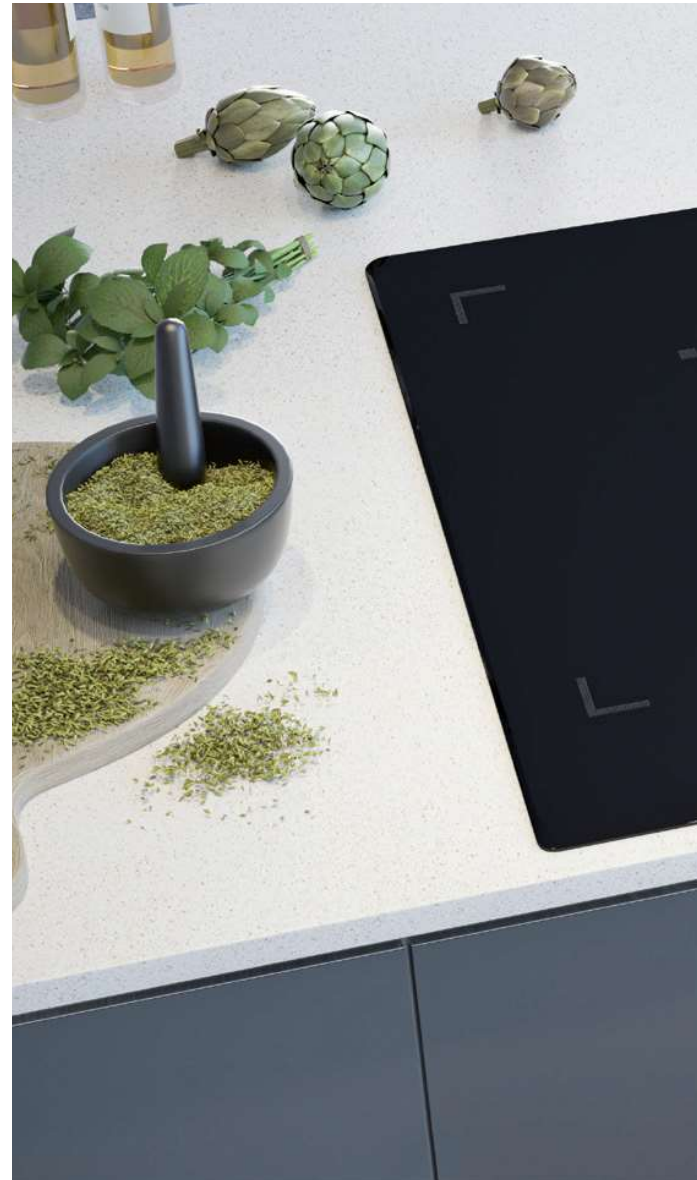

Integración / Integrated



**E-390**  
BISELADA  
BEVELED



**E-391**  
SOBRE ENCIMERA  
BUILT-IN



**E-391**  
ENCASTRADA  
FLUSHED



**E-390**  
**E-391**

Integración / Integrated

# E-390

Campana integrada en la placa de cocción. Cristal negro

# E-391

Hood integrated into induction cooktop. Black glass



Modelos / Models

## E-390 Cristal biselado / Beveled glass

### S.E.C. System® Motor Interior / Interior Motor

Motor	Ø tubo	Clas. Ener.	Ref.	P.V.R
Extracción / Extraction V.1130 eco PLUS	Ø150	A+	010074	2.645 €
Recirculación / Recirculation V.1130 eco PLUS	Ø150		010075	2.795 €
Recirculación+Difusor (Salida Frontal o Posterior) Recirculation+Diffuser (Front or Rear Exit) V.1130 eco PLUS	Ø150		010076	2.995 €
Recirculación+Difusor (Salida Lateral) Recirculation+Diffuser (Side Exit) V.1130 eco PLUS	Ø150		010199	2.995 €

## E-391 Cristal recto / Straight glass

### S.E.C. System® Motor Interior / Interior Motor

Motor	Ø tubo	Clas. Ener.	Ref.	P.V.R
Extracción / Extraction V.1130 eco PLUS	Ø150	A+	010064	2.545 €
Recirculación / Recirculation V.1130 eco PLUS	Ø150		010065	2.695 €
Recirculación + Difusor (Salida Frontal o Posterior) Recirculation + Diffuser (Front or Rear Exit) V.1130 eco PLUS	Ø150		010066	2.895 €
Recirculación+Difusor (Salida Lateral) Recirculation+Diffuser (Side Exit) V.1130 eco PLUS	Ø150		010200	2.895 €

Esquemas medidas / Technical Drawings

### Medidas Encastre / Dimensions built in size

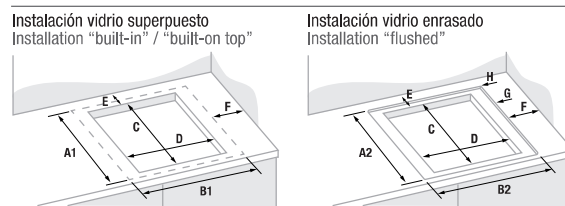

Tamaño del Vidrio Size of glass	Tamaño de Corte Size of cut	Fondo Rear	Lado Lateral	Radio Radio	Instalación en vidrio al ras Installation "flushed"				
A1	B1	C	D	E (min)	F (min)	H	A2	B2	G*
520	780	490	750	38	40	8	524	784	5

\* Profundidad/Depth

La medida exterior mínima del mueble para instalar este tipo de campana es de 900 x 560 mm.

The minimal external dimension of furniture to install this hood should be 900 x 560 mm.

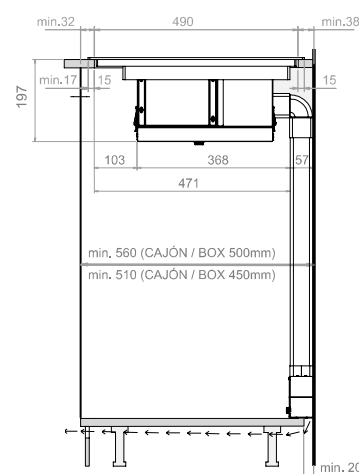

Atención: Apertura mínima para la ventilación de humos > 500 cm<sup>2</sup>  
Venting Minimum Opening > 500 cm<sup>2</sup>

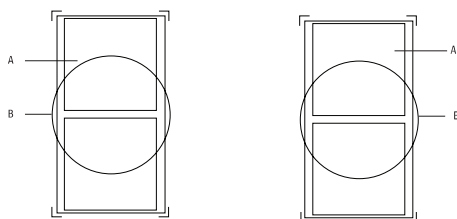

	EXT.	MÍN.	MÁX.	Power W	Booster W	Súper Booster W
A	220 x 180 mm	100 mm	Ø 180 mm	2100w	2600w	3700w
B	220 x 360 mm	135 mm	Ø 220 mm	-	-	-

### Características de la campana

Mínima altura interior de la campana 197 mm	Shallow built-under in 197 mm
Motor de bajo consumo y ecoeficiente	Eco-efficient low consumption motor
Bajo nivel sonoro: 61 dB max	Lowest Noise levels Max 61 Db
Excelente velocidad de aspiración à 10 M/s	Excellent Airflow speed levels on top 10 M/s
2 mode de recirculación: filtros de carbono reactivables o filtros cerámicos de última generación	2 Recirc. versions Reactivated Carbon Filters or high Efficiency Ceramic Filters built in 60 mm plinth
Conducto rectangular trasero: 220 x 55 mm	Rear 220 x 55 mm rectangular ducting pipe (Extraction version)

### Características de la placa de inducción

Stop&Go	Stop&Go
Cristal cerámico Keraspectrum	Keraspectrum Glass and E.G.O High Tech inside
Cocción automática	Automatic cooking
La función Bridge permite acoplar 2 inductores de cada lado para hacer un único conjunto	Bridge function allows coupling 2 inductors on each side to make it a unique set
Detección inteligente de recipiente	Intelligent self-pot detection
La función Chef le permite modificar la posición de la sartén dentro de la placa sin perder la potencia de calor	Chef function. Let you easily move the pan from Inductors left to right keeping the heating power level
Indicador de calor residual	Residual heat indicator
Función Booster y Doble Booster	Booster & Double Booster function
Acelerador de calor	Heating accelerator

### Notas / Notes

Incluye bandeja de limpieza fácil que recoge el aceite  
Includes easy-cleaning tray for collection of oils



Acceso / Acces WEB  
E-390



Acceso / Acces WEB  
E-391

Integración / Integrated



4 Opciones de instalación  
4 Ways to be installed

Cada referencia incluye todos los accesorios necesarios para la instalación.  
Each reference includes all necessary accessories for the installation.



**E-390 (ref. 10074) - E-391 (ref. 10064)**  
Version Salida exterior  
Version: External exit

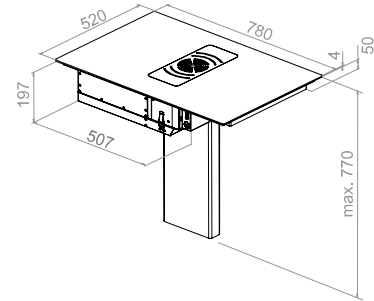

**E-390 (ref. 10075) - E-391 (ref. 10065)**  
Versión Recirculación y filtros FCLR-AE  
Version: Recirculation and FCLR-AE filters

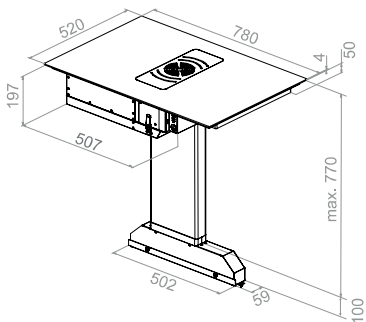

**E-390 (ref. 10076) - E-391 (ref. 10066)**  
Versión Recirculación con difusor y filtros cerámicos FCCR-AE.  
Version: Recirculation with diffuser and ceramic filter FCCR-AE

Salida Frontal / Front Exit

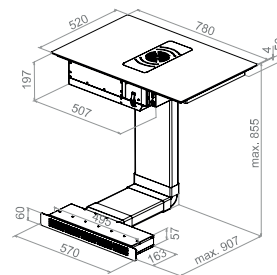

Salida Posterior / Rear Exit

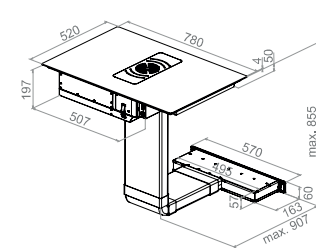

Esquema Difusor zócalo ver pág. 210 / Plinth Diffuser technical drawings see page 210



**E-390 (ref. 10199) - E-391 (ref. 10200)**  
Versión Recirculación con difusor y filtros cerámicos FCCR-AE.  
Version: Recirculation with diffuser and ceramic filter FCCR-AE

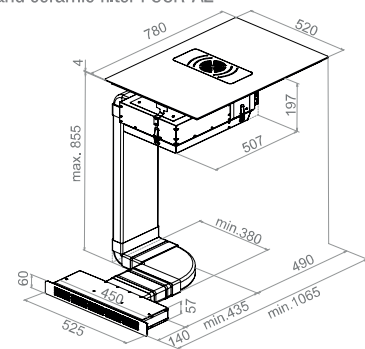

Esquema Difusor zócalo ver pág. 210 / Plinth Diffuser technical drawings see page 210



# E-392 E-393

Campana integrada  
en la placa de cocción.  
Cristal negro

Hood integrated into  
induction cooktop.  
Black glass



## E-392 BISELADA BEVELED



## E-393 ENCASTRADA FLUSHED





**E-393**  
SOBRE ENCIMERA  
BUILT-IN



**E-392**  
**E-393**

Integración / Integrated

# E-392

# E-393

Campana integrada en la placa de cocción. Cristal negro  
Hood integrated into induction cooktop. Black glass



Modelos / Models

## E-392 Cristal biselado / Beveled glass

### S.E.C. System® Motor Interior / Interior Motor

Motor	Ø tubo	Clas. Ener.	Ref.	P.V.R
Recirculación / Recirculation V.1130 eco PLUS	Ø150	A+	010299	2.495 €

## E-393 Cristal recto / Straight glass

### S.E.C. System® Motor Interior / Interior Motor

Motor	Ø tubo	Clas. Ener.	Ref.	P.V.R
Recirculación / Recirculation V.1130 eco PLUS	Ø150	A+	010300	2.395 €

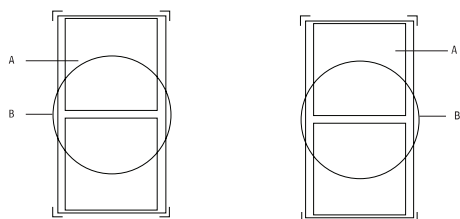

	□ EXT.	□ MÍN.	□ MÁX.	Power W	Booster W	Súper Booster W
A	220 x 180 mm	100 mm	Ø 180 mm	2100w	2600w	3700w
B	220 x 360 mm	135 mm	Ø 220 mm	-	-	-

### Características de la campana

Minima altura interior de la campana 197 mm	Shallow built-under in 197 mm
Motor de bajo consumo y ecoeficiente	Eco-efficient low consumption motor
Bajo nivel sonoro: 61 dB max	Lowest Noise levels Max 61 Db
Excelente velocidad de aspiración a 10 M/s	Excellent Airflow speed levels on top 10 M/s
Recirculación: Filtros de carbono reactivables de alta eficiencia + Filtro HEPA	Recirculation: High efficiency reactivable carbon filters + HEPA filter
Conducto rectangular trasero: 220 x 55 mm	Rear 220 x 55 mm rectangular ducting pipe (Extraction version)

### Features of the cooker hood

### Características de la placa de inducción

Stop&Go	Stop&Go
Cristal cerámico Keraspectrum	Keraspectrum Glass and E.G.O High Tech inside
Cocción automática	Automatic cooking
La función Bridge permite acoplar 2 inductores de cada lado para hacer un único conjunto	Bridge function allows coupling 2 inductors on each side to make it a unique set
Detección inteligente de recipiente	Intelligent self-pot detection
La función Chef le permite modificar la posición de la sartén dentro de la placa sin perder la potencia de calor	Chef function. Let you easily move the pan from Inductors left to right keeping the heating power level
Indicador de calor residual	Residual heat indicator
Función Booster y Doble Booster	Booster & Double Booster function
Acelerador de calor	Heating accelerator

### Features of the induction hob

### Notas / Notes

Incluye bandeja de limpieza fácil que recoge el aceite  
Includes easy-cleaning tray for collection of oils

Vista frontal / Front view

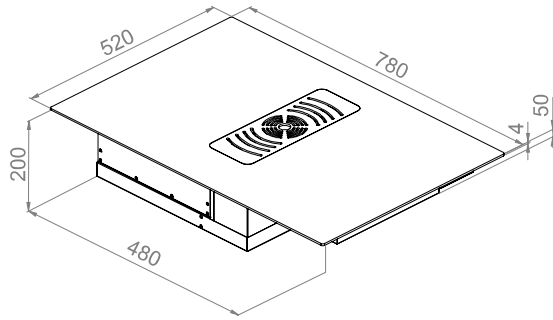

Vista Trasera / Rear view

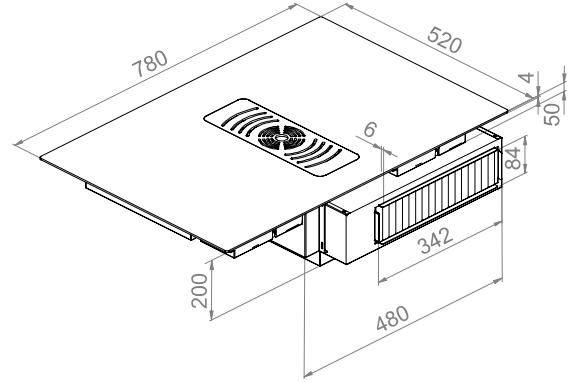

Medidas Encastre / Dimensions built in size

Instalación vidrio superpuesto  
Installation "built-in" / "built-on top"

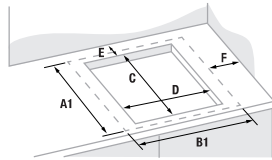

Instalación vidrio enrasado  
Installation "flushed"

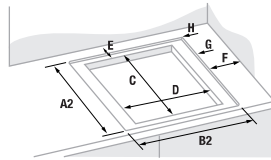

Tamaño del Vidrio Size of glass		Tamaño de Corte Size of cut		Fondo Rear	Lado Lateral	Radio Radio	Instalación en vidrio al ras Installation "flushed"		
A1	B1	C	D	E (min)	F (min)	H	A2	B2	G*
520	780	490	750	50	40	8	524	784	5

\* Profundidad/Depth

La medida exterior mínima del mueble para instalar este tipo de campana es de 900 x 560 mm.  
The minimal external dimension of furniture to install this hood should be 900 x 560 mm.

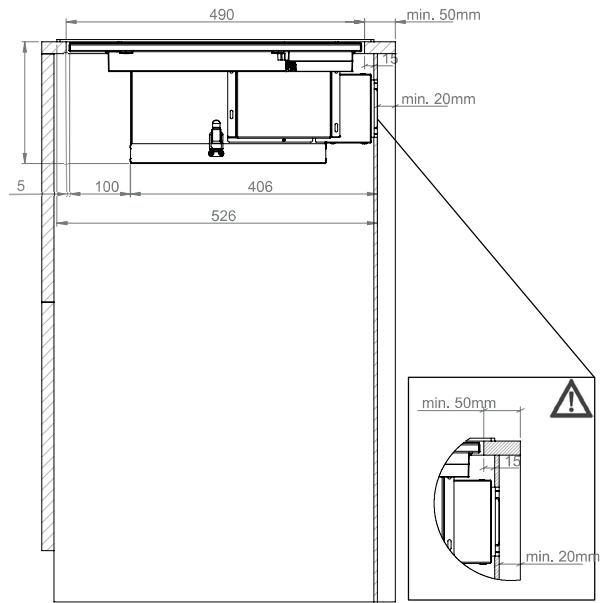

Atención: Apertura mínima para la ventilación de humos > 500 cm<sup>2</sup>  
Venting Minimum Opening > 500 cm<sup>2</sup>

Medidas de corte en trasera del mueble / Cutting measures in the back of the furniture

Vista Trasera / Rear view

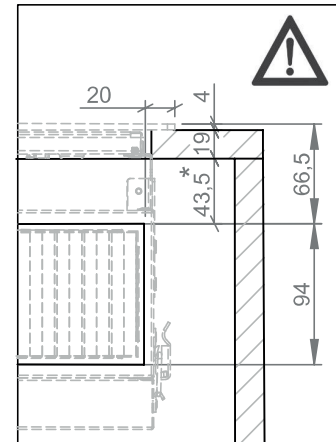
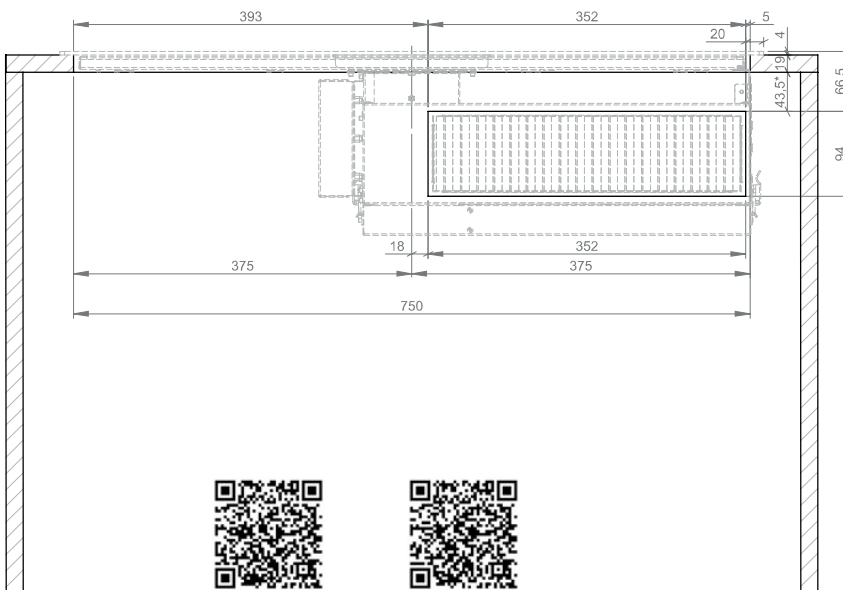

**\*Atención:**  
La cota de 43,5mm es para encimeras de grosor 19mm.  
La cota variará en función del grosor de la encimera.  
43,5mm dimension is for 19mm thick countertops.  
This dimension will change depending on the countertop thickness.





# E-320

Inox - Cristal negro  
Stainless Steel - Black glass



Mod. Inox  
Stainless steel

## SAP

Sistema anti atrapamientos Pando  
Pando Anti-Trap Safety System

Modelos / Models

### Inox / Stainless Steel

Front. (cm)	Motor	Ø tubo	Clas. Ener.	Ref.	P.V.R
<b>Motor Interior / Interior Motor</b>					
90	V.950	Ø150	A	008994	1.995 €
120	V.950	Ø150	A	009783	2.695 €
<b>Motor Intermedio exterior / Duct-in-line motor</b>					
90	V.1200	Ø150	B	008995	2.395 €
120	V.2000	Ø200	B	009784	3.395 €

### Cristal Negro / Black glass

Front. (cm)	Motor	Ø tubo	Clas. Ener.	Ref.	P.V.R
<b>Motor Interior / Interior Motor</b>					
90	V.950	Ø150	A	008998	1.995 €
120	V.950	Ø150	A	009786	2.695 €
<b>Motor Intermedio exterior / Duct-in-line motor</b>					
90	V.1200	Ø150	B	008999	2.495 €
120	V.2000	Ø200	B	009787	3.395 €

Opcionales / Options

Kits de recirculación. Ver página 210  
Activated carbon filters kit. See page 210

Notas / Notes

#### Notas para instalación con placa de gas Notes for installation with a gas hob

Distancia mínima de 50 mm entre marco exterior campana y marco exterior placa de gas.  
The minimum distance between the hood and the gas hob must be 50 mm

Potencia máxima placa de gas 12.6 kw  
Maximum power of gas hob: 12.6 Kw

Distancia mínima entre marco exterior placa de gas y marco exterior quemador de gas, consultar manual según tipo y potencia.  
Please, consult the distance form exterior part of the hob and exterior part of gas burner, according to the type and power of the hob.

Leer atentamente el manual de uso e instalación que acompaña el producto.  
Please, read attentively the installation guide of the product

#### Notas para instalación con placa inducción Notes for installation with an induction hob

Medida de 90 cm sólo para encimeras de 81 x 38 cm.  
90 cm Size only for 81 x 38 cm hobs.

Medida de 120 cm sólo para encimeras de 105 x 38 cm.  
120 cm Size only for 105 x 38 cm hobs.

Sólo recomendable en zonas de cocción compactas, no modulares.  
Only recommended for non-modular hobs.

Distancia máxima entre campana y zona de cocción de 50 mm.  
Maximum distance between hood and hob 50 mm.

Esquemas medidas / Technical Drawings

#### Motor Interior / Interior Motor

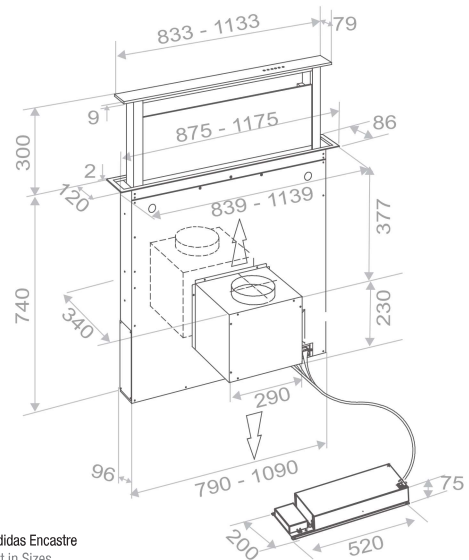

Medidas Encastre  
Built in Sizes

90 cm	100 x 842
120 cm	100 x 1142

#### Motor Intermedio exterior / Duct-in-line motor

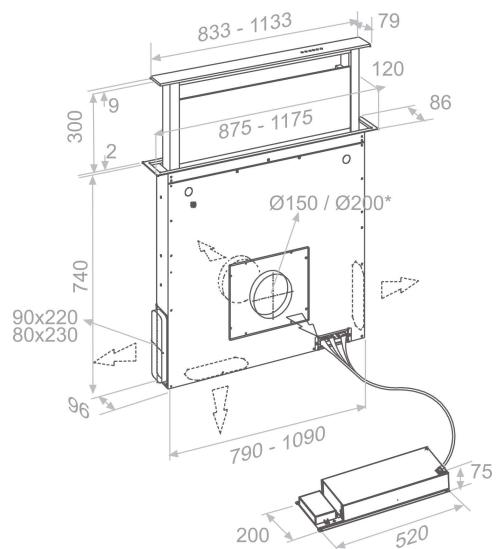

Acceso / Acces WEB



**E-320**

Integración / Integrated

# E-350

Inox texturado.  
Panel frontal Inox / Cristal Negro  
Textured Stainless Steel.  
Stainless Steel front panel / Black glass



## SAP

Sistema anti atrapamientos Pando  
Pando Anti-Trap Safety System

Modelos / Models

### Motor Interior / Motor Intermedio Exterior Interior Motor / Duct-in-line motor

Front. (cm)	Motor	Ø tubo	Clas. Ener.	Ref.	P.V.R
-------------	-------	--------	-------------	------	-------

### Panel frontal inox / Stainless Steel front panel

90	V.1350	Ø150	B	009215	2.795 €
120	V.1350 eco	Ø150	B	010327	3.475 €

### Panel frontal Cristal Negro / Black glass front panel

90	V.1350	Ø150	B	009239	2.795 €
120	V.1350 eco	Ø150	B	010328	3.475 €

Opcionales / Options

Kits de recirculación. Ver página 210  
Activated carbon filters kit. See page 210

Convertidor circular a rectangular (Ref. 640064500079)  
Transition from round to rectangular. Ref. 640064500079 40 €

Notas / Notes

### Notas generales

#### Notes

Iluminación led sólo disponible en 6000 k  
Lighting available only in LED 6000k

Extensión sobre encimera de hasta 50 cm.  
Slide up telescopic extension of up to 50 cm.

### Notas para instalación con placa inducción

#### Notes for installation with a induction hob

Para encimeras de 81 x 38 cm.  
For 81 x 38 cm hobs.

Sólo recomendable en zonas de cocción compactas, no modulares.  
Only recommended for non-modular hobs.

Distancia máxima entre campana y zona de cocción de 50 mm.  
Maximum distance between hood and hob 50 mm.

### Notas para instalación con placa de gas

#### Notes for installation with a gas hob

Distancia mínima de 50 mm entre marco exterior campana y marco exterior placa de gas.  
The minimum distance between the hood and the gas hob must be 50 mm

Potencia máxima placa de gas 11,0 kw  
Maximum power of gas hob: 11.0 Kw

Distancia mínima entre marco exterior placa de gas y marco exterior quemador de gas, consultar manual según tipo y potencia.  
Please, consult the distance from exterior part of the hob to the exterior part of gas burner, according to the type and power of the hob.

Leer atentamente el manual de uso e instalación que acompaña el producto.  
Please, read attentively the installation guide of the product

Esquemas medidas / Technical Drawings

### Motor Interior / Interior Motor

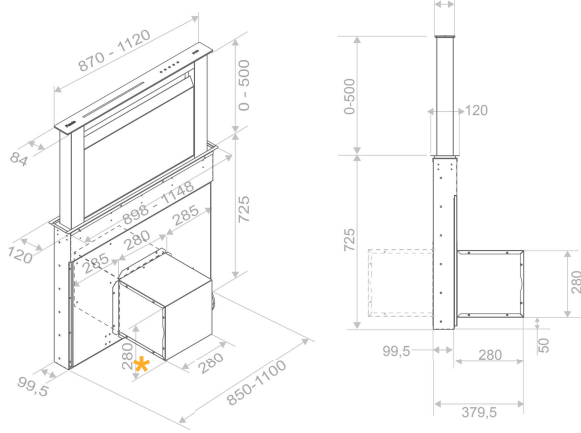

\* Box de motor con posibilidad de giro de 360°  
The motor position can be turned around 360

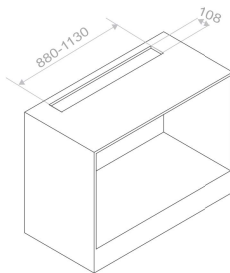

Caja motor  
Box engine

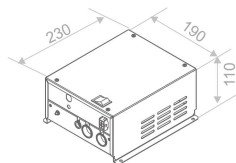
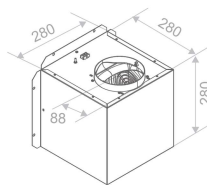

Caja de potencia  
Power box



Acceso / Acces WEB

Medidas de encastre  
Built in Sizes

90 cm	108 x 880
120 cm	108 x 1130

### Motor Intermedio exterior / Duct-in-line motor

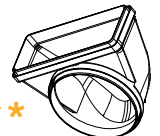
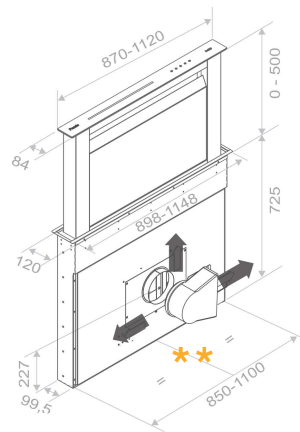

\* \* Opcional: convertidor circular a rectangular  
Options: Round to rectangular adaptor

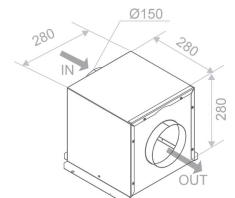
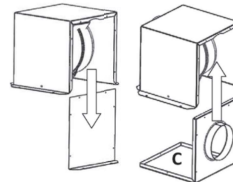

Caja motor remota  
Box remote engine

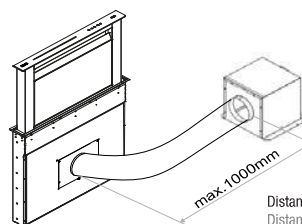

Distancia entre campana y motor  
Distance between cooker hood and motor

Integración / Integrated



Model. 90 cm



# E-350

Integración / Integrated



# integralkitchensolutions







# EVOLIKE

Estructura para Grupo EVO de pared o isla  
Structure for wall or island EVO group

## Dimensione y decore su EVOLIKE

Puede panelarse con multitud de materiales:  
madera, cristal, espejo, solid surface, losa cerámica, acero inoxidable, ...

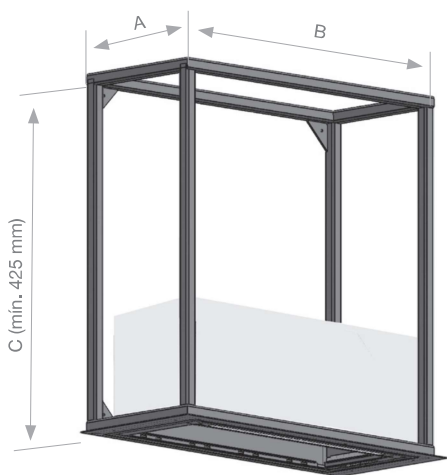

## Size and decorate your EVOLIKE

You can choose from a wide range of materials:  
wood, glass, mirrored, solid surface, ceramic tile, stainless steel and more.

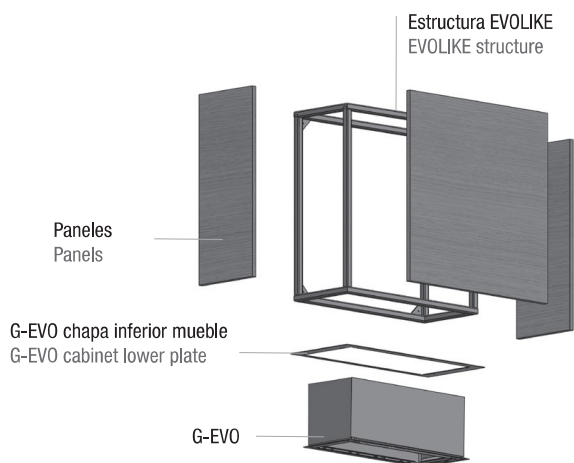

### Bajo presupuesto / On request

Este producto se suministra conjuntamente con el grupo EVO adecuado.  
(Nunca se venderá solo la estructura).  
This product is delivered together along with its EVO group accordingly.  
(The structure is never sold on its own).

Dependiendo de las medidas de la estructura, se puede suministrar con el grupo filtrante S.E.C. System.  
Can be supplied with the S.E.C. System filter set depending on the size of the structure.

### Dimensiones mínimas estándar Standard Minimum Dimensions

	A (mm)	B (mm)
EVO 58	330	670
EVO 78	330	870
EVO 94,8	330	1035
EVO 111,6	330	1200
EVO 128,5	330	1375

### EVO - Distribución filtros y luces por medidas.

EVO - Distribution of filters and lights according the size of the hood.

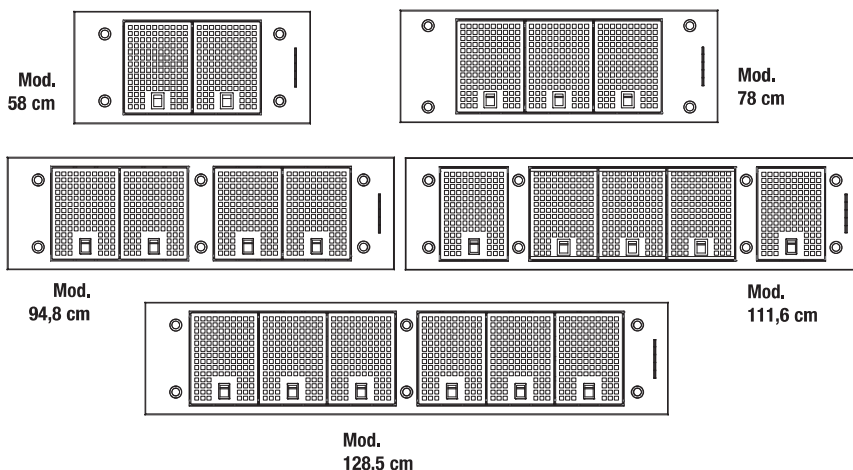

### Base INOX EVO.

Stainless Steel base for EVO

\* Cualquier variación sobre las medidas indicadas, bajo presupuesto.

\* Any variation to the above sizes, on request.

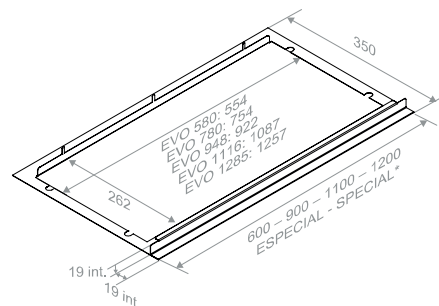

Descripción / Description	Ref.	P.V.R.
Base INOX EVO 580	009136	80 €
Base INOX EVO 780	009137	95 €
Base INOX EVO 948	009985	125 €
Base INOX EVO 1116	009986	135 €
Base INOX EVO 1285	009989	140 €



Model. 85 cm

# EVO

Inox  
Stainless Steel

58 cm  
78 cm  
94,8 cm  
111,6 cm  
128,5 cm



Modelos / Models

## S.E.C. System® Motor Interior / Interior Motor

Front. (cm)	Motor	Ø tubo	Clas. Ener.	Ref.	P.V.R
58	V.750	Ø125	B	008496	795 €
	V.850	Ø150	A+	007792	795 €
	V.1050 eco SEC® PLUS	Ø150	A+++	009615	995 €
78	V.750	Ø125	B	008498	845 €
	V.850	Ø150	A+	007379	845 €
	V.1050 eco SEC® PLUS	Ø150	A+++	009616	1.095 €
94,8	V.1250 eco	Ø150	A+++	008499	1.395 €
	V.750	Ø125	B	008500	945 €
	V.850	Ø150	A+	007796	945 €
111,6	V.1050 eco SEC® PLUS	Ø150	A+++	009618	1.195 €
	V.1250 eco	Ø150	A+++	008501	1.445 €
	V.850	Ø150	A+	007800	1.045 €
128,5	V.1050 eco SEC® PLUS	Ø150	A+	009620	1.295 €
	V.1250 eco	Ø150	A+++	008502	1.595 €
	V.850	Ø150	A+	007804	1.145 €
128,5	V.1050 eco SEC® PLUS	Ø150	A+++	009622	1.445 €
	V.1250 eco	Ø150	A+++	008503	1.745 €

## Motor Intermedio exterior / Duct-in-line motor

78	V.1550 eco	Ø150	A+	009617	1.595 €
94,8	V.1550 eco	Ø150	A+	009619	1.695 €
111,6	V.1550 eco	Ø150	A+	009621	1.895 €
128,5	V.1550 eco	Ø150	A+	009623	2.045 €

Opcionales / Options

### AirLink

Modelo compatible. Es imprescindible solicitar esta opción en el pedido de la campana. No se equipa de serie. 0 €  
Compatible Model. This option must be requested together with the purchase order. Is not included as standard.

Kits de recirculación. Ver página 210  
Activated carbon filters kit. See page 210

Cambio a LED cálido de 3000K. 0 €  
Indicar claramente en el pedido si el cambio debe realizarse en fábrica.  
LED change to warm light LED 3000K.  
Clearly indicate in the order if the change must be made at the factory.

Mando a distancia Touch. Suministrado con la campana. 120 €  
Remote Control Touch supplied together with the hood.

Opción de salida trasera. Indicar en pedido. 120 €  
Option of rear exit, has to be mentioned in the order.

Base Inox para GRUPO Filtrante. Ver página 208  
Stainless Steel base for filtering SET, see page 208

Para otras motorizaciones, consultar  
For other motor options please check

Esquemas medidas / Technical Drawings

Medidas de encastre Built in Sizes	
58	262 x 554
78	262 x 754
95	262 x 922
111,6	262 x 1087
128,5	262 x 1257

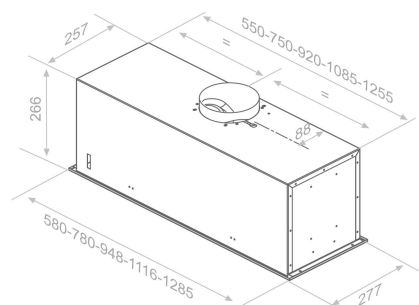

Acceso / Acces WEB



# PRO

Inox  
Stainless Steel

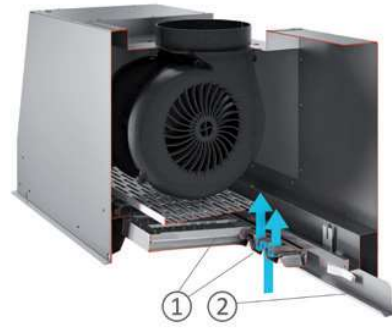
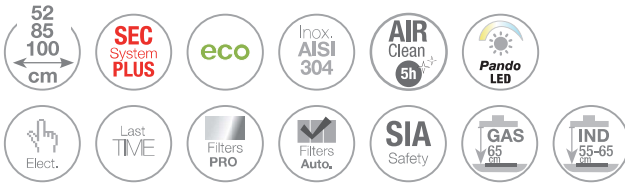

Modelos / Models

## S.E.C. System® Motor Interior / Interior Motor

Front. (cm)	Motor	Ø tubo	Clas. Ener.	Ref.	P.V.R
52	V.850	Ø150	A+	009726	895 €
	V.1050 eco SEC® PLUS	Ø150	A+	010026	1.145 €
85	V.850	Ø150	A+	009727	995 €
	V.1050 eco SEC® PLUS	Ø150	A+	010027	1.245 €
	V.1250 eco	Ø150	A++	010078	1.395 €
100	V.850	Ø150	A+	009831	1.195 €
	V.1050 eco SEC® PLUS	Ø150	A+	010077	1.395 €
	V.1250 eco	Ø150	A++	010079	1.495 €

Opcionales / Options

### AirLink

Modelo compatible. Es imprescindible solicitar esta opción en el pedido de la campana. No se equipa de serie 0 €  
Compatible Model. This option must be requested together with the purchase order. Is not included as standard.

Kits de recirculación. Ver página 210  
Activated carbon filters kit. See page 210

El motor V.1050 no puede incorporar filtros de carbón  
V.1050eco motor cannot incorporate Carbon Filters

Mando a distancia Touch. Suministrado con la campana. 120 €  
Remote Control Touch supplied together with the hood.

Base Inox para GRUPO Filtrante. Ver página 208  
Stainless steel base for filtering SET, see page 208

Notas / Notes

### AirClean

Sistema automático de funcionamiento del motor 10 min. cada hora durante 5 horas.  
Automatic working motor system for 10 minutes every hour during 5 hours.

Incorpora bandeja de fácil limpieza que recoge las grasas de la cocción de los filtros.  
Includes easy-cleaning tray for collection of oils.

Salida de humos superior o trasera  
Top of back fume outlet

### Base INOX PRO Stainless Steel base for PRO

\* Cualquier variación sobre las medidas indicadas, bajo presupuesto.  
\* Any variation to the above sizes, on request.

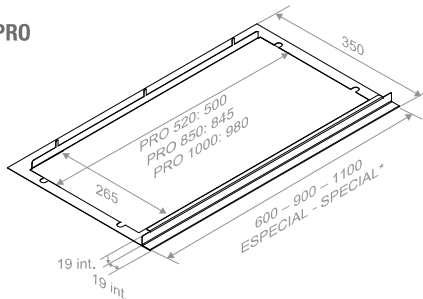

Descripción / Description	Ref.	P.V.R.
Base INOX PRO 520	9823	80 €
Base INOX PRO 850	9824	95 €
Base INOX PRO 1000	9987	135 €

1

**Filtros profesionales:** su forma estilo laberinto permite el paso del aire a la vez que ayuda a condensar las partículas de grasa, liberando al motor de estas suciedades lo que permite que trabaje con menos desgaste y consigue un aumento de la vida útil del mismo. Su fabricación en acero inoxidable de primera calidad hace que sea prácticamente impenetrable para la grasa y le proporciona una durabilidad ilimitada. Los filtros pueden limpiarse fácilmente incluso en lavavajillas, manteniéndose siempre como nuevos.

**Professional filters:** their maze-type design allows air to pass through while helping to condense grease particles, keeping this dirt out of the motor and so reducing wear and tear and prolonging the working life of the motor. The fact that it is made of top-quality stainless steel means it is practically impenetrable by grease and gives it unlimited durability.

2

**Bandeja recoge-grasas:** recoge las grasas filtradas permitiendo una fácil limpieza y mantenimiento de la campana extractora, a la vez que impide cualquier posible goteo en la zona de cocción. La bandeja es desmontable para su perfecto mantenimiento.

**Grease tray:** includes a removable tray to pick up any drops of grease that might have accumulated in the hood to ensure easy a cleaning and maintenance.

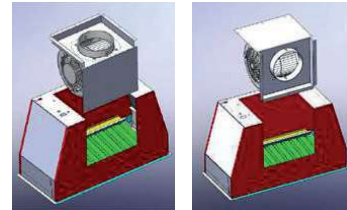

3

**Salida de humos adaptable:** El tubo de salida de humos puede ser vertical o por la parte trasera, facilitando la adaptación a diferentes proyectos sin tener que cambiar de grupo filtrante. Esta acción la puede realizar fácilmente el instalador.

**Adaptable fume outlet:** The fume outlet flue can be vertical or through the back, making it easier to adapt for different projects without having to change the filter unit. This can be done easily by the installer.

Esquemas medidas / Technical Drawings

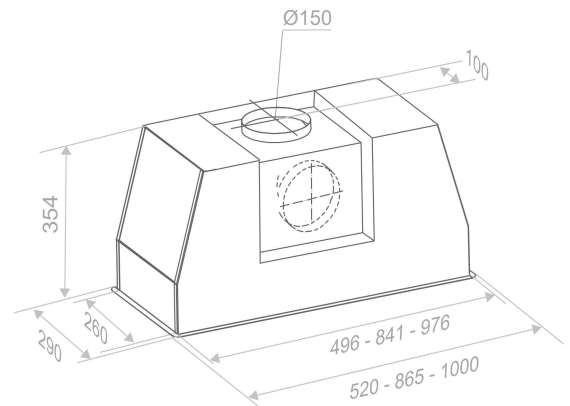

Dimensiones de encastre  
Built in Sizes

52	265 x 501
85	265 x 846
100	265 x 981



Acceso / Acces WEB



Model. 52 cm



**PRO**

Integración / Integrated

# NCR

Inox - Cristal negro o blanco  
Stainless Steel - Black or white glass



Modelos / Models

## S.E.C. System® Motor Interior / Interior Motor

Front. (cm)	Motor	Ø tubo	Clas. Ener.	Ref.	P.V.R
<b>Cristal blanco - White Glass</b>					
52	V.850	Ø150	A	009131	675 €
78	V.850	Ø150	A	009132	755 €
111	V.850	Ø150	A	009169	1.095 €
<b>Cristal negro - Black Glass</b>					
52	V.850	Ø150	A	010044	725 €
78	V.850	Ø150	A	010045	795 €
111	V.850	Ø150	A	010062	1.175 €

Opcionales / Options

### AirLink

Modelo compatible. Es imprescindible solicitar esta opción en el pedido de la campana. No se equipa de serie  
Compatible Model. This option must be requested together with the purchase order. Is not included as standard.

0 €

Cambio LED original a LED cálido de 3000K. Suministrado con la campana.  
LED change to warm light LED 3000K. Available only at the factory

60 €

Mando a distancia Touch. Suministrado con la campana.  
Remote control Touch supplied together with the hood.

0 €

Kits de recirculación. Ver página 210  
Activated carbon filters kit. See page 210

Base inox para Grupo Filtrante. Ver página 208  
Stainless steel base for filtering SETS. See page 208

Esquemas medidas / Technical Drawings

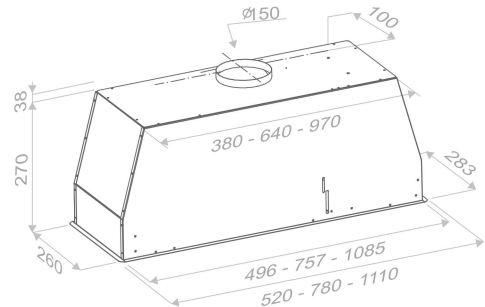

## Base INOX NCR Stainless Steel base for NCR

\* Cualquier variación sobre las medidas indicadas, bajo presupuesto.  
\* Any variation to the above sizes, on request.

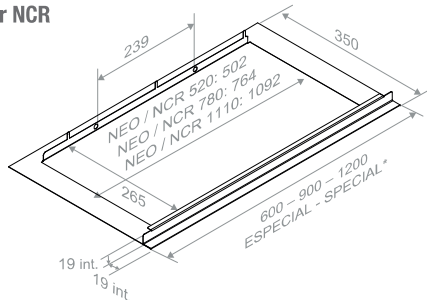

Descripción / Description	Ref.	P.V.R.
Base INOX NEO / NCR 520	9138	80 €
Base INOX NEO / NCR 780	9139	95 €
Base INOX NCR 1110	10080	135 €

Medidas de encastre  
Built in Sizes

52	265 x 502
78	265 x 764
111	265 x 1092



Acceso / Acces WEB

Integración / Integrated



Model. 78 cm. RAL 9005. TOTAL BLACK



Model. 78 cm



**NCR**





Modelos / Models

## Inox / Stainless Steel

### Motor Interior / Interior Motor

Front. (cm)	Motor	Ø tubo	Clas. Ener.	Ref.	P.V.R
51	V.750	Ø125	B	010136	775 €
	V.1050 eco SEC® PLUS	Ø150	A++	010138	990 €
72.5	V.750	Ø125	B	010139	895 €
	V.850	Ø150	A+	010140	895 €
	V.1050 eco SEC® PLUS	Ø150	A++	010141	1.145 €
81	V.1250 eco	Ø150	A++	010142	1.345 €
	V.850	Ø150	A+	010145	895 €
	V.1050 eco SEC® PLUS	Ø150	A++	010146	1.195 €
	V.1250 eco	Ø150	A++	010147	1.395 €
111	V.850	Ø150	A+	010149	995 €
	V.1050 eco SEC® PLUS	Ø150	A++	010150	1.295 €
128	V.1250 eco	Ø150	A++	010151	1.595 €
	V.850	Ø150	A+	010153	1.145 €
	V.1250 eco	Ø150	A++	010155	1.745 €

### Motor Intermedio exterior / Duct-in-line motor

72.5	V.1550 eco	Ø150	A+	010143	1.795 €
81	V.1550 eco	Ø150	A+	010148	1.825 €

## Negro / Black

### Motor Interior / Interior Motor

51	V.750	Ø125	B	010157	795 €
	V.1050 eco SEC® PLUS	Ø150	A++	010159	1.065 €
72.5	V.750	Ø125	B	010160	945 €
	V.850	Ø150	A+	010161	945 €
	V.1050 eco SEC® PLUS	Ø150	A++	010162	1.195 €
81	V.1250 eco	Ø150	A++	010163	1.395 €
	V.850	Ø150	A+	010166	995 €
	V.1050 eco SEC® PLUS	Ø150	A++	010167	1.295 €
	V.1250 eco	Ø150	A++	010168	1.495 €
111	V.850	Ø150	A+	010170	1.125 €
	V.1050 eco SEC® PLUS	Ø150	A++	010171	1.395 €
128	V.1250 eco	Ø150	A++	010172	1.595 €
	V.850	Ø150	A+	010174	1.245 €
	V.1250 eco	Ø150	A++	010176	1.695 €

### Motor Intermedio exterior / Duct-in-line motor

72.5	V.1550 eco	Ø150	A+	010164	1.795 €
81	V.1550 eco	Ø150	A+	010169	1.895 €

Opcionales / Options

### AirLink

Modelo compatible. Es imprescindible solicitar esta opción en el pedido de la campana. No se equipa de serie. 0 €  
Compatible Model. This option must be requested together with the purchase order. Is not included as standard.

Mando a distancia Touch. Suministrado con la campana. 120 €  
Remote control Touch supplied together with the hood.

Esquemas medidas / Technical Drawings

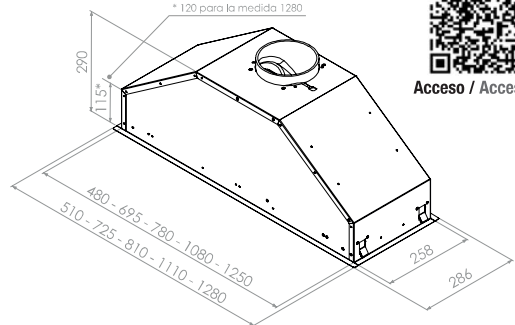

Acceso / Acces WEB

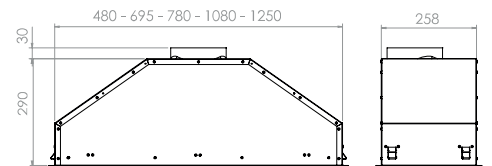

Medidas de encastre Built in Sizes	
510	490 x 268
725	705 x 268
810	790 x 268
1110	1090 x 268
1280	1260 x 268

### Base GTI / Base for GTI

\* Cualquier variación sobre las medidas indicadas, bajo presupuesto.  
\* Any variation to the above sizes, on request.

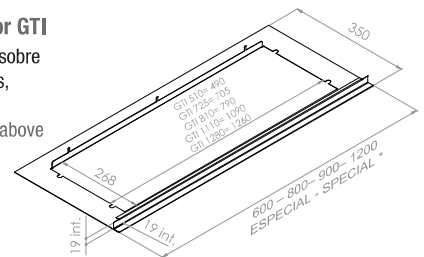

Base	Ref.	P.V.R.	Base	Ref.	P.V.R.
INOX/S.S. GTI 510	010203	88 €	NEGRA/BLACK GTI 510	010226	100 €
INOX/S.S. GTI 725	010204	105 €	NEGRA/BLACK GTI 725	010227	120 €
INOX/S.S. GTI 810	010205	116 €	NEGRA/BLACK GTI 810	010228	130 €
INOX/S.S. GTI 1.110	010206	149 €	NEGRA/BLACK GTI 1.110	010229	165 €
INOX/S.S. GTI 1.280	010207	154 €	NEGRA/BLACK GTI 1.280	010230	175 €

Distribución filtros y luces por medidas.  
Distribution of filters and lights according the size of the hood.

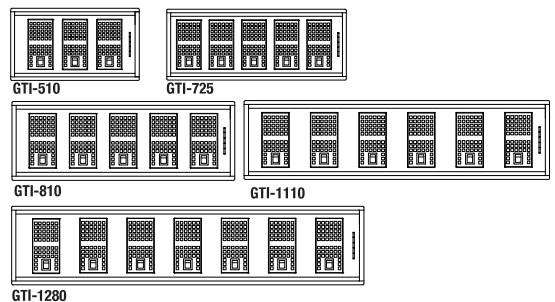



Model. Inox (81 cm)



Model. Negro / Black (81 cm)



Model. Total Black (81 cm)



**Filtros tintados en Negro - Black tinted filters**

Front. (cm)	Filtros por grupo filtrante Filters by filter group	P.V.R	Front. (cm)	Filtros por grupo filtrante Filters by filter group	P.V.R
51	3 Unidades / 3 Units	35 €*	111	6 Unidades / 6 Units	70 €*
72,5	5 Unidades / 5 Units	60 €*	128	7 Unidades / 6 Units	80 €*
81	5 Unidades / 5 Units	60 €*			

(\*) Incremento de precio sobre el P.V.R del Grupo Filtrante correspondiente  
Price increase over the P.V.R of the corresponding Filtering Group



# GRV Inox Stainless Steel



Modelos / Models

## S.E.C. System® Motor Interior / Interior Motor

Front. (cm)	Motor	Ø tubo	Clas. Ener.	Ref.	P.V.R
52	V.850	Ø150	A	010002	825 €
78	V.850	Ø150	A	010003	945 €

## Base INOX GRV Stainless Steel base for GRV

\* Cualquier variación sobre las medidas indicadas, bajo presupuesto.  
\* Any variation to the above sizes, on request.

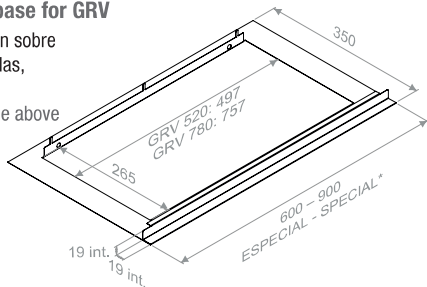

Descripción / Description	Ref.	P.V.R.
Base INOX GRV 520	010118	80 €
Base INOX GRV 780	010119	95 €

Esquemas medidas / Technical Drawings

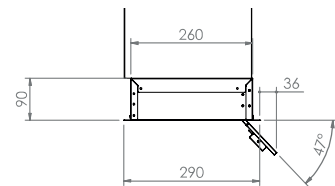
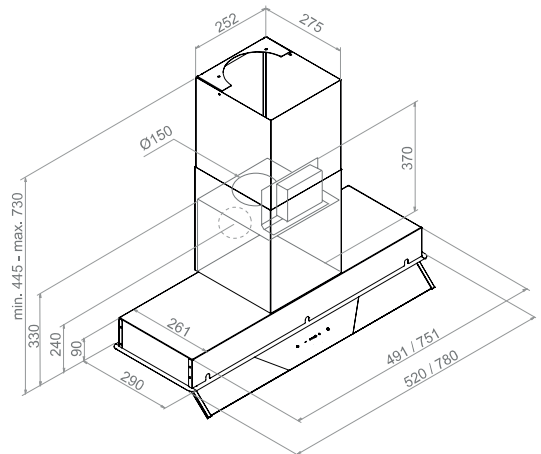

Medidas encastre  
Built in Sizes

52	497 x 265
78	757 x 265



Acceso / Acces WEB

Opcionales / Options

Kits de recirculación. Ver página 210  
Activated carbon filters kit. See page 210

Opción de cambio a LED de luz cálida de 3200K. Suministrado con la campana.  
LED change to warm light LED 3200K. Available only at the factory.

0 €

Base inox para Grupo Filtrante. Ver página 208  
Stainless steel base for filtering SETS. See page 208



## NEO Inox Stainless Steel



### S.E.C. System® Motor Interior / Interior Motor

Front. (cm)	Motor	Ø tubo	Clas. Ener.	Ref.	P.V.R
52	V.850	Ø150	A+	009009	495 €
78	V.850	Ø150	A+	009010	550 €

Opcionales / Options	Precio
Filtro inoxidable. Precio unitario Stainless steel filter. Unit price	39 €
Kits de recirculación. Ver página 210 Activated carbon filters kit. See page 210	
Opción de cambio a LED de luz cálida de 3000K. Suministrado con la campana. LED change to warm light LED 3000K. Available only at the factory.	80 €
Mando a distancia electrónico. Suministrado con la campana. Electronic remote control (only for Inox model). Available only at the factory.	70 €
Base inox para Grupo Filtrante. Ver página 208 Stainless steel base for filtering SETS. See page 208	

**AirClean**  
Sistema automático de funcionamiento del motor 10 min. cada hora durante 5 horas.  
Automatic working motor system for 10 minutes every hour during 5 hours.



Esquemas medidas / Technical Drawings

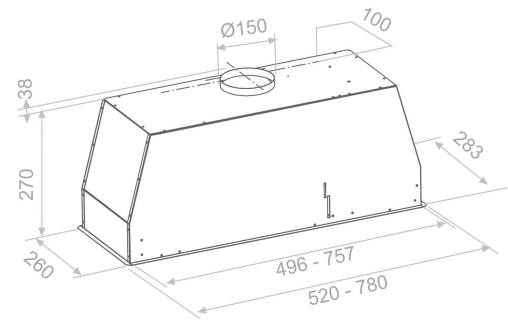

Medidas Encastre  
Built in Sizes

52	265 x 502
78	265 x 764



Acceso / Acces WEB

### Base INOX NEO Stainless Steel base for NEO

\* Cualquier variación sobre las medidas indicadas, bajo presupuesto.

\* Any variation to the above sizes, on request.

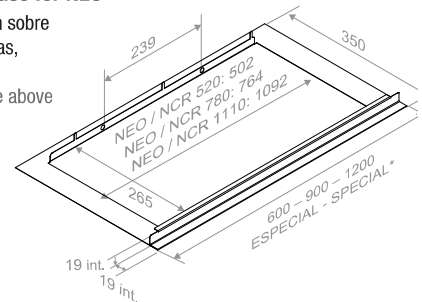

Descripción / Description	Ref.	P.V.R.
Base INOX NEO / NCR 520	9138	80 €
Base INOX NEO / NCR 780	9139	95 €
Base INOX NCR 1110	10080	135 €

Integración / Integrated





# TIB

Inox - Cristal  
Stainless Steel - Glass

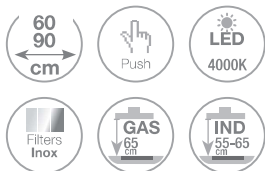

Modelos / Models

### Motor Interior / Interior Motor

Front. (cm)	Motor	Ø tubo	Clas. Ener.	Ref.	P.V.R
60	V.730	Ø120	A	009908	495 €
90	V.730	Ø120	A	009909	525 €

Opcionales / Options

Kits de recirculación. Ver página 210  
Activated carbon filters kit. See page 210

Cambio LED original a LED cálido de 3000K. Suministrado con la campana.  
LED change to warm light LED 3000K. Available only at the factory. 80 €

Esquemas medidas / Technical Drawings

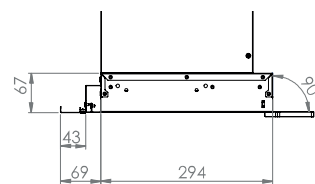
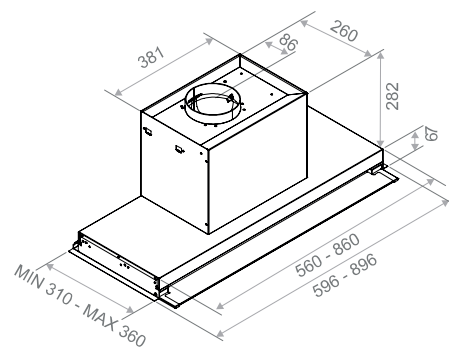

Visera abierta  
Visor open



Acceso / Acces WEB



## TIM Inox - Cristal Stainless Steel - Glass

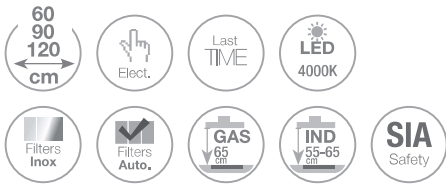

Modelos / Models

### S.E.C. System® Motor Interior / Interior Motor

Front. (cm)	Motor	Ø tubo	Clas. Ener.	Ref.	P.V.R
60	V.750	Ø120	B	009791	745 €
	V.850	Ø150	A+	009792	745 €
90	V.750	Ø120	B	009793	770 €
	V.850	Ø150	A+	009794	770 €
120	V.850	Ø150	A	009795	990 €

Opcionales / Options

### AirLink

Modelo compatible. Es imprescindible solicitar esta opción en el pedido de la campana. No se equipa de serie  
Compatible Model. This option must be requested together with the purchase order. Is not included as standard.

Kits de recirculación. Ver página 210  
Activated carbon filters kit. See page 210

Substitución de LED original por el Sistema Pando LED  
Change of the original LED to the Pando LED system



80 €

Mando a distancia Touch. Suministrado con la campana  
Remote control Touch supplied together with the hood.

120 €

Juego de tubos hasta altura total de 1400 mm  
Set of chimneys to a total height of 1400 mm

195 €

Esquemas medidas / Technical Drawings

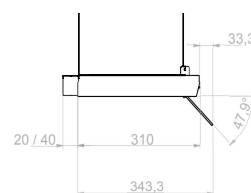
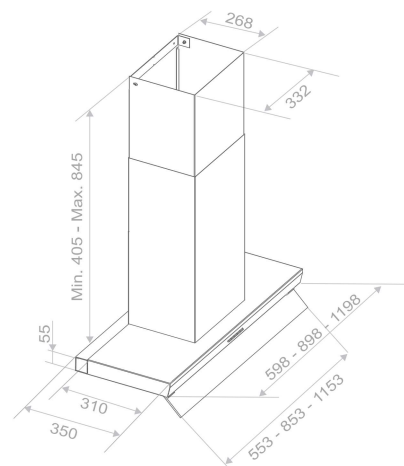

Visera abierta  
Visor open



Acceso / Acces WEB

Integración / Integrated

# TIM-2

Inox - Negro - Cristal  
Stainless Steel - Black - Glass

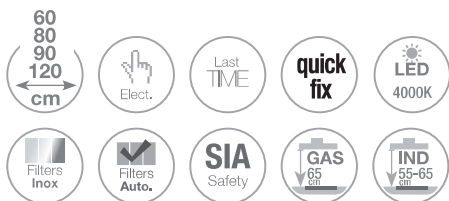

Modelos / Models

## S.E.C. System® Motor Interior / Interior Motor

Front. (cm)	Motor	Ø tubo	Clas. Ener.	Ref.	P.V.R
<b>Inox / Stainless Steel</b>					
60	V.750	Ø120	C	010122	745 €
	V.850	Ø150	A+	010123	745 €
80	V.750	Ø120	C	010134	770 €
	V.850	Ø150	A+	010135	770 €
90	V.750	Ø120	C	010124	795 €
	V.850	Ø150	A+	010125	795 €
120	V.850	Ø150	A+	010126	990 €
<b>Negro / Black</b>					
60	V.750	Ø120	C	010178	745 €
	V.850	Ø150	A+	010179	745 €
80	V.750	Ø120	C	010180	770 €
	V.850	Ø150	A+	010181	770 €
90	V.750	Ø120	C	010182	795 €
	V.850	Ø150	A+	010183	795 €
120	V.850	Ø150	A+	010184	990 €

Opcionales / Options

### AirLink

Modelo compatible. Es imprescindible solicitar esta opción en el pedido de la campana. No se equipa de serie. 0 €  
Compatible Model. This option must be requested together with the purchase order. Is not included as standard.

Kits de recirculación. Ver página 210  
Activated carbon filters kit. See page 210

Substitución de LED original por el Sistema Pando LED  
Change of the original LED to the Pando LED system 80 €

Mando a distancia Touch. Suministrado con la campana.  
Remote control Touch supplied together with the hood. 120 €

Juego de tubos  
Set of chimneys 70 €

Esquemas medidas / Technical Drawings



Sistema de fácil instalación. Ver pág. 13  
Easy installation system. See page 13

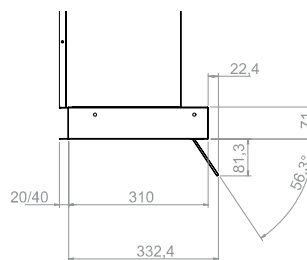
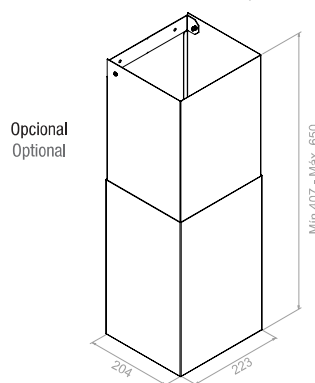
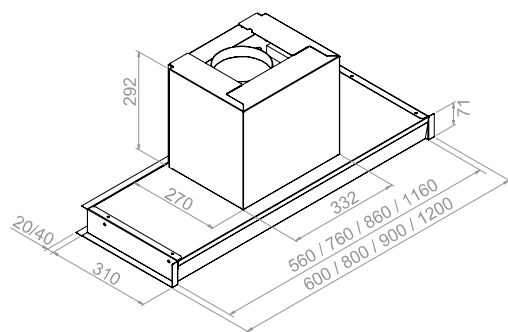

Visera abierta  
Visor open



Acceso / Acces WEB



**TIM-2**

Integración / Integrated



# TIX

Inox Antracita - Cristal  
Anthracite Stainless Steel - Glass

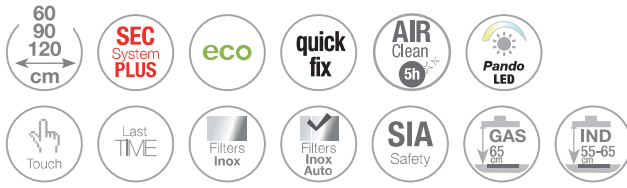

Modelos / Models

### S.E.C. System® Motor Interior / Interior Motor

Front. (cm)	Motor	Ø tubo	Clas. Ener.	Ref.	P.V.R
<b>Antracita / Anthracite</b>					
60	V.750	Ø120	B	010345	990 €
	V.850	Ø150	A	010346	990 €
	V.1050 eco SEC® PLUS	Ø150	A+	010347	1.195 €
90	V.750	Ø120	B	010348	1.095 €
	V.850	Ø150	A	010349	1.095 €
	V.1050 eco SEC® PLUS	Ø150	A+	010350	1.295 €
	V.1250 eco	Ø150	A+	010351	1.495 €
120	V.850	Ø150	A	010353	1.325 €
	V.1050 eco SEC® PLUS	Ø150	A	010354	1.525 €
	V.1250 eco	Ø150	A+	010355	1.725 €
<b>Inox / Stainless Steel</b>					
60	V.750	Ø120	B	010356	1.095 €
	V.850	Ø150	A	010357	1.095 €
	V.1050 eco SEC® PLUS	Ø150	A+	010358	1.295 €
90	V.750	Ø120	B	010359	1.195 €
	V.850	Ø150	A	010360	1.195 €
	V.1050 eco SEC® PLUS	Ø150	A+	010361	1.395 €
	V.1250 eco	Ø150	A+	010362	1.595 €
120	V.850	Ø150	A	010364	1.445 €
	V.1050 eco SEC® PLUS	Ø150	A	010365	1.645 €
	V.1250 eco	Ø150	A+	010366	1.895 €



Esquemas medidas / Technical Drawings



Sistema de fácil instalación. Ver pág. 13  
Easy installation system. See page 13

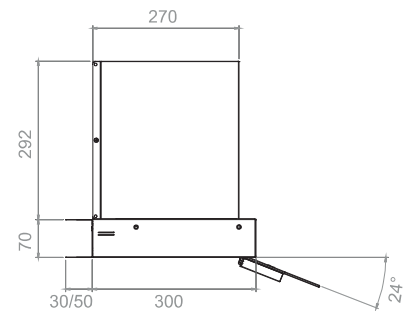
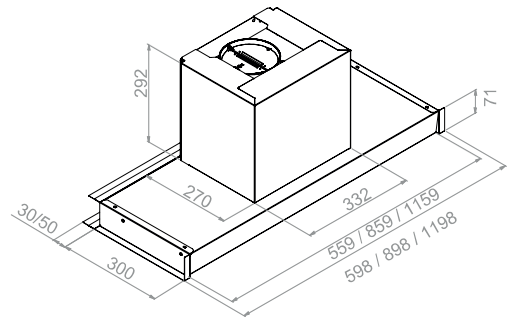

Opcionales / Options

#### AirLink

Modelo compatible. Es imprescindible solicitar esta opción en el pedido de la campana. No se equipa de serie. 0 €  
Compatible Model. This option must be requested together with the purchase order. Is not included as standard.

Kits de recirculación. Ver página 210  
Activated carbon filters kit. See page 210

El mando a distancia Touch podrá ser suministrado únicamente bajo pedido con la campana. 120 €  
Remote control can be supplied only on request with the cooker hood.

Juego de tubos hasta altura total de 940 mm 70 €  
Set of chimneys to a total height of 940 mm

Notas / Notes

#### AirClean

Sistema automático de funcionamiento del motor 10 min. cada hora durante 5 horas.  
Automatic working motor system for 10 minutes every hour during 5 hours.



Acceso / Acces WEB



Model. 90 cm

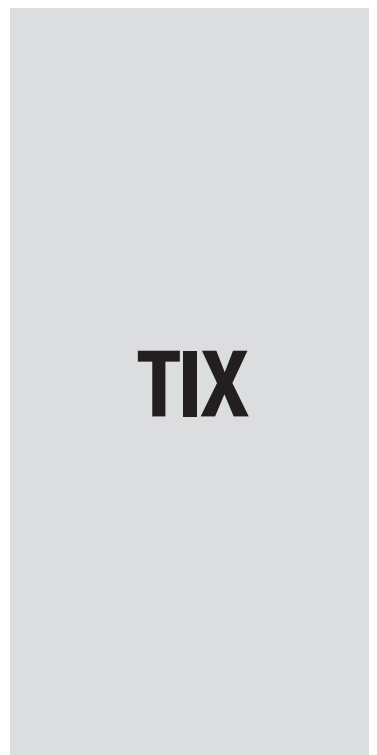

Integración / Integrated



# BGF S.E.C. System Inox Stainless Steel



Modelos / Models

## S.E.C. System® Motor Interior / Interior Motor

Front. (cm)	Motor	Ø tubo	Clas. Ener.	Ref.	P.V.R
50	V.750	Ø125	B	008504	795 €
	V.850	Ø150	A	006810	795 €
	V.1050 <i>eco</i>	Ø150	A+	009671	995 €
75	V.750	Ø125	B	008508	875 €
	V.850	Ø150	A	006811	875 €
	V.1050 <i>eco</i>	Ø150	A+	009624	1.095 €
	V.1250 <i>eco</i>	Ø150	A++	008509	1.295 €
99	V.750	Ø125	B	008512	995 €
	V.850	Ø150	A	006812	995 €
	V.1050 <i>eco</i>	Ø150	A+	009628	1.195 €
	V.1250 <i>eco</i>	Ø150	A+	008513	1.395 €
124	V.850	Ø150	A	006813	1.095 €
	V.1250 <i>eco</i>	Ø150	A++	008516	1.495 €

## Motor Intermedio exterior / Duct-in-line motor

75	V.1550 <i>eco</i>	Ø150	A+	009625	1.495 €
	V.1550 <i>eco</i>	Ø150	A+	009629	1.595 €
99	V.2450 <i>eco</i>	Ø200	A+	009631	1.995 €
124	V.1550 <i>eco</i>	Ø150	A+	009635	1.695 €
	V.2450 <i>eco</i>	Ø200	A+	009637	2.095 €

## Motor de tejado / Remote motor -Roof Outdoor

99	V.2350 <i>eco</i>	Ø200	A+	009632	2.095 €
124	V.2350 <i>eco</i>	Ø200	A+	009638	2.195 €

Esquemas medidas / Technical Drawings

**Profundidad 460 mm**  
Depth 460 mm

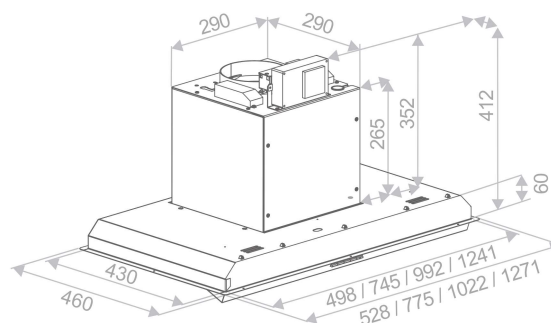

Medidas Encastre  
Built in Sizes

50	502 x 437
75	750 x 437
99	997 x 437
124	1245 x 437



Acceso / Acces WEB

Opcionales / Options

### AirLink

Modelo compatible. Es imprescindible solicitar esta opción en el pedido de la campana. No se equipa de serie. 0 €  
Compatible Model. This option must be requested together with the purchase order. Is not included as standard.

Kits de recirculación. Ver página 210  
Activated carbon filters kit. See page 210

Cambio LED original a LED cálido de 3000K. Suministrado con la campana. 80 €  
LED change to warm light LED 3000K. Available only at the factory.

Mando a distancia Touch. Suministrado con la campana. 120 €  
Remote Touch Control supplied together with the hood.

Integración / Integrated



# PGF **Inox** Stainless Steel



## Modelos / Models

### S.E.C. System® Motor Interior / Interior Motor

Front. (cm)	Motor	Ø tubo	Clas. Ener.	Ref.	P.V.R
60	V.730	Ø120	A	009954	475 €
70	V.730	Ø120	A	009955	495 €

## Opcionales / Options

Kits de recirculación. Ver página 210  
Activated carbon filters kit. See page 210

Cambio a LED de luz cálida de 3000K. Suministrado con la campana.  
LED change to warm light LED 3000K. Available only at the factory. 80 €

## Esquemas medidas / Technical Drawings

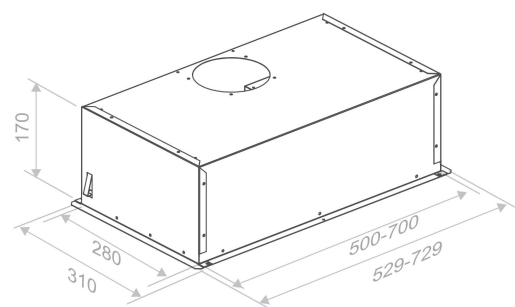

Medidas encastre  
Built in Sizes

60	505 x 285
70	705 x 285



Acceso / Acces WEB



# GIM

Inox - Frontal panelable  
Stainless Steel - panelable Front.

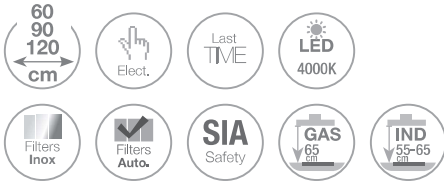

Modelos / Models

## GIM2

### S.E.C. System®

#### Motor Interior / Interior Motor

Front. (cm)	Motor	Ø tubo	Clas. Ener.	Ref.	P.V.R
60	V.850	Ø150	A	008616	795 €
90	V.850	Ø150	A	007966	895 €
120	V.850	Ø150	A	007969	1.195 €

## GIM3

### S.E.C. System®

#### Motor Interior / Interior Motor

Front. (cm)	Motor	Ø tubo	Clas. Ener.	Ref.	P.V.R
90	V.850	Ø150	A	009166	895 €

Opcionales / Options

### AirLink

Modelo compatible. Es imprescindible solicitar esta opción en el pedido de la campana. No se equipa de serie. 0 €  
Compatible Model. This option must be requested together with the purchase order. Is not included as standard.

Kits de recirculación. Ver página 210  
Activated carbon filters kit. See page 210

Cambio a LED cálido de 3000K. Suministrado con la campana. 80 €  
LED change to warm light LED 3000K. Available only at the factory.

Mando a distancia Touch. Suministrado con la campana. 120 €  
Remote Touch Control supplied together with the hood.

Opción de salida trasera. Indicar en pedido. 120 €  
Option of rear exit, has to be mentioned in the order.

Notas / Notes

Incluye de serie perfil protector para la puerta del mueble.  
Includes profile protector as standard for the door.

Incorpora bandeja de fácil limpieza que recoge las grasas de la cocción de los filtros.  
Includes easy-cleaning tray for collection of oils.

Consultar ficha técnica de herrajes para peso máximo y medidas recomendables de la puerta panelable.  
See hardware technology sheet for maximum weight and sizes recommended for the panel.

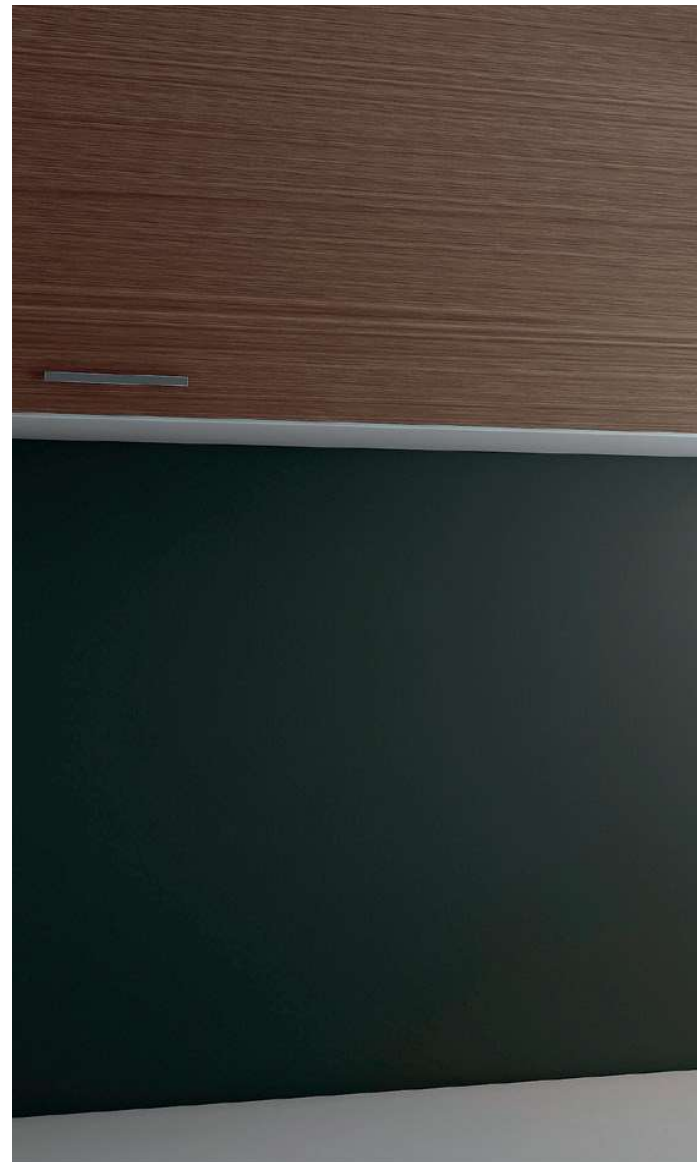

Esquemas medidas / Technical Drawings

## GIM-2

Altura / Height: 390 mm  
Fondo / Depth: 325 mm

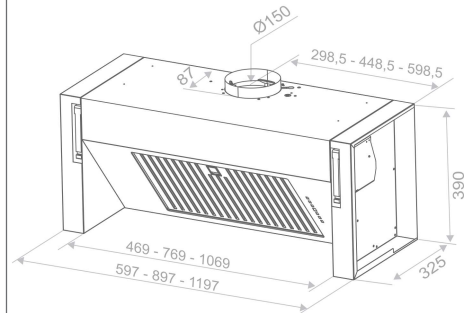

## GIM-3

Altura / Height: 360 mm  
Fondo / Depth: 325 mm

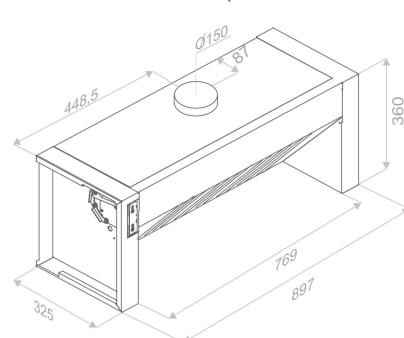

Acceso / Acces WEB



Model. 90 cm



Model. 120 cm

# GIM

Integración / Integrated



# GIT

Inox  
Stainless Steel



Modelos / Models

### S.E.C. System® Motor Interior / Interior Motor

Front. (cm)	Motor	Ø tubo	Clas. Ener.	Ref.	P.V.R
60	V.750	Ø125	B	009011	740 €
	V.850	Ø150	A+	009012	740 €

Esquemas medidas / Technical Drawings

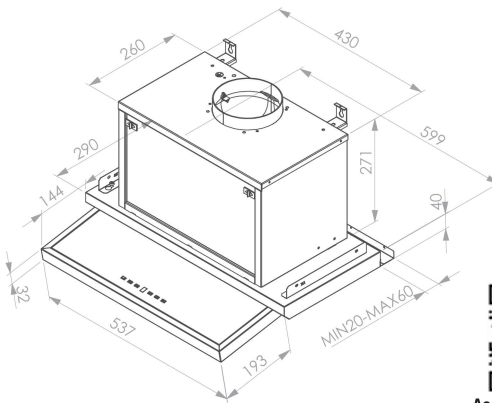
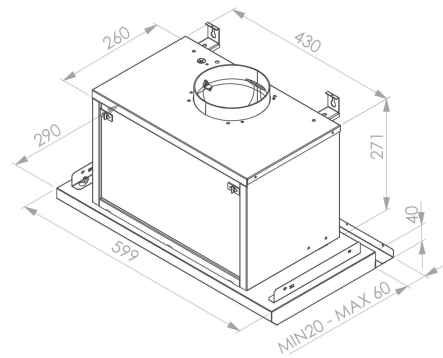

Opcionales / Options

Kits de recirculación. Ver página 210  
Activated carbon filters kit. See page 210

Cambio a LED cálido de 3000K. Suministrado con la campana. 60 €  
LED change to warm light LED 3000K. Available only at the factory.



Acceso / Acces WEB



Model. 60 cm

# ES

Inox  
Stainless Steel

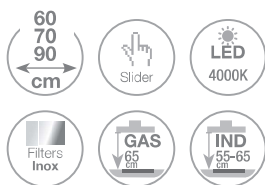

Modelos / Models

### S.E.C. System® Motor Interior / Interior Motor

Front. (cm)	Motor	Ø tubo	Clas. Ener.	Ref.	P.V.R
60	V.730	Ø120	A	009956	415 €
70	V.730	Ø120	A	009957	450 €
90	V.730	Ø120	A	009958	495 €

Opcionales / Options

Kits de recirculación. Ver página 210  
Activated carbon filters kit. See page 210

Cambio a LED cálido de 3000K. Suministrado con la campana.  
LED change to warm light LED 3000K. Available only at the factory. 60 €

Esquemas medidas / Technical Drawings

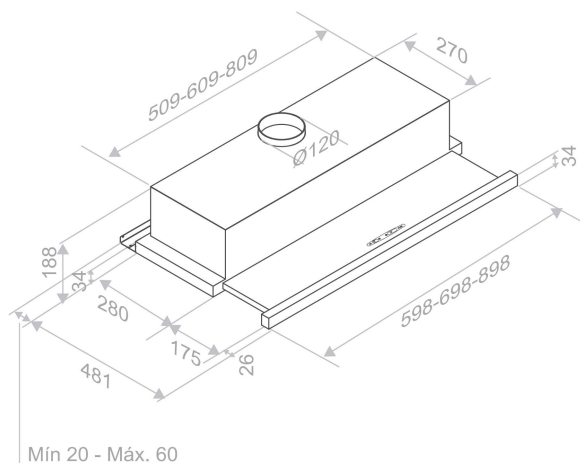

Acceso / Acces WEB





# IES S.E.C. System Inox Stainless Steel



### Modelos / Models

#### S.E.C. System® Motor Interior / Interior Motor

Front. (cm)	Motor	Ø tubo	Clas. Ener.	Ref.	P.V.R
60	V.850	Ø150	A	006211	525 €
90	V.850	Ø150	A	006212	630 €

### Opcionales / Options

Kits de recirculación. Ver página 210  
Activated carbon filters kit. See page 210

Cambio a LED cálido de 3000K. Suministrado con la campana.  
LED change to warm light LED 3000K. Available only at the factory. 80 €

### Esquemas medidas / Technical Drawings

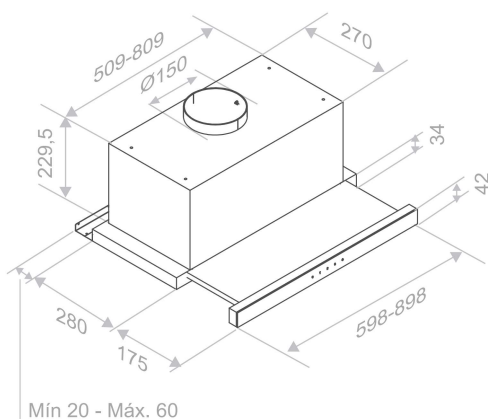

Acceso / Acces WEB



Touch NEGRO / Black Model. 60 cm

# IES Touch S.E.C. System

Inox  
Frontal cristal negro o blanco  
Stainless Steel  
Front black o white glass



Touch Blanco / White Model. 60 cm

## Modelos / Models

### S.E.C. System®

#### Motor Interior / Interior Motor

Front. (cm)	Motor	Ø tubo	Clas. Ener.	Ref.	P.V.R
<b>Cristal negro - Black Glass model</b>					
60	V.850	Ø150	A	008566	660 €
90	V.850	Ø150	A	008567	735 €
<b>Cristal blanco - White Glass model</b>					
60	V.850	Ø150	A	009082	695 €
90	V.850	Ø150	A	009083	775 €

## Opcionales / Options

Kits de recirculación. Ver página 210  
Activated carbon filters kit. See page 210

Cambio a LED cálido de 3000K. Suministrado con la campana.  
LED change to warm light LED 3000K. Available only at the factory. 80 €

## Notas / Notes

### AirClean

Sistema automático de funcionamiento del motor 10 min. cada hora durante 5 horas.  
Automatic working motor system for 10 minutes every hour during 5 hours.

## Esquemas medidas / Technical Drawings

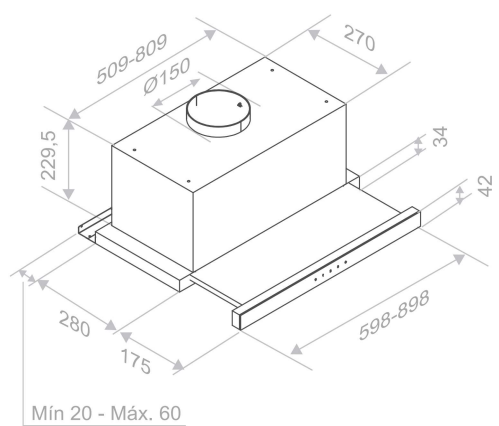

Acceso / Acces WEB

Integración / Integrated

# GR20



Modelos / Models

## Motor Interior / Interior Motor

Front. (cm)	Motor	Ø tubo	Clas. Ener.	Ref.	P.V.R
60	V.700	Ø120	D	010046	220 €
	V.700 ECS	Ø120	D	010047	250 €

Opcionales / Options

Kits de recirculación. Ver página 210  
Activated carbon filters kit. See page 210

Esquemas medidas / Technical Drawings

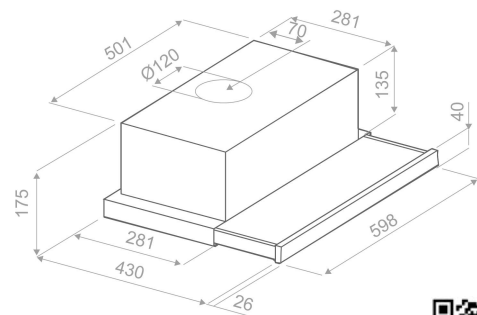

Acceso / Acces WEB

# GR05



Modelos / Models

## Motor Interior / Interior Motor

Front. (cm)	Motor	Ø tubo	Clas. Ener.	Ref.	P.V.R
60	V.700	Ø150	D	009672	245 €
	V.730	Ø120	A	010024	295 €
90	V.700	Ø150	D	009673	265 €
	V.730	Ø120	A	010025	295 €

Opcionales / Options

Kits de recirculación. Ver página 210  
Activated carbon filters kit. See page 210

Esquemas medidas / Technical Drawings

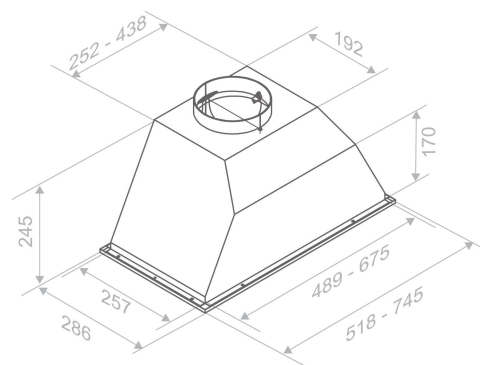

Medidas encastre  
Built in Sizes

60	493 x 260
90	679 x 260



Acceso / Acces WEB

# INFORMACIÓN TÉCNICA

## TECHNICAL INFORMATION

CAMPANAS DECORATIVAS  
DECORATIVE COOKER HOODS



# Especificaciones técnicas de motores

## Technical Specifications Motors

VERSIÓN MOTORES MOTOR VERSIONS	TIPO MOTOR MOTOR TYPE	Ø conducto duct	CAUDAL / AIRFLOW			POTENCIA SONORA SOUND POWER		POTENCIA MÁXIMA MAXIMUM POWER	PRESIÓN MÁXIMA MAXIMUM PRESSURE	Conducto máximo recomendado Max recom. ducting	Longitud de serie en cables conexión motor exterior
			Q MÍN.* m³/h	Q MAX.* (Intensive) m³/h	Q MAX. (Free 0Pa) m³/h	Lw MIN.* dBA	Lw MAX.* dBA	W MAX. W	Pa	Metros lineales linear meters	
<b>INTERIORES (dentro de la campana) / INTERIOR (inside the hood)</b>											
V.700	INT	120 / 150	199	382	560	49	60	140	260	4	-
V.730	INT	120	195	456	466	42	60	125	296	5	-
V.750	INT	125	218	483	590	45	66	150	455	6	-
V.850	INT	150	307	690	738	48	60	265	604	8	-
V.950	INT	150	158	757	763	38	61	350	589	6	-
V.1350	INT/EXT *h	150	313	856	910	46	61	290	505	10	-
<b>INTERIORES ECO (dentro de la campana) / INTERIOR ECO (inside the hood)</b>											
V1130 ECO	INT	150	141	592	1015	38	59	85	530	8	-
V1050 ECO SEC PLUS	INT	150	134	760	905	36	50	170	440	8	-
V1250 ECO	INT	150	250	941	1080	38	58	230	490	10	-
V1350 ECO	INT/EXT *h	150	250	970	1085	39	61	230	490	10	-
V2200 ECO	INT	200	642	1604	2190	47	61	750	1030	15	-
<b>INTERMEDIOS EXTERIORES / IN-LINE REMOTE MOTORS</b>											
V1200 TIPO 1	EXT	150	199	602	763	38	54	350	589	6 *a	7
V2000 TIPO 1	EXT	200	293	807	1495	32	41	250	720	10 *b	7
<b>INTERMEDIOS EXTERIORES ECO / ECO IN-LINE REMOTE MOTORS</b>											
V1550 ECO TIPO 1 Y 2	EXT	150	198	767	1080	36	51	230	490	10 *c	6
V2450 ECO TIPO 2 Y 3	EXT	200	430	1440	2335	39	59	168	498	12 *d	6
V2600 ECO TIPO 1 Y 2	EXT	200	642	1795	2190	45	59	750	1030	15 *e	12
V3000 ECO TIPO 2 Y 3	EXT	200	645	2915	3450	44	61	660	960	18 *e	12
<b>MURO ECO (Fachada) / ECO OUTDOORS WALL MOTOR</b>											
V1300 ECO	MUR	150	217	812	1290	42	56	168	990	6	6
<b>TEJADO ECO (En tejado o chimenea exterior) / ECO OVER-THE-ROOF MOTORS</b>											
V2350 ECO	TEJ	200	410	1675	2335	44	55	168	498	12 *f	12
V3300 ECO	TEJ	200	612	2880	3450	53	68	660	920	18 *g	18

\*a. De campana a motor máx. 2m

\*b. De campana a motor mín. 2m - máx. 6m

\*c. De campana a motor máx. 4m

\*d. De campana a motor mín. 4m - máx. 6m

\*e. De campana a motor mín. 6m - máx. 12m

\*f. De campana a motor mín. 4m - máx. 12m

\*g. De campana a motor mín. 6m - máx. 18m

\*h. Motor exterior disponible según modelo, consultar catálogo.

\*a. From hood to motor max. 2m

\*b. From hood to motor mín. 2m - máx. 6m

\*c. From hood to motor máx. 4m

\*d. From hood to motor mín. 4m - máx. 6m

\*e. From hood to motor mín. 6m - máx. 12m

\*f. From hood to motor mín. 4m - máx. 12m

\*g. From hood to motor mín. 6m - máx. 18m

\*h. Outdoor motor available depending on model, see catalogue.

Limite el número de curvas en la canalización, ya que cada curva reduce la eficacia de la aspiración:

- En Ø150 mm un codo 90° = 1m lineal.
- En Ø200 mm un codo 90° = 2,5m lineal.

Ejemplo: Si se usan 2 codos de 90°, la longitud total de una canalización de 3m lineales Ø150mm (3+1+1), es de 5m.

Si se usan 2 codos de 90°, la longitud total de una canalización de 3m lineales Ø200mm (3+2,5+2,5), es de 8m.

Los valores indicados están realizados a partir de ensayos en condiciones de laboratorio. Dependiendo del modelo y características de cada campana podrían variar sensiblemente. Debido a las constantes mejoras que Pando realiza en sus productos, esta información está siempre actualizada en nuestra web ([www.pando.es](http://www.pando.es))

\* UNE-EN 61591, UNE-EN 60704-2-13

(\*) El uso de la certificación y de la marca es exclusivo para los modelos marcados con este símbolo en su etiqueta identificativa.

(\*) The use of the certification and the brand is exclusive for all models marked with this symbol in its identifying label.

Limit the number of bends along the ducting, since every bend reduces the effectiveness of the airflow capacity:

- In Ø150 mm a 90° curve = 1 m linear.
- In Ø200 mm a 90° curve = 2.5 m linear.

i.e. If you use 2 curves of 90°, the total effective length of a 3 m linear 150 Ø duct is 3+1+1=5 m.

If you use 2 curves of 90°, the total effective length of a 3 m linear 200 Ø duct is 3+2.5+2.5=8 m.

Given values are based on tests under laboratory conditions. They may slightly vary depending on the model and the features of each hood. Due to the constant improvements that made by Pando in their products, this information is always up to date on our website ([www.pando.es](http://www.pando.es))



(\*) Certificación de Producto SGS conforme a la norma UNE-EN 60335

# Instalación de campanas

## Hood installation guidelines

Hay que recordar siempre que las campanas extractoras de humos son aparatos electrodomésticos que necesitan de una instalación previa de tubo conductor de humos y que posteriormente deben respetarse unas condiciones mínimas de colocación (altura y anchura de campana sobre la encimera de cocción), y por supuesto, las de seguridad. El no respetar estas condiciones, supondrá con toda seguridad, que la campana tenga un rendimiento deficiente y muchas veces nulo. A continuación les describimos las condiciones mínimas de colocación de una campana:

Please remember that a cooker hood is a domestic appliance used for extracting all odours, smoke and grease particles produced while cooking in the kitchen. Possibly this hood will be connected to an existing trunking to outside. Also the minimum distances from the cooker top (height and width) must be maintained to achieve the proper safe and optimized hood performance. Failure to take these parameters into account will create a deficient, or even void, effectiveness of extraction. Before choosing your cooker hood you should evaluate your kitchen dimensions as well as the appliances involved. Care should also be taken as to the correct connections to any reused existing ducts, as explained later.

**La dimensión de la campana debe de ser igual o más grande que la placa de cocción para un funcionamiento óptimo.**

**Hood size must be equal or larger than the hob for a proper working**



Bien instalada  
Correct



Mal instalada  
Wrong

**Imprescindible que la campana está centrada sobre la zona de cocción**  
**It is important that the cooker hood is installed centered above the hob**

**Distancia óptima entre la campana y la placa de cocción**  
**Optimum distance between cooker hood and cooktop**

**Campanas de pared**  
**Wall cooker hoods**



**Altura óptima**  
Optimum height  
650 mm

**Campanas de isla**  
**Island cooker hoods**



**Altura óptima**  
Optimum height  
650 mm

**Campanas de integración**  
**Integration cooker hoods**



**Altura óptima**  
Optimum height  
Induction: 550 mm  
Gas: 650 mm

**Campanas de techo**  
**Ceiling cooker hoods**



**Altura óptima**  
Optimum height  
1400 - 1700 mm

# CUATRO TIPOS DE MOTORES FOUR TYPES OF MOTORS

Las mejores prestaciones, mínimo consumo eléctrico y excelente nivel sonoro.  
Maximum performance, minimum power consumption and excellent noise level.

A

## Motores interiores Internal motors

V.700, V.730, V.750, V.850, V.950, V.1350  
V.1130 ECO PLUS,  
V.1050 ECO SEC System PLUS,  
V.1250 ECO SEC y/and V.2200 ECO SEC



Motores instalados dentro del cuerpo de la campana.  
Muchas de las versiones incorporan sistemas ECO eficientes y de gran rendimiento y bajo nivel sonoro.  
El sistema V.1050 proporciona una reducción sonora de hasta un 20%.  
V.1130 ECO PLUS consigue hasta un 57% más de caudal y mejora de presión en conducto.

Motors fitted inside the hood casing.  
Many of the versions feature ECO efficient systems offering high performance at very low noise levels.  
The V.1050 system offers up to 20% noise reduction  
The V.1130 ECO PLUS achieves up to 57% higher flow and improved pressure in the pipe

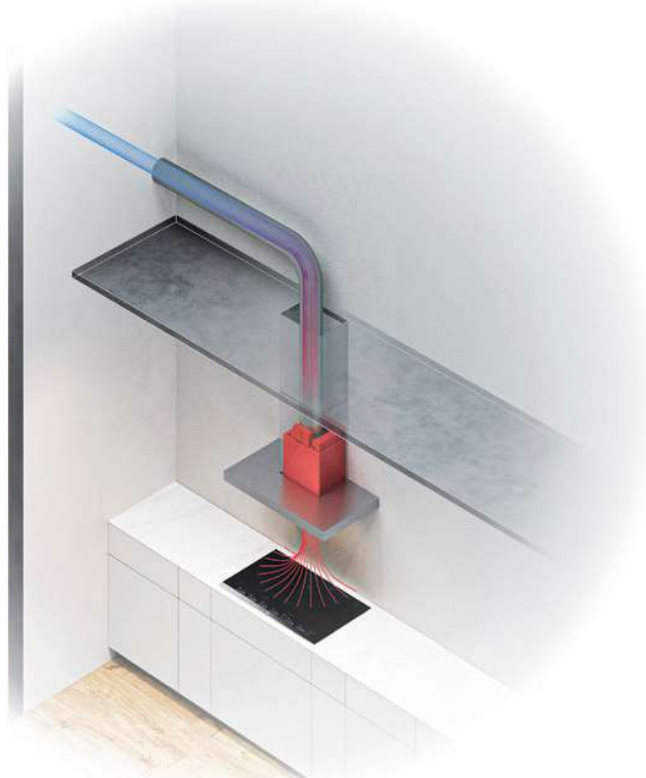

B

## Motores intermedios exteriores Duct-in-line remote motors

V.1550 ECO, V.2450 ECO  
V.2600 ECO y/and V.3000 ECO T2  
V.1200 y/and V.2000S



Motores intermedios de colocación fuera del chasis de la campana. Pueden instalarse en falso techo o bajo cubierta. No pueden instalarse a la intemperie.  
Gran capacidad de extracción sin ruido.

INCLUIDO

Las unidades con motorizaciones V.2450 y V.3000 Intermedio Exterior incorporan de serie 5 m de tubo de extracción de humos SEC System® de Ø203 mm interior y Ø253 mm exterior.

Duct-in-line remote motors fitted separately from the hood chassis.  
They can be mounted on a false ceiling or under the roof. They cannot be installed outdoors. High extraction capacity and without noise.

INCLUDED

The models with the V.2450 and V.3000 duct-in-line remote motor comes with 5 m of S.E.C. fume extractor flue as standard System®, interior Ø 203 mm and exterior Ø 253.

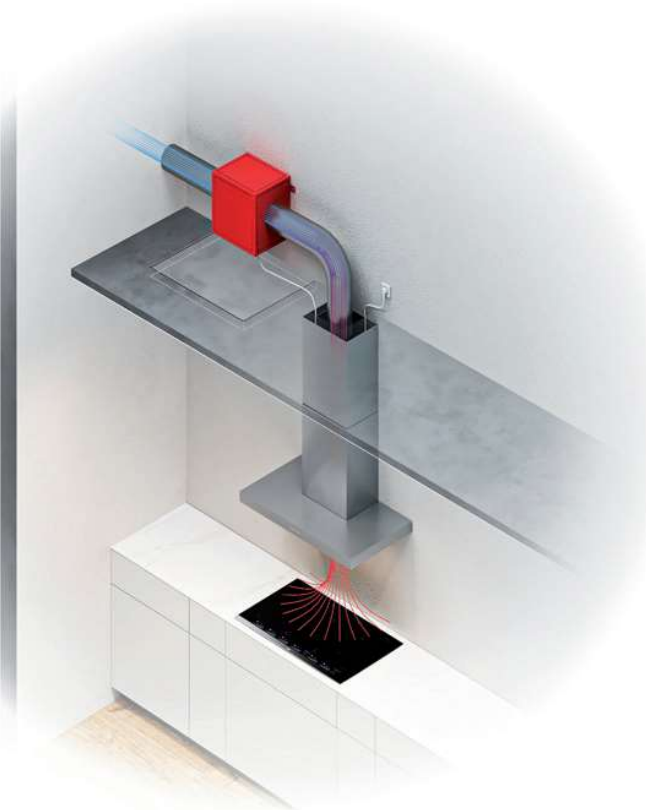

C

## Motores tejado Roof outdoor motors

V.2350 ECO  
y/and V.3300 ECO



Motores para su colocación en tejado. Totalmente preparados para cualquier inclemencia del tiempo. Gran capacidad de extracción sin ruido. **INCLUIDO**

Las unidades con motorizaciones V.2350 y V.3300 Tejado, incorporan de serie 5 m de tubo de extracción de humos SEC System® de Ø203 mm interior y Ø253 mm exterior.

Motors for mounting on the roof top of the house. Suitable for all weathers. High extraction capacity with no noise.

High extraction capacity with no noise.

**INCLUDED**

The models with the V.2350 and V.3300 Roof motor system, comes with 5 m of S.E.C. fume extractor flue as standard System®, interior Ø 203 mm and exterior Ø 253.

D

## Motor exterior de muro Wall outdoor motor

V.1300 ECO



Motores para su colocación adosados al muro exterior de la casa. Totalmente preparados para cualquier inclemencia del tiempo. Gran capacidad de extracción sin ruido,

Motors for mounting on the outside wall of the house. Suitable for all weathers. High extraction capacity with no noise.

High extraction capacity with no noise.

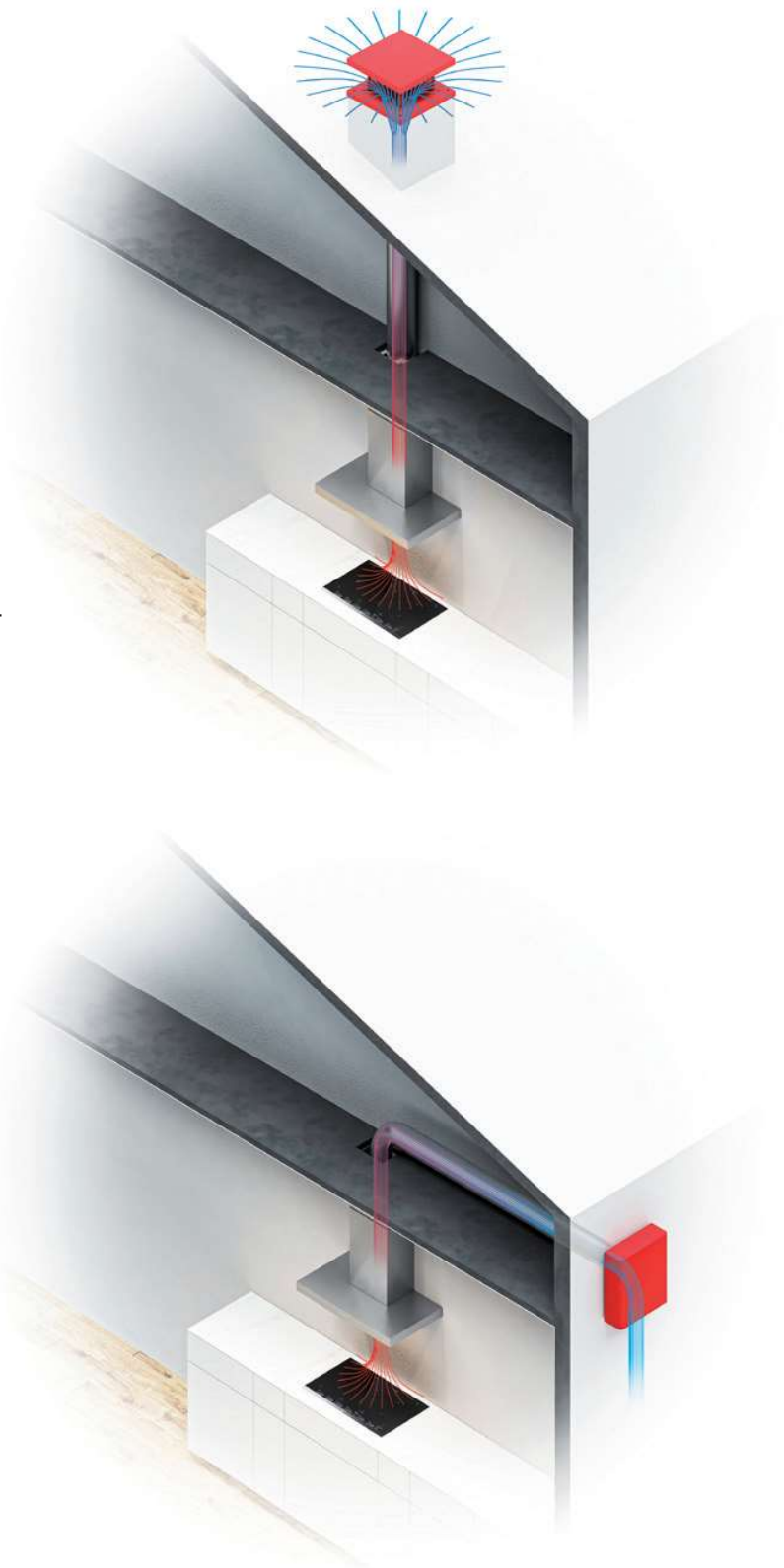



## B Motores intermedios exteriores para falso techo

### Duct-in-line remote motors (false ceiling)

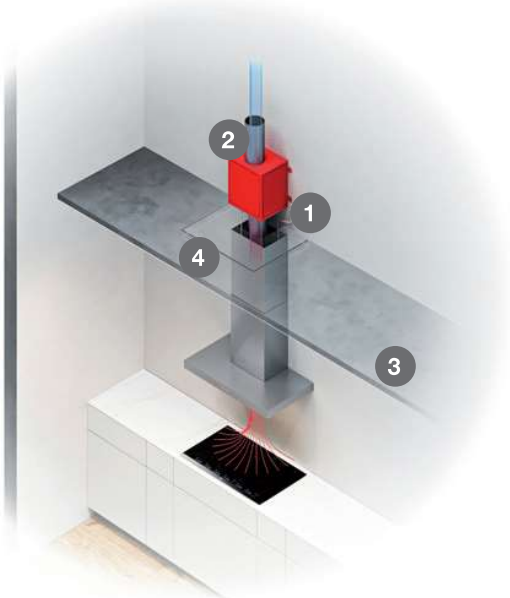

1 Motor  
Motor

2 Salida de humos  
Duct run

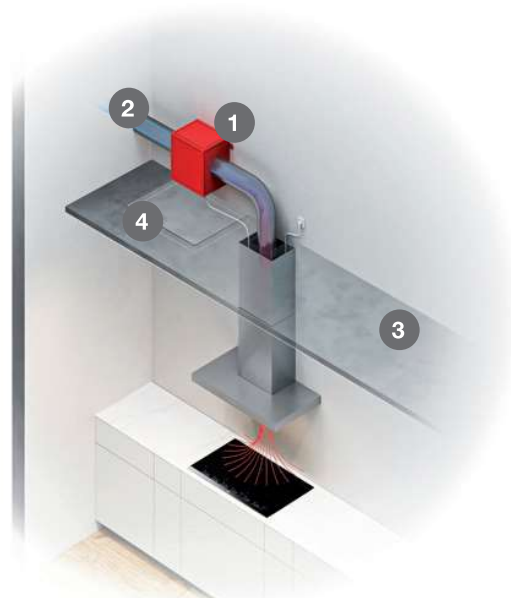

3 Falso techo  
False ceiling

4 Registro acceso al motor  
Motor access panel

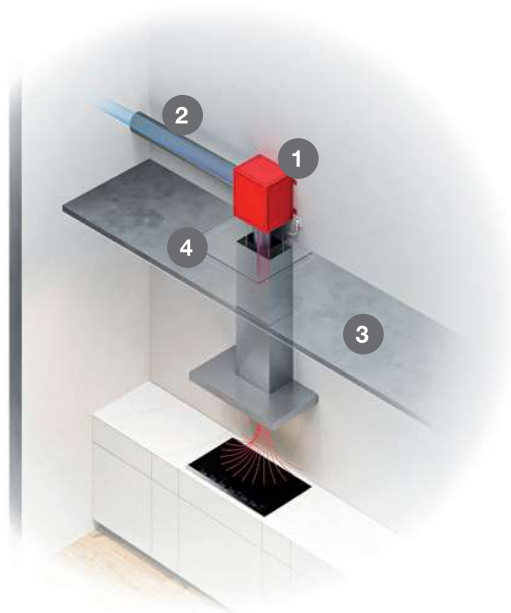

NOTA: Se debe dejar un tubo pasa cables de diámetro 4 cm ya que no se puede cortar el conector del cable.

NOTE: It's necessary to keep a the lead-through of 4 cm diameter, because the connector of the cable cannot be cut.

**B**

# Esquemas motores intermedios exteriores

## Duct-in-line remote motor diagrams

**Motorizaciones ECO:**

Algunos de nuestros modelos incorporan de serie motor ECO. Si el modelo seleccionado por Usted no dispone de serie de esta opción, no dude en consultarnos y le informaremos si es posible instalar un motor ECO en su campana.

**ECO motors:**

Some of our models come standard with ECO motor. If the motor you selected does not have this option as standard, please do not hesitate to contact us. We will inform you if it is possible to install an ECO motor in your hood.

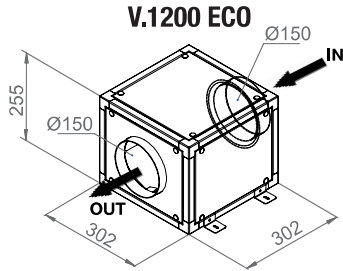

**V.1550 N ECO Tipo/ Type 1**

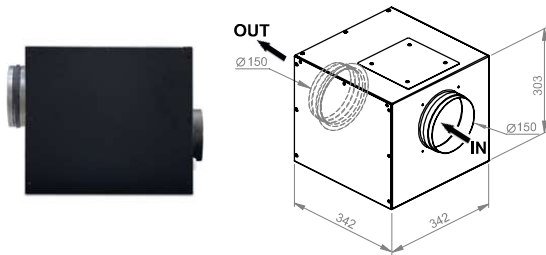

**V.2450 ECO Tipo / Type 2**

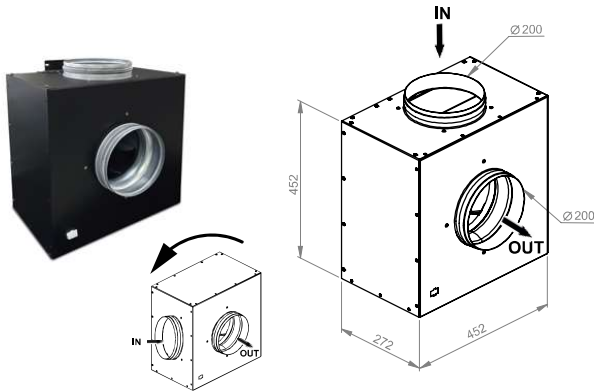

**V.2600 ECO Tipo / Type 1**

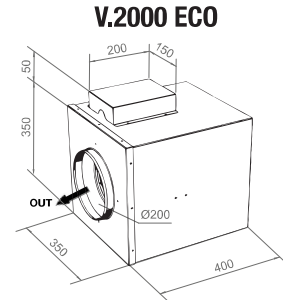
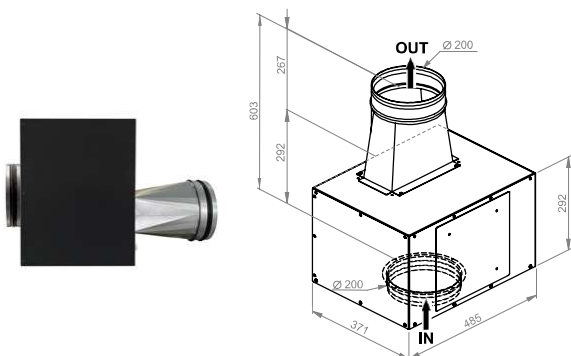

**V.1550 N ECO Tipo/ Type 2**

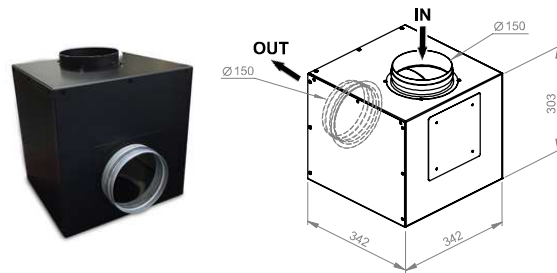

**V.3000 N ECO Tipo / Type 2**

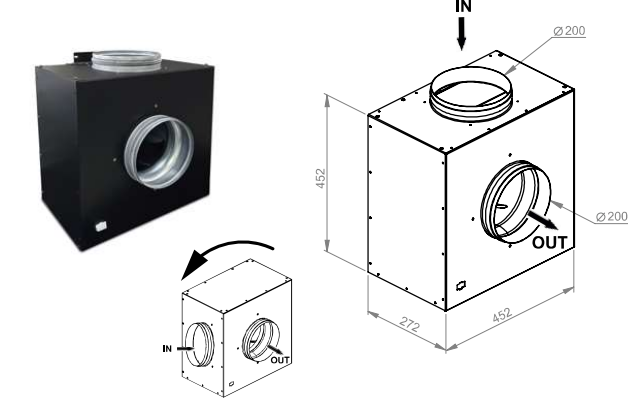

**V.2600 ECO Tipo / Type 2**

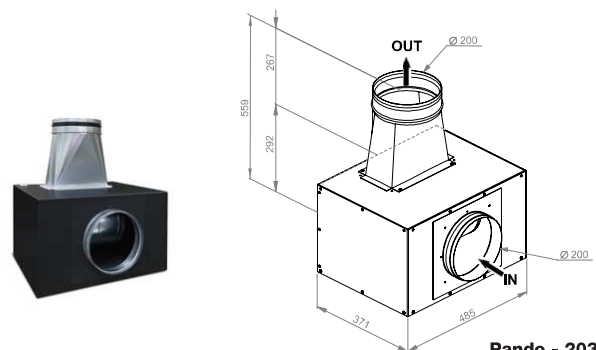

C

## Motores exteriores de tejado ECO ROOF outdoor motors (roof or chimney)

Su excelente facilidad de colocación y montaje, su menor envergadura (que mejora mucho su presentación estética), sumada a su alta capacidad de trabajo, hacen que sean las mejores elecciones de motorización para aquellos proyectos en los que puedan proponerse como alternativa a los motores tradicionales.

The easy mounting and installation process with its more compact dimensions (improving the aesthetics) together with its high performance, make the roof outdoor motors an excellent option for those projects where an alternative to traditional indoor motors is possible.

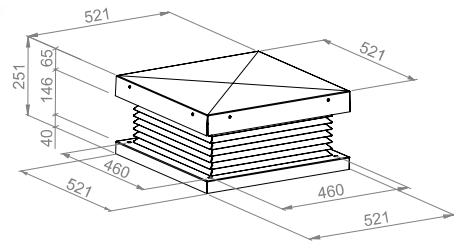
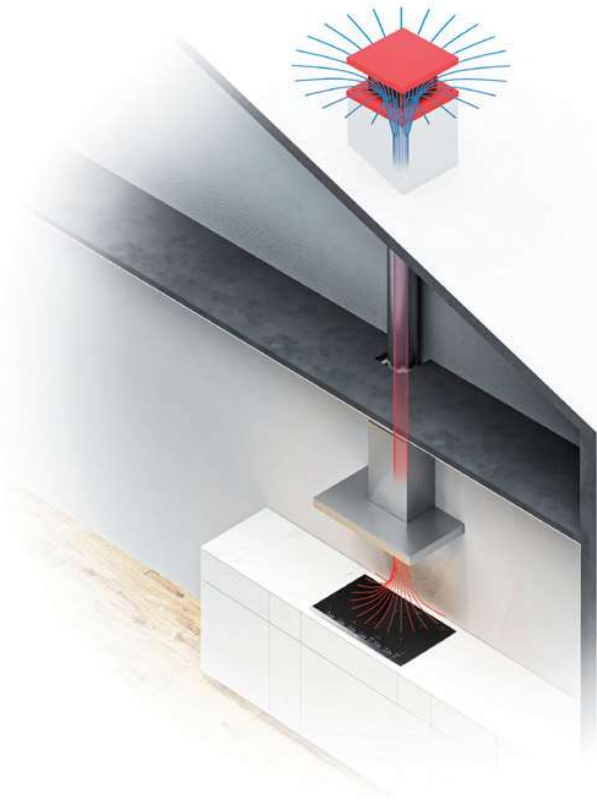

**Motor exterior de tejado V.2350 ECO**  
ROOF Remote Motor V.2350 ECO



**Motor exterior de tejado V.2350 ECO  
y V.3300 ECO ESPECIAL**  
ROOF Remote Motor v.2350 ECO  
and V.3300 ECO SPECIAL

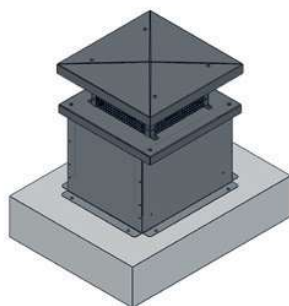

**Montaje sobre la caja de soporte  
insonorizada.**  
Installation over Sound proof  
Support Box.

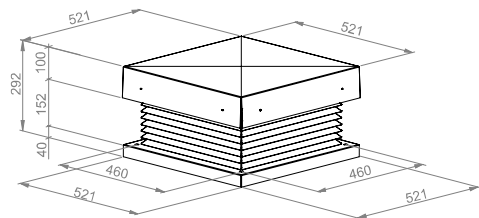

**Motor exterior de tejado V.3300 ECO**  
ROOF Remote Motor V.3300 ECO

**NOTA:** Se debe dejar un tubo pasa cables de diámetro 4 cm ya que no se puede cortar el conector del cable.

**MUY IMPORTANTE:** la ubicación y acceso al motor, debe de ser "seguro" para los Sres. del Servicio de Asistencia Técnica, a fin de que puedan realizar trabajos de mantenimiento o posibles reparaciones. Si la ubicación del motor presenta riesgos para las personas, Pando se reserva el derecho de no actuación, hasta que las condiciones sean las adecuadas para la seguridad del S.A.T.

**Note:** It's necessary to keep a lead-through of 4 cm diameter, because the connector of the cable cannot be cut.

**VERY IMPORTANT:** The position of and the access to the motor must be safe to operate of After-Sales technical and maintenance workers. Should the motor position provide any risk to personnel, Pando reserves the right to refuse servicing the product until such safe conditions exist again.

**D**

## Motor exterior de Muro Outdoor WALL Motor

Motor de instalación a muro que facilita la instalación del motor en el exterior en casi cualquier tipo de vivienda.  
Su gran facilidad de colocación y sus distintas posibilidades de montaje hacen de este tipo de instalación una muy buena alternativa.

The wall-mounted motor facilitates the installation of the motor outdoors in almost any type of home.  
Its great ease of installation and the various mounting possibilities make this type of installation an excellent alternative.

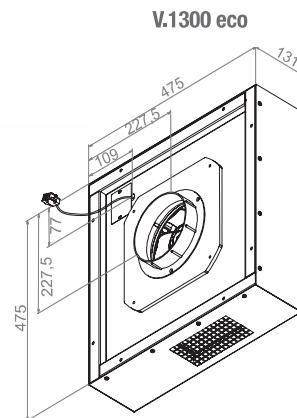
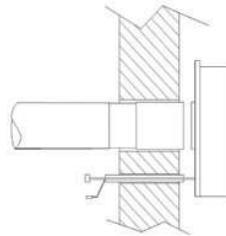
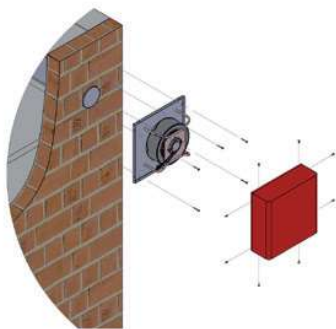
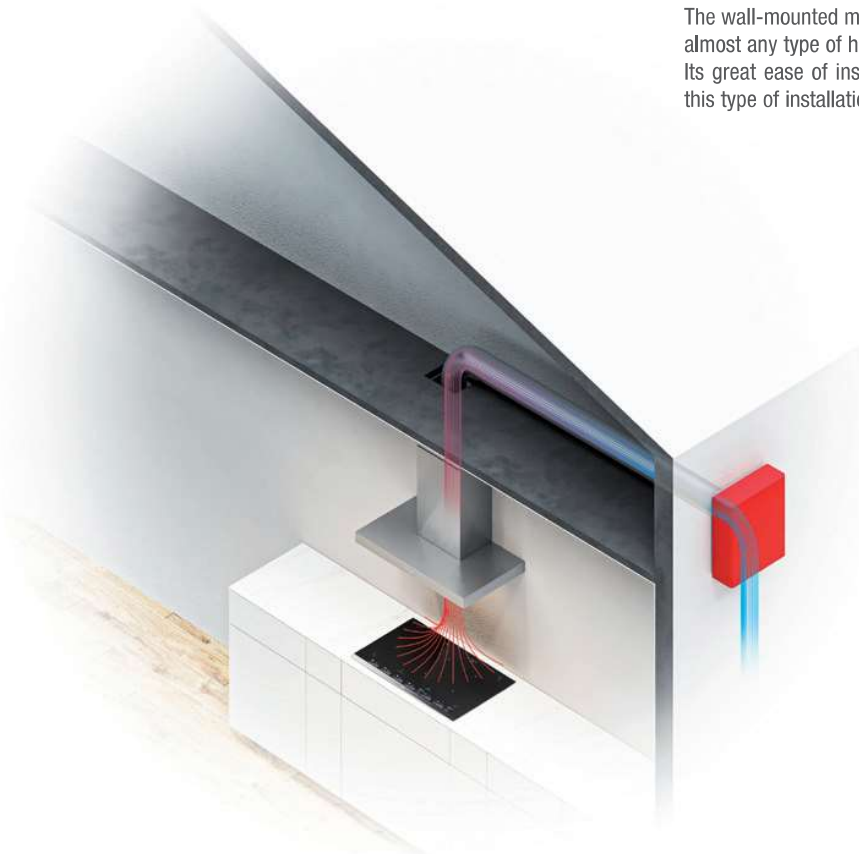

**NOTA:** Se debe dejar un tubo pasa cables de diámetro 4 cm ya que no se puede cortar el conector del cable.

**MUY IMPORTANTE:** La ubicación y acceso al motor, debe de ser "seguro" para los Sres. del Servicio de Asistencia Técnica, a fin de que puedan realizar trabajos de mantenimiento o posibles reparaciones. Si la ubicación del motor presenta riesgos para las personas, Pando se reserva el derecho de no actuación, hasta que las condiciones sean las adecuadas para la seguridad del S.A.T.

**Note:** It's necessary to keep a lead-through of 4 cm diameter, because the connector of the cable cannot be cut.

**VERY IMPORTANT:** The position of and the access to the motor must be safe to operate of After-Sales technical and maintenance workers. Should the motor position provide any risk to personnel, Pando reserves the right to refuse servicing the product until such safe conditions exist again.



# Sistemas de fijación de filtros de carbón activado

## Recirculation kit installation in ductless system



QR SISTEMAS FIJACIÓN  
QR KIT INSTALLATION

La recirculación o reciclaje del aire extraído por una campana extractora de humos, se realiza a través de unos filtros especiales de carbón activado. Su función es la de purificar el humo extraído y enviarlo nuevamente al recinto. Esta modalidad, sólo debe utilizarse en los casos en que no sea posible efectuar una instalación de tubo conductor de humos que lleve los gases al exterior de la cocina, o bien, cuando al lugar donde van a parar estos, pueda molestar el olor o el humo extraído. Esta última utilidad también se propone con fines ecológicos, para evitar lanzar a la atmósfera gases contaminantes.

Ductless option is designed to be used only in situations where running a duct isn't possible. In a ductless scenario, you will have to use a carbon filter. This filter will clean the air from odors, releasing the purified and clean air back into your kitchen through the vent holes located at the top of the extension flue.

The recirculation system should only be used when an evacuation of the odors to the exterior is impossible. The use of charcoal filters avoids the pollution with polluting gases from cooking.

### OPCIÓN A / OPTION A

#### FILTROS FCA REDONDOS:

Se colocan en horizontal o vertical, enroscados en los laterales del motor, mediante un cuarto de vuelta en el sentido de las agujas del reloj.

#### ROUND FCA FILTERS.

These are fitted horizontally or vertically, screwed to the sides of the motor by a quarter turn clockwise.

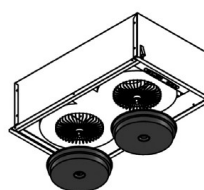

Volutas de motor en posición horizontal  
Motor volutes in horizontal position

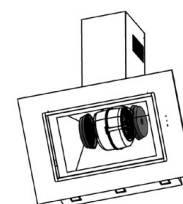

Volutas de motor en posición vertical  
Motor volutes in vertical position

### OPCIÓN B / OPTION B

#### FILTROS FCA/FCLR AE PLANOS:

Se sitúa en la pestaña interior, donde van colocados los filtros metálicos, detrás de estos o previa colocación de la bandeja de soporte de filtros FCA/FCLR AE, encajados en esta.

#### FLAT FCA / FCLR AE FILTERS.

Fitted on inside tab, where the metal filters are mounted, behind them or before fitting the FCA/ FCLR AE filter support tray.

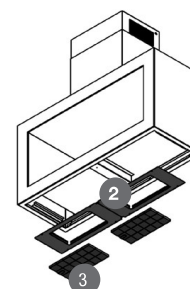
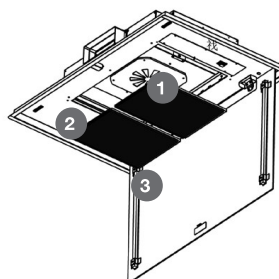

### OPCIÓN C / OPTION C

#### FILTROS INOXIDABLES CON CARTUJO:

Se colocan los FCLR AE encajados en la cara posterior e interior del filtro metálico, llevan pestañas y anclajes de cierre.

#### STAINLESS STEEL FILTERS WITH CARTRIDGE.

The FCLR AE are fitted at the back or inside the metal filter. They have tabs and fixing points.

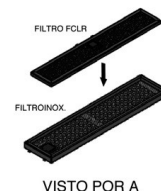
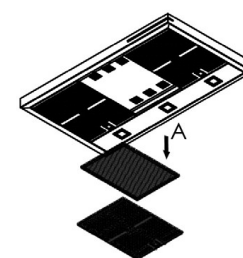
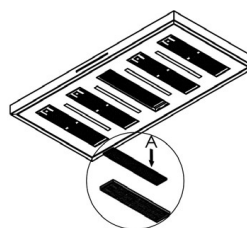

VISTO POR A

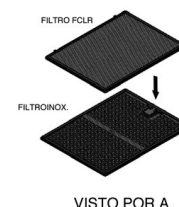

VISTO POR A

### OPCIÓN D / OPTION D

#### DIFUSOR:

Se colocan las cápsulas cerámicas FCCR AE que van sujetas en una jaula de acero, dentro del cuerpo del difusor.

#### DIFFUSER.

FCCR AE ceramic capsules are fitted, secured in a steel cage inside the body of the diffuser.

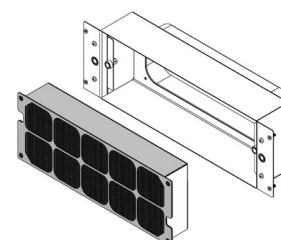
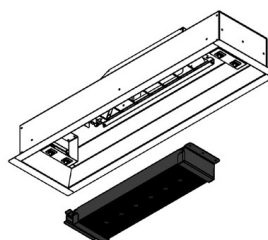

# Reducción del diámetro de tubo conductor de humos

## Ducting elbows, adaptors and reducers

Conviene tener en cuenta las siguientes indicaciones cuando por causas del recorrido del tubo conductor de humos, debe de realizarse una reducción del conducto. En primer lugar debe quedar bien claro que realizar reducciones de diámetro de tubo, SIEMPRE IMPLICA TENER PERDIDAS DE ASPIRACIÓN. Por tanto, cuando debamos realizarlas "FORZOSAMENTE", debemos tener en cuenta las siguientes premisas:

It is important to note the following methods of how ductwork reduction is achieved. A reduction in ductwork diameter ALWAYS results in a loss of airflow.

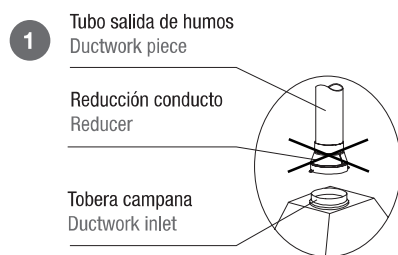

1. No efectuar nunca una reducción de diámetro de tubo inmediatamente a la salida de la tobera de la campana

1. Do not install a ductwork reduction immediately after the motor outlet.

2. Realizar siempre la reducción de diámetro de tubo de forma paulatina

2. Always reduce the diameter in stages

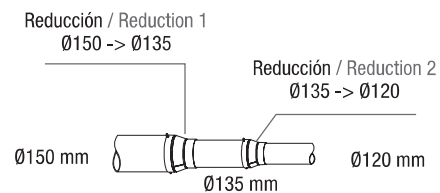

3. No realizar nunca las reducciones donde existan curvas o codos, dentro de la instalación. DEBEN DE REALIZARSE SIEMPRE EN TRAMOS RECTOS Y A LA MAYOR DISTANCIA POSIBLE DE LA CAMPANA

3. Do not include a reduction involving a bend or elbow. PANDO RECOMMENDS TO REALIZE THE REDUCTIONS ALWAYS IN STRAIGHT SECTIONS AND AS FAR AWAY FORM THE HOOD AS POSSIBLE.

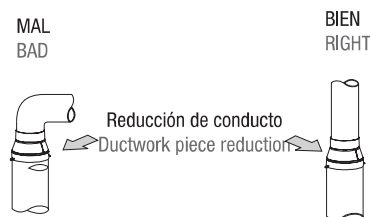

4. Evitar en lo posible que la instalación contenga demasiadas curvas o codos. Si existieran, intentar que los mismos tengan el mínimo número de grados de giro posible.

4. If a bend in the ductwork is unavoidable, then use the least bend possible.

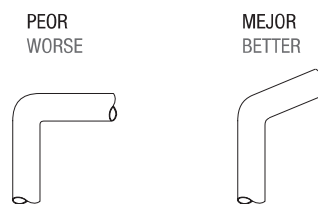

### Consecuencias que puede presentar las instalaciones con reducciones del diámetro de tubo:

- Reducción de la aspiración
- Aumento de la condensación
- Aumento del sonido del motor
- Incremento de acumulación de líquidos en el interior del tubo de salida de humos

### Consequences from reduced ductwork sizes.

- Reduction of power of aspiration.
- Increased condensation.
- Increased noise.
- Forming of liquids inside the ducting parts.

# Limpieza y mantenimiento

## Maintenance and Care

### Campanas DEKTON® / DEKTON® cooker hoods

Debido a su porosidad prácticamente nula, la superficie ultra compacta Dekton® es altamente resistente, tanto a las manchas ocasionadas en el uso cotidiano como a productos químicos, siendo ideal para su uso en la cocina.

Para la limpieza habitual se recomienda el uso de un limpiador de encimeras de piedra especializado, consultar web, junto con una esponja o estropajo de fibras suaves. En caso de no disponer de este producto, la mejor opción es el uso de agua y jabón neutro.

- Evitar radiaciones directas de muy alta temperatura como chimeneas, barbacoas, etc.
- Evitar el contacto directo con llama.
- No pulir la superficie. Evitar utilizar estropajos metálicos o con partículas abrasivas.

Consulte la página web [www.dekton.com](http://www.dekton.com) para más detalles y métodos de limpieza, mantenimiento en general y exposición a sustancias químicas.

Due to its practically zero porosity, the ultra-compact Dekton® surface is highly resistant, both to stains resulting from everyday use and to chemicals, making it ideal for use in the kitchen.

For regular cleaning it is recommended to use a specialised stone worktop cleaner (consult website) with a soft fibre cloth or sponge. If this product is not available, the best option is to use water and neutral soap.

- Avoid direct radiation at very high temperatures such as fireplaces, barbecues, etc.
- Avoid direct contact with flame.
- Do not polish the surface. Avoid using metal scouring pads or those containing abrasive particles.

Consult the [www.dekton.com](http://www.dekton.com) website for further details and methods of cleaning, general maintenance and exposure to chemical substances

### Campanas esmaltadas / Enamelled cooker hoods

El esmaltado de las campanas, esta realizado con sistema epoxi y cocción a 200°. Su dureza es excepcional, lo mismo que su durabilidad. No obstante, dependiendo de los productos que utilizemos para su limpieza y mantenimiento, podemos mermar considerablemente sus cualidades.

La mejor opción para realizar una limpieza óptima del EXTERIOR de la campana, es realizarlo a través de una solución jabonosa estandar anti-grasa neutra y aclararlo posteriormente con un paño húmedo. NO UTILIZAR ESTROPAJOS que pueden llegar a rayar el esmalte, realizarlo con paños suaves o esponjas. Evitar empapar la campana con agua en el enjuague, para que ésta no quede estancada en las juntas. Esto podría ocasionar, con el paso del tiempo, principios de oxidación.

Para realizar la limpieza INTERNA de la campana, SE DEBE DESCONECTAR EL APARATO DE LA RED ELECTRICA y no introducir NUNCA paños mojados en exceso. Tener los filtros metálicos perfectamente limpios, evitará de forma efectiva, que la zona interna de la campana se ensucie. El lavado aconsejado es igual al que realicemos en el EXTERIOR del aparato.

En caso de optar por otros productos de limpieza, aconsejamos siempre que estos no sean abrasivos a los esmaltes y QUE ESTEN EXENTOS DE SILICONAS, ÁCIDOS, LEJÍAS, AMONÍACOS, SOSAS, AGENTES CORROSIVOS Y DERIVADOS.

Enamelling is achieved by epoxy painting and then heating at 200° C. It provides a very hard but brittle surface which has a long life. However care is needed as to cleaning, otherwise damage can occur which will shorten its life dramatically.

For best practice use a soft cloth and soap and water (sparingly) and dry off thoroughly with a further soft cloth. Do not use scouring pads as they will damage the surface allowing water penetration and eventually causing rust spots.

For internal cleaning please SWITCH OFF the hood at the mains switch, unplug, and only use a damp (not wet) cloth. Keeping the metallic grease filters clean will also help the inner parts from getting dirty. Make sure hood is completely dry before replacing plug and switching on.

In the event that other cleaning products are chosen, we always advise that these should not be abrasive on enamel and THEY MUST BE FREE FROM SILICON, ACID, BLEACH, AMMONIAC, SODA, CORROSIVE AGENTS AND DERIVATIVES.

# Limpeza y mantenimiento

## Maintenance and Care

### Campanas inoxidables / Stainless Steel cooker hoods

Para la limpieza y conservación del acero, actuaremos de la misma forma que lo hacemos en las campanas esmaltadas, aplicando en un paño una solución jabonosa neutra y aclarando después con un paño húmedo. Una vez seca la campana, bastará aplicar el Limpiador de Acero Inox. Pando para igualar los distintos brillos o sombras que hayan podido quedar después de la limpieza, dando de esta forma un acabado homogéneo y perfecto.

ES EXPRESAMENTE PERJUDICIAL para el acero Inox, la utilización para su limpieza de ÁCIDOS, SOSAS, AMONIACOS, CLORUROS o DERIVADOS. Todos ellos pueden destruir las características químicas de los aceros, provocando oxidaciones parciales o totales, puntos negros, sombras de distinto brillo, etc.... Con los ácidos (agua fuerte, sulfumán, lejías, etc), debe de tenerse una especial precaución, puesto que en algunos casos no es necesario que se aplique el producto directamente al acero, basta que el "humo o vapor" que desprende el ácido, puede adherirse a la chapa y provocar los daños descritos anteriormente.

#### MUY IMPORTANTE:

Debe de tenerse en cuenta en las limpiezas industriales de obra nueva o reforma, que el habitáculo de la cocina debe de quedarse perfectamente ventilado después de su limpieza, para evitar que en el ambiente quede el "humo o vapor" antes descrito. No realizarlo, provocará daños irreversibles en el acero inoxidable. Los responsables de la limpieza igualmente deberán de tener muy en cuenta el "no utilizar productos de limpieza" , como los anteriormente expuestos, que perjudican directamente al acero inoxidable.

Stainless Steel surfaces should be cleaned regularly to make sure that your hood will continue to look good. It is a good rule to use a soft damp cloth that has been wetted in warm soapy water using a neutral detergent. Make sure you clean the hood in the direction of the stainless finish. Never use abrasive products. We also recommend using cleaning products specifically for cleaning stainless steel that are available through retail outlets.

Pando realise that getting the perfect result from cleaning stainless steel is not always easy, and so has created a specific Pando cleaning product, a special wipe which is impregnated with a blend of oils that thoroughly cleanses stainless steel and leaves it gleaming longer whilst providing an anti-fingerprint finish.

#### VERY IMPORTANT:

It is important to remember that when industrial cleaning in new or refurbished rooms that thorough ventilation should be maintained to ensure that there is no irreparable damage to the stainless steel finishes from dust or steam.

### Limpiador Inox Pando

#### Stainless Steel cleaner

Pedido mínimo: 1 Caja de 6 unidades. Portes debidos.

Los portes de este producto serán PAGADOS si se realiza un pedido mínimo de 2 cajas de 6 unidades o si el envío es conjunto con una campana.

Minimum order quantity: 1 box with 6 units. Pay collect on delivery. Transport charges are included if a minimum of 2 box (12 units) are ordered or cleaner is shipped together with a cooker hood.

Ref.	P.V.R.
009993	29 € unit.



### Filtros de Aluminio e Inoxidables / Metallic grease filters

Los filtros metálicos que equipan las campanas, están realizados en perfil de aluminio y malla del mismo material de aleación ligera. Es importante tener en cuenta que estos filtros deben ser cambiados por otros de repuesto, una vez estén deteriorados, ya que sirven de forma efectiva como corta llamas, ante una esporádica inflamación (evidentemente los filtros deben de estar SIEMPRE perfectamente limpios y sin restos de partículas grasas). Estos filtros pueden ser lavados a mano, con una solución jabonosa anti-grasa standard, o bien en el lavavajillas. Se recomienda que el lavado a mano se efectúe SIN ESTROPAJO, puesto que puede deteriorar la malla de aleación ligera; lo mejor en este caso es realizar el lavado por inmersión y posterior aclarado.

#### MUY IMPORTANTE:

Si el lavado se efectúa en el LAVAVAJILLAS, deberán de tenerse en cuenta las instrucciones que cada fabricante tiene, en cuanto se refiere al apartado de lavado de "UTENSILIOS DE ALUMINIO". No obstante, SIEMPRE SERA NECESARIO, que el lavado se efectúe en un programa CORTO, DONDE NO SE UTILICE NI EL SECADO, NI EL ABRILLANTADO. En caso de efectuar por error un lavado completo con secado y abrillantado, los filtros pueden quedar ennegrecidos o manchados con diferentes tonos.

Metallic filters supplied with Pando hoods are made from aluminium mesh. Once damaged or spoilt they should be replaced as they not only remove grease particles but also act as a fire wall against sudden ignition. They should always be kept clean and grease free. Pando filters can be either washed by hand or in the dishwasher. If by hand the use of a cloth could damage the mesh, so it is best to agitate the mesh in warm soapy water, rinse and air dry.

#### VERY IMPORTANT:

Should the filter be cleaned in a dishwasher, study the dishwasher instructions carefully as to the care of aluminium utensils. ALWAYS use a short programme with no drying or shining process included, otherwise the filter could end up darkened and or stained.



# ACCESORIOS

## ACCESSORIES

CAMPANAS DECORATIVAS  
DECORATIVE COOKER HOODS

Kits de recirculación por modelo  
Recirculation kits by model



QR KITS RECIRCULACIÓN  
QR RECIRCULATION KITS

### Kits de recirculación por modelo / Recirculation kits by model Campanas de Pared / Wall cooker hoods

Modelo	Frontal (cm)	Color	Versión motor	Kit sistema	Referencia	P.V.R. KIT (1*) con campana	P.V.R. KIT (2*) posterior
P-221	60, 70, 90	INOX	V.730	FCA	1202647	70 €	130 €
P-227	60	INOX	V.850	FCA	1200041	160 €	215 €
P-227	60	INOX	V.850	FCRL-AE	1202614	215 €	270 €
P-227	70	INOX	V.850	FCA	1200016	160 €	215 €
P-227	70	INOX	V.850	FCRL-AE	1202615	215 €	270 €
P-227	90	INOX	V.850	FCA	1200067	160 €	215 €
P-227	90	INOX	V.850	FCRL-AE	1202616	215 €	270 €
P-401	70	INOX	V.750, V.850, V.1050, V.1250	FCRL-AE	1202569	215 €	270 €
P-401	80	INOX	V.750, V.850, V.1050, V.1250	FCRL-AE	1200062	215 €	270 €
P-401	90	INOX	V.750, V.850, V.1050, V.1250, V.1550, V.2350, V.2450	FCRL-AE	1200035	215 €	270 €
P-401	120	INOX	V.850, V.1050, V.1250, V.1550, V.2350, V.2450	FCRL-AE	1200102	215 €	270 €
P-417	90	INOX	V.750, V.850, V.1050, V.1250	FCRL-AE	1202563	215 €	270 €
P-725	90	BLA. / NEG.	V.850	FCA	1202646	55 €	85 €
P-730	90	BLA. / NEG.	V.850, V.1050	FCRL-AE	1200574	105 €	165 €
P-730	90	BLANCO	V.850, V.1050	FCA	1202514	160 €	215 €
P-732	60	BLA. / NEG.	V.750	FCA	1200189	160 €	215 €
P-732	60	BLA. / NEG.	V.750, V.850	FCRL-AE	1200573	215 €	270 €
P-732	90	BLA. / NEG.	V.850	FCA	1200190	160 €	215 €
P-732	90	BLA. / NEG.	V.750	FCA	1200194	160 €	215 €
P-732	90	BLA. / NEG.	V.750, V.850, V.1050	FCRL-AE	1200572	215 €	270 €
P-732	60, 70	BLA. / NEG.	V.850	FCA	1202514	160 €	215 €
P-745	90	INOX	V.850, V.1050	FCRL-AE	1200219	215 €	270 €
P-746	90	INOX	V.850, V.1050	FCRL-AE	1200231	215 €	270 €
P-746	120	INOX	V.850, V.1050	FCRL-AE	1200250	230 €	290 €
P-823N	60, 70, 90	INOX	V.850	FCA	1200230	55 €	105 €
P-825	60	INOX	V.750, V.850, V.1050	FCA	1200232	160 €	215 €
P-825	60	INOX	V.750, V.850, V.1050	FCRL-AE	1200233	215 €	270 €
P-825	60	BLANCO	V.750, V.850, V.1050	FCA	1200234	160 €	215 €
P-825	60	BLANCO	V.750, V.850, V.1050	FCRL-AE	1200235	215 €	270 €

## Kits de recirculación por modelo / Recirculation kits by model

### Campanas de Pared / Wall cooker hoods

Modelo	Frontal (cm)	Color	Versión motor	Kit sistema	Referencia	P.V.R. KIT (1*) con campana	P.V.R. KIT (2*) posterior
P-825	60	NEGRO	V.750, V.850, V.1050	FCA	1200236	160 €	215 €
P-825	60	NEGRO	V.750, V.850, V.1050	FCRL-AE	1200237	215 €	270 €
P-825	70	INOX	V.750, V.850, V.1050	FCA	1200103	160 €	215 €
P-825	70	BLANCO	V.750, V.850, V.1050	FCA	1200592	160 €	215 €
P-825	70	BLANCO	V.750, V.850, V.1050	FCRL-AE	1200593	215 €	270 €
P-825	70	INOX	V.750, V.850, V.1050	FCRL-AE	1202618	215 €	270 €
P-825	70	NEG	V.750, V.850, V.1050	FCA	1202648	160 €	215 €
P-825	70	NEG	V.750, V.850, V.1050	FCRL-AE	1202650	215 €	270 €
P-825	90	INOX	V.750, V.850, V.1050, V.1250	FCA	1200172	160 €	215 €
P-825	90	INOX	V.750, V.850, V.1050, V.1250	FCRL-AE	1202619	215 €	270 €
P-825	90	BLANCO	V.750, V.850, V.1050, V.1250	FCA	1202635	160 €	215 €
P-825	90	BLANCO	V.750, V.850, V.1050, V.1250	FCRL-AE	1202637	215 €	270 €
P-825	90	NEG	V.750, V.850, V.1050, V.1250	FCA	1202649	160 €	215 €
P-825	90	NEG	V.750, V.850, V.1050, V.1250	FCRL-AE	1202651	215 €	270 €
P-825	120	INOX	V.850, V.1050, V.1250	FCA	1200238	160 €	215 €
P-825	120	INOX	V.850, V.1050, V.1250	FCRL-AE	1200239	215 €	270 €
P-825	120	BLANCO	V.850, V.1050, V.1250	FCA	1200240	160 €	215 €
P-825	120	BLANCO	V.850, V.1050, V.1250	FCRL-AE	1200241	215 €	270 €
P-825	120	NEGRO	V.850, V.1050, V.1250	FCA	1200242	160 €	215 €
P-825	120	NEGRO	V.850, V.1050, V.1250	FCRL-AE	1200243	215 €	270 €
P-826	90	BLA. / NEG.	V.750, V.850	FCRL-AE	1202584	215 €	270 €
P-826	90	INOX	V.750, V.850	FCA	1202619	215 €	270 €
P-827	90	NEGRO	V.850	FCRL-AE	1202624	215 €	270 €
P-827	90	NEGRO	V.850	FCA	1202625	160 €	215 €
P-861	90	INOX	V.850, V.1050, V.1250, V.1550, V.2350, V.2450	FCRL-AE	1200216	185 €	540 €
P-861	105	INOX	V.850, V.1050, V.1250, V.1550, V.2350, V.2450	FCRL-AE	1202550	185 €	540 €
P-861	120	INOX	V.850, V.1050, V.1250, V.1550, V.2350, V.2450	FCRL-AE	1200217	225 €	585 €
P-861	140	INOX	V.1250, V.1550, V.2350, V.2450	FCRL-AE	1202592	225 €	585 €
P-861	150	INOX	V.1250, V.1550, V.2350, V.2450	FCRL-AE	1202581	275 €	635 €
P-861	180	INOX	V.1250, V.1550, V.2350, V.2450	FCRL-AE	1202589	275 €	635 €
P-861	90	NEGRO SATINADO	V.850, V.1050, V.1250, V.1550, V.2350, V.2450	FCRL-AE	1200244	185 €	540 €
P-861	105	NEGRO SATINADO	V.850, V.1050, V.1250, V.1550, V.2350, V.2450	FCRL-AE	1200245	185 €	540 €
P-861	120	NEGRO SATINADO	V.850, V.1050, V.1250, V.1550, V.2350, V.2450	FCRL-AE	1200246	225 €	585 €
P-861	140	NEGRO SATINADO	V.1250, V.1550, V.2350, V.2450	FCRL-AE	1200247	225 €	585 €
P-861	150	NEGRO SATINADO	V.1250, V.1550, V.2350, V.2450	FCRL-AE	1200248	275 €	635 €
P-861	180	NEGRO SATINADO	V.1250, V.1550, V.2350, V.2450	FCRL-AE	1200249	275 €	635 €
P-960	100	INOX, BL, NEG	V.1250	FCRL-AE	1202531	120 €	540 €
P-1001	90, 120	INOX -RAL	V.1050, V.1250, V.1550, V.2200, V.2350, V.2450	DIF. TECHO IX	9920	430 €	430 €
P-1001	90, 120	INOX -RAL	V.1050, V.1250, V.1550, V.2200, V.2350, V.2450	DIF. TECHO BL	9960	490 €	490 €
P-2000	100, 120, 150	INOX- VINTAGE -RAL	V.1050, V.1250, V.2200	DIF. TECHO IX	9920	430 €	430 €
P-2000	100, 120, 150	INOX- VINTAGE -RAL	V.1050, V.1250, V.2200	DIF. TECHO BL	9960	490 €	490 €
P-2010	90	INOX, CO, ORO, NEG	V.850, V.1050, V.1250	FCRL-AE	1200220	215 €	270 €
P-2010	90	CO	V.850, V.1050, V.1250	FCRL-AE	1200580	215 €	270 €
P-2010	90	ORO	V.850, V.1050, V.1250	FCRL-AE	1200582	215 €	270 €
P-2010	90	NEGRO MATE	V.850, V.1050, V.1250	FCRL-AE	1200584	215 €	270 €
P-2010	90	NEGRO TEXTURADO	V.850, V.1050, V.1250	FCRL-AE	1200586	215 €	270 €
P-2010	90	NEGRO SATINADO	V.850, V.1050, V.1250	FCRL-AE	1200588	215 €	270 €
P-2010	90	BLANCO	V.850, V.1050, V.1250	FCRL-AE	1200590	215 €	270 €
P-2010	120	INOX, CO, ORO, NEG	V.850, V.1050, V.1250	FCRL-AE	1200221	215 €	270 €
P-2010	120	CO	V.850, V.1050, V.1250	FCRL-AE	1200581	215 €	270 €
P-2010	120	ORO	V.850, V.1050, V.1250	FCRL-AE	1200583	215 €	270 €
P-2010	120	NEGRO MATE	V.850, V.1050, V.1250	FCRL-AE	1200585	215 €	270 €
P-2010	120	NEGRO TEXTURADO	V.850, V.1050, V.1250	FCRL-AE	1200587	215 €	270 €
P-2010	120	NEGRO SATINADO	V.850, V.1050, V.1250	FCRL-AE	1200589	215 €	270 €
P-2010	120	BLANCO	V.850, V.1050, V.1250	FCRL-AE	1200591	215 €	270 €

**F.C.A.:** Filtros de carbón activado estándar / *Standard filters activated carbon*  
**FCLR-AE:** Filtro de Carbón Activado Lavables y Reactivables de ALTA EFICIENCIA  
*HIGH-EFFICIENCY washable reactivatable carbon filters*

(1)\*: Precio KIT Suministrado con la campana

(2)\*: Precio KIT Suministrado posteriormente a la entrega de la campana

(1)\*: RSP kit ordered together with hood

(2)\*: RSP kit ordered individually

## Kits de recirculación por modelo / Recirculation kits by model Campanas de Isla / Island cooker hoods

Modelo	Frontal (cm)	Color	Versión motor	Kit sistema	Referencia	P.V.R. KIT (1*) con campana	P.V.R. KIT (2*) posterior
I-402	90, 120	INOX -RAL	V.1250, V.1550, V.2350	DIF. TECHO IX	9920	430 €	430 €
I-402	90, 120	INOX -RAL	V.1250, V.1550, V.2350	DIF. TECHO BL	9960	490 €	490 €
I-825	90	INOX	V.850, V.1250	FCA	1200141	105 €	430 €
I-825	90	INOX	V.850, V.1250	FCRL-AE	1200222	200 €	640 €
I-825	90	NEG.	V.850, V.1250	FCA	1202652	105 €	430 €
I-825	90	NEG.	V.850, V.1250	FCRL-AE	1202653	200 €	640 €
I-825	120	INOX	V.1250	FCRL-AE	1200223	200 €	640 €
I-825	120	INOX	V.1250	FCA	1202534	105 €	430 €
I-825	120	NEG.	V.1250	FCA	1202654	105 €	430 €
I-825	120	NEG.	V.1250	FCRL-AE	1202655	200 €	640 €
I-826	90	INOX	V.850, V.1250	FCA	1200141	105 €	430 €
I-826	90	INOX	V.850, V.1250	FCRL-AE	1200222	200 €	640 €
I-861	90	INOX	V.1250, V.1550, V.2350, V.2450	FCRL-AE	1200214	185 €	760 €
I-861	90	NEGRO	V.1250, V.1550, V.2350, V.2450	FCRL-AE	1200579	185 €	760 €
I-861	120	NEGRO	V.1250, V.1550, V.2350, V.2450	FCRL-AE	1200578	265 €	845 €
I-861	120	INOX	V.1250, V.1550, V.2350, V.2450	FCRL-AE	1202536	265 €	845 €
I-960	100	INOX, CRISTAL	V.1250, V.1550	FCRL-AE	1202509	116 €	539 €
I-1001	120, 140	INOX -RAL	V.1250, V.1550, V.2200, V.2350, V.2450	DIF. TECHO IX	9920	429 €	429 €
I-1001	120, 140	INOX -RAL	V.1250, V.1550, V.2200, V.2350, V.2450	DIF. TECHO BL	9960	490 €	490 €

## Kits de recirculación por modelo / Recirculation kits by model Campanas de Techo / Ceiling cooker hoods

Modelo	Frontal (cm)	Color	Versión motor	Kit sistema	Referencia	P.V.R. KIT (1*) con campana	P.V.R. KIT (2*) posterior
E-201	65	BLANCO	V.1130, V.1300, V.1550	FCRL-AE	1200577	215 €	270 €
E-217	110	BLANCO	V.1130	FCRL-AE	1202570	215 €	270 €
E-219	90	BLANCO	V.1130, V.1200	FCRL-AE	1200576	215 €	270 €
E-221	120	INOX, BLANCO	V.1130	FCA	1202538	160 €	215 €
E-221	120	INOX, BLANCO	V.1130	FCRL-AE	1202607	215 €	270 €
E-231	130	BLANCO	V.1130, V.1550, V.2350, V.2450	FCRL-AE	1202598	396 €	435 €
E-231	130	BLANCO	V.1130	FCRL-AE	1202633	396 €	435 €
E-232	130	BLANCO	V.1250	FCRL-AE	1202598	396 €	435 €
E-237	130	BLANCO	V.1130, V.1550, V.2350, V.2450	DIF. TECHO IX	9920	429 €	429 €
E-237	130	BLANCO	V.1130, V.1550, V.2350, V.2450	DIF. TECHO BL	9960	490 €	490 €
E-245	100	BLANCO	V.1130	FCRL-AE	1202645	215 €	270 €
E-250	130	INOX, BLANCO, NEGRO	V.1130, V.1550, V.2350, V.2450	FCRL-AE	1202526	215 €	270 €
E-250	160	INOX, BLANCO, NEGRO	V.2350, V.2450	FCRL-AE	1202604	215 €	270 €
E-250	190	INOX, BLANCO, NEGRO	V.2350, V.2450	FCRL-AE	1202527	314 €	369 €
E-252	95, 120	BLANCO	V.1130, V.1550, V.2350, V.2450	FCRL-AE	1202570	215 €	270 €
E-265	130	INOX, BLANCO, NEGRO	V.1130, V.1550, V.2350, V.2450	FCRL-AE	1202526	215 €	270 €
E-265	160	INOX, BLANCO, NEGRO	V.2350, V.2450	FCRL-AE	1202604	215 €	270 €
E-265	190	INOX, BLANCO, NEGRO	V.2350, V.2450	FCRL-AE	1202527	314 €	369 €
E-295	90	INOX	V.850, V.1350	FCRL-AE	1202559	160 €	215 €
E-297	95, 120	BLANCO	V.1130, V.1550, V.2350, V.2450	FCRL-AE	1202570	215 €	270 €
SKYRING	54	BLA. / NEG. / CO. / ORO / PLATA	V.1130, V.1550	FCRL-AE	1200226	160 €	215 €

**F.C.A.:** Filtros de carbón activado estándar / *Standard filters activated carbon*  
**FCRL-AE:** Filtro de Carbón Activado Lavables y Reactivables de ALTA EFICIENCIA  
*HIGH-EFFICIENCY washable reactivatable carbon filters*

(1)\*: Precio KIT Suministrado con la campana

(2)\*: Precio KIT Suministrado posteriormente a la entrega de la campana

(1)\*: RSP kit ordered together with hood

(2)\*: RSP kit ordered individually

## Kits de recirculación por modelo / Recirculation kits by model

### Campanas de Integración / Integrated cooker hoods

Modelo	Frontal (cm)	Color	Versión motor	Kit sistema	Referencia	P.V.R. KIT (1*) con campana	P.V.R. KIT (2*) posterior
E-320	90	INOX, NEGRO	V.950, V.1200	FCA	1200055	105 €	140 €
E-320	90	INOX.	V.950, V.1200	FCRL-AE	1202673	195 €	230 €
E-320	120	INOX, NEGRO	V.950, V.2000	FCA	1200205	105 €	140 €
E-320	120	INOX.	V.950, V.2000	FCRL-AE	1202674	195 €	230 €
E-350	90	INOX, NEGRO	V.1350	FCRL-AE	1200218	195 €	230 €
E-350	120	INOX	V.1350	FCRL-AE	1200575	195 €	230 €
BGF SEC	50	INOX	V.750, V.850, V.1050	FCRL-AE	1200204	175 €	215 €
BGF SEC	75	INOX	V.750, V.850, V.1050, V.1250, V.1550	FCRL-AE	1202519	175 €	215 €
BGF SEC	99	INOX	V.750, V.850, V.1050, V.1250, V.1550, V.2350, V.2450	FCRL-AE	1200187	175 €	215 €
BGF SEC	124	INOX	V.850, V.1250, V.1550, V.2350, V.2450	FCRL-AE	1202554	175 €	215 €
ES	60, 70, 90	INOX	V.730	FCA	1202605	85 €	140 €
EVO	58	INOX	V.750, V.850, V.1050	FCRL-AE	1200165	175 €	215 €
EVO	78	INOX	V.750, V.850, V.1050, V.1250, V.1550	FCRL-AE	1200171	175 €	215 €
EVO	94,8	INOX	V.750, V.850, V.1050, V.1250	FCRL-AE	1202513	175 €	215 €
EVO	111	INOX	V.850, V.1050, V.1250, V.1550	FCRL-AE	1200179	175 €	215 €
EVO	128,5	INOX	V.850, V.1050, V.1250, V.1550	FCRL-AE	1202532	175 €	215 €
GIM-2	60, 90, 120	INOX	V.850	FCA	1202582	160 €	215 €
GIM-3	90	INOX	V.850	FCA	1202582	160 €	215 €
GIT	60	INOX, BLANCO, NEGRO	V.850	FCA	1200215	85 €	140 €
GR05	60, 90	INOX	V.700	FCA	1200097	85 €	125 €
GR05	60, 90	INOX	V.730	FCR	1202605	85 €	125 €
GR20	60	INOX.	V.700	FCA	1202644	85 €	125 €
GRV	52	INOX CR GRIS	V.850	FCRL-AE	1200224	175 €	215 €
GRV	78	INOX CR GRIS	V.850	FCRL-AE	1200225	175 €	215 €
GTI	51	INOX, NEG.	V.750, V.1050	FCRL-AE	1202657	135 €	360 €
GTI	72,5	INOX, NEG.	V.750, V.850, V.1050, V.1250, V.1550	FCRL-AE	1202658	175 €	430 €
GTI	81	INOX, NEG.	V.850, V.1050, V.1250, V.1550	FCRL-AE	1202659	175 €	430 €
GTI	111	INOX, NEG.	V.850, V.1050, V.1250	FCRL-AE	1202660	220 €	500 €
GTI	128	INOX, NEG.	V.850, V.1250	FCRL-AE	1202661	265 €	575 €
IES	60, 90	INOX, BLANCO, NEGRO	V.850	FCA	1200215	85 €	140 €
NCR	52	INOX	V.850	FCA	1202590	85 €	140 €
NCR	52	INOX	V.850	FCRL-AE	1202611	175 €	215 €
NCR	78	INOX	V.850	FCA	1202591	85 €	140 €
NCR	78	INOX	V.850	FCRL-AE	1202612	175 €	215 €
NCR	111	INOX	V.850	F.C.L.R.-AE	1202539	175 €	215 €
NEO	52	INOX	V.850	FCA	1200568	85 €	140 €
NEO	52	INOX	V.850	FCRL-AE	1202609	175 €	215 €
NEO	78	INOX	V.850	FCA	1200569	85 €	140 €
NEO	78	INOX	V.850	FCRL-AE	1202610	175 €	215 €
PGF	60, 70	INOX	V.730	FCA	1202605	85 €	140 €
PRO	52	INOX	V.850, V.1050	FCRL-AE	1202566	175 €	215 €
PRO	85	INOX	V.850, V.1050, V.1250	FCRL-AE	1202567	175 €	215 €
PRO	100	INOX	V.850, V.1050, V.1250	FCRL-AE	1202577	175 €	215 €
TIB	60, 90	INOX	V.730	FCA	1202605	85 €	140 €
TIM	60	INOX	V.750, V.850	FCRL-AE	1202595	175 €	215 €
TIM	90	INOX	V.750, V.850	FCRL-AE	1202596	175 €	215 €
TIM	120	INOX	V.850	FCRL-AE	1202597	175 €	215 €
TIM-2	60	INOX	V.750, V.850	FCRL-AE	1202595	175 €	215 €
TIM-2	60	INOX	V.750, V.850	FCRL-AE	1202667	175 €	215 €
TIM-2	120	INOX.	V.850	FCRL-AE	1202669	175 €	215 €
TIM-2	80, 90	INOX	V.750, V.850	FCRL-AE	1202668	175 €	215 €
TIX	60	INOX CR BL-NE	V.750, V.850, V.1050	FCRL-AE	1200227	175 €	215 €
TIX	90	INOX CR BL-NE	V.750, V.850, V.1050, V.1250	FCRL-AE	1200228	175 €	215 €
TIX	120	INOX	V.850, V.1050, V.1250	FCRL-AE	1200229	175 €	215 €

**F.C.A.:** Filtros de carbón activado estándar / *Standard filters activated carbon*  
**FCLR-AE:** Filtro de Carbón Activado Lavables y Reactivables de ALTA EFICIENCIA  
*HIGH-EFFICIENCY washable reactivatable carbon filters*

(1)\*: Precio KIT Suministrado con la campana

(2)\*: Precio KIT Suministrado posteriormente a la entrega de la campana

(1)\*: RSP kit ordered together with hood

(2)\*: RSP kit ordered individually



# Base Inox para GRUPO Filtrantes

## Stainless Steel base for filtering SETS



Este producto solo se suministra bajo pedido conjunto con el grupo filtrante correspondiente. Esta base inox se fabrica para cualquiera de nuestros grupos filtrantes a medida, bajo presupuesto.

**Cualquier variación sobre las medidas indicadas, bajo presupuesto.**

This stainless steel base is only supplied on request together with the corresponding filter group. This stainless steel base is manufactured for any of our filtering sets custom-made, on request

**Any variation to the above sizes, on request.**

### Base INOX EVO

#### Stainless Steel base for EVO

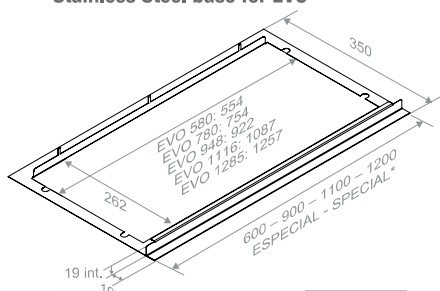

Base	Ref.	P.V.R.
Base INOX EVO 580	009136	80 €
Base INOX EVO 780	009137	95 €
Base INOX EVO 948	009985	125 €
Base INOX EVO 1116	009986	135 €
Base INOX EVO 1285	009989	140 €

### Base INOX NEO/NCR

#### Stainless Steel base for NEO/NCR

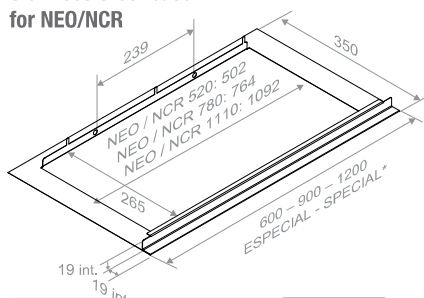

Base	Ref.	P.V.R.
Base INOX NEO / NCR 520	009138	80 €
Base INOX NEO / NCR 780	009139	95 €
Base INOX NCR 1110	010080	135 €

### Base GTI

#### Base for GTI

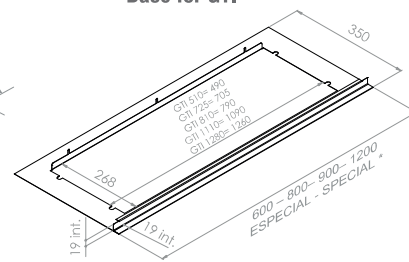

Base	Ref.	P.V.R.
INOX/S.S. GTI 510	010203	88 €
INOX/S.S. GTI 725	010204	105 €
INOX/S.S. GTI 810	010205	116 €
INOX/S.S. GTI 1110	010206	149 €
INOX/S.S. GTI 1280	010207	154 €

### Base INOX GRV

#### Stainless Steel base for GRV

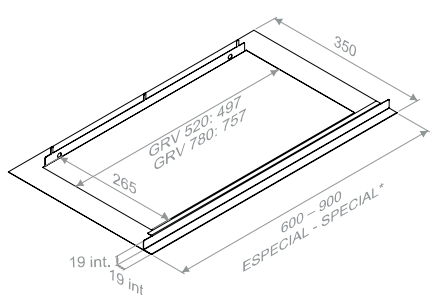

Base	Ref.	P.V.R.
Base INOX GRV 520	010118	80 €
Base INOX GRV 780	010119	95 €

### Base INOX PRO

#### Stainless Steel base for PRO

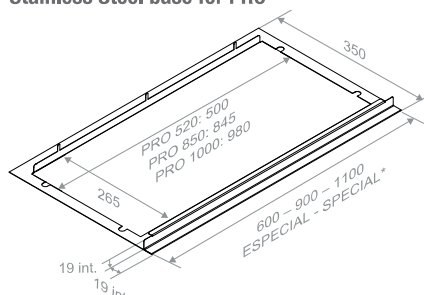

Base	Ref.	P.V.R.
Base INOX PRO 520	009823	80 €
Base INOX PRO 850	009824	95 €
Base INOX PRO 1000	009987	135 €

Base	Ref.	P.V.R.
NEGRA/BLACK GTI 510	010226	100 €
NEGRA/BLACK GTI 725	010227	120 €
NEGRA/BLACK GTI 810	010228	130 €
NEGRA/BLACK GTI 1110	010229	165 €
NEGRA/BLACK GTI 1280	010230	175 €

Notas / Notes

\*MEDIDA ESPECIAL bajo presupuesto  
\*SPECIAL SIZE under request

# Difusor de techo

## Ceiling diffuser

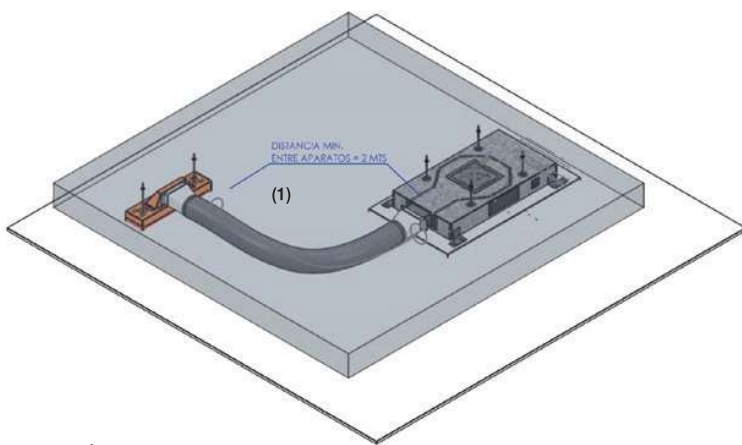

Para la instalación, crear en el falso techo un espacio de 665 mm x 165 mm con una altura mínima de 210 mm.  
**(1) Distancia mínima entre campana y difusor de 2 m.**

For installation cut out an area of 665 mm x 165 mm at a minimum height of 210 mm in the false ceiling.  
**(1) Minimum distance between hood and diffuser of 2 m.**

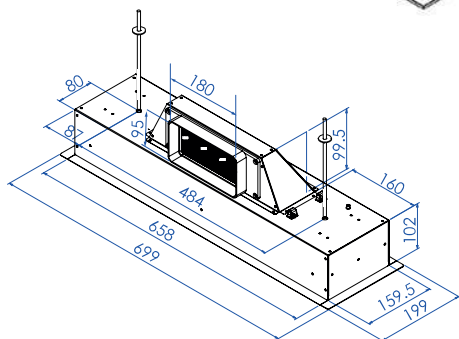

Descripción / Description	Medidas Encastre Built in Sizes	Ref.	P.V.R.
Difusor de techo INOX SIN filtro cerámico Ceiling diffuser Stainless Steel WITHOUT ceramic carbon filter	165 x 665 mm	009919	195 €
Difusor de techo INOX CON filtro cerámico Ceiling diffuser Stainless Steel WITH ceramic carbon filter	165 x 665 mm	009920	390 €
Difusor de techo BLANCO SIN filtro cerámico Ceiling diffuser WHITE WITHOUT ceramic carbon filter	165 x 665 mm	009959	280 €
Difusor de techo BLANCO CON filtro cerámico Ceiling diffuser WHITE WITH ceramic carbon filter	165 x 665 mm	009960	445 €

### FILTRO CERAMICO REACTIVABLE DE ALTA EFICIENCIA + DIFUSOR

Gracias a las excelentes prestaciones de estos filtros CERAMICOS DE ALTA EFICIENCIA de última generación (FCCR), son posibles diferentes opciones de instalación de manera que cualquier modelo de campana puede equiparse con ellos; esto se consigue usando un DIFUSOR DE TECHO o un DIFUSOR DE ZÓCALO. Estos accesorios le permiten obtener una calidad Premium en la circulación del aire.

### HIGH-EFFICIENCY reactivatable CERAMIC active carbon filter + DIFFUSER

Thanks to the excellent performance of these new latest-generation HIGH-EFFICIENCY CERAMIC filters (FCCR), different fitting options are available so that all hood models can be equipped with them. This is done using a CEILING DIFFUSER or a SPECIAL PLINTH DIFFUSER. These fittings enable you to benefit from a totally premium recirculation quality.



# DIFUSOR rejilla zócalo

## Plinth diffuser

### Difusor zócalo H 60 mm

### Plinth diffuser H 60 mm

**SALIDA FRONTAL**  
FRONT EXIT

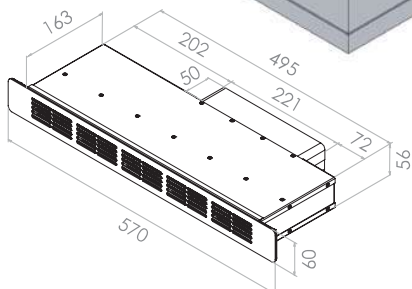
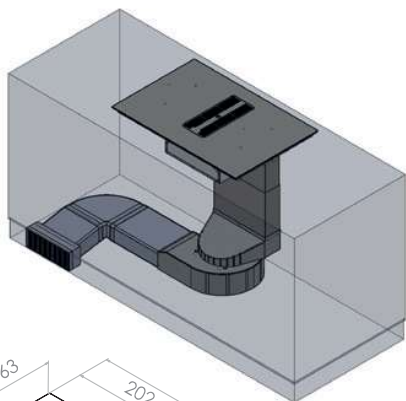

**SALIDA LATERAL**  
SIDE EXIT

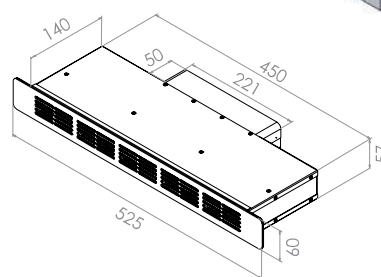
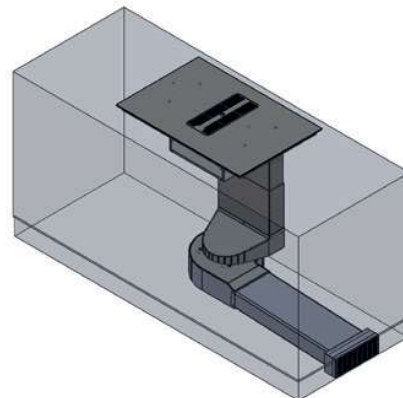

Descripción / Description	Ref.	P.V.R.
Difusor ALUMINIO a zócalo con filtro cerámico H.60 mm (570 mm) - Salida frontal Plinth diffuser ALUMINIUM with ceramic carbon filters. H 60 mm (570 mm) - Front exit	010042	255 €
Difusor BLANCO a zócalo con filtro cerámico H.60 mm (570 mm) - Salida frontal Plinth diffuser WHITE with ceramic carbon filters. H 60 mm (570 mm) - Front exit	010043	285 €
Difusor ALUMINIO a zócalo con filtro cerámico H.60 mm (525 mm) - Salida lateral Plinth diffuser ALUMINIUM with ceramic carbon filters. H 60 mm (525 mm) - Side exit	010197	285 €
Difusor BLANCO a zócalo con filtro cerámico H.60 mm (525 mm) - Salida lateral Plinth diffuser WHITE with ceramic carbon filters. H 60 mm (525 mm) - Side exit	010198	315 €

### Difusor zócalo H 108 mm

### Plinth diffuser H 108 mm

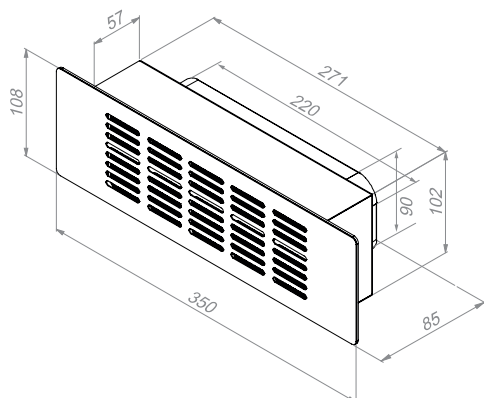

Descripción / Description	Ref.	P.V.R.
Difusor ALUMINIO a zócalo con filtro cerámico H.108 mm Plinth diffuser ALUMINIUM with ceramic carbon filters. H.108 mm	009984	270 €
Difusor BLANCO a zócalo con filtro cerámico H.108 mm Plinth diffuser WHITE with ceramic carbon filters. H.108 mm	010037	305 €

# Tubos extracción de humos

## Smoke extraction ductings

### ■ Unidad mínima de venta 5 m.

**CARACTERÍSTICAS:** Tubo flexible fabricado por múltiples capas de aluminio y poliéster que envuelven y recubren un centro de acero en forma de espiral muy resistente. Este tubo no genera ningún tipo de gas tóxico en caso de incendio. Temperatura de trabajo -30° C a + 150° C. Presión de trabajo hasta 3000 Pa.

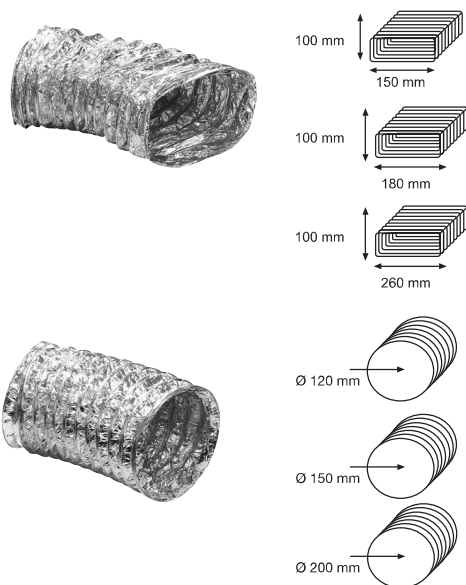

### ■ Minimum unit of sale 5 m

**FEATURES:** Flexible ducting made by multiple layers of aluminium and polyester lining that envelop and coat a steel core in a very resistant spiral shape. This type of flexible ducting does not generate any kind of toxic gas in the event of a fire. Working Temperature -30° C to + 150 °C. Working pressure up to 3000 Pa.

	5 m	10 m
Descripción / Description	Ref.	Ref.
Tubo rectangular equivalente a Ø120 Ø120 rectangular spiral pipe	009802 P.V.R. 95 €	006743 P.V.R. 175 €
Tubo rectangular equivalente a Ø150 Ø150 rectangular spiral pipe	009182 P.V.R. 115 €	006745 P.V.R. 199 €
Tubo rectangular equivalente a Ø200 Ø200 rectangular spiral pipe	009803 P.V.R. 125 €	006747 P.V.R. 235 €
Tubo circular de a Ø120 120 circular spiral pipe	009804 P.V.R. 95 €	006742 P.V.R. 175 €
Tubo circular de a Ø150 150 circular spiral pipe	007234 P.V.R. 115 €	006744 P.V.R. 199 €
Tubo circular de a Ø200 200 circular spiral pipe	009805 P.V.R. 125 €	006746 P.V.R. 235 €

# Tubos extracción de humos S.E.C. System®

## Smoke extraction ductings S.E.C. System®

**CARACTERÍSTICAS:** Conductos flexibles aislados de aluminio y poliéster. Constan de un conducto interior perforado con doble cámara, relleno por un compuesto de 25 mm de material aislante y envuelto con aluminio flexible fono-absorbente y micro-poro, todo ello recubierto con malla de fibra. Los conductos S.E.C. System® ofrecen un buen aislamiento tanto térmico como acústico. Radio de curvatura mínimo: 0,6 x Ø. Temperatura de trabajo -30° C a + 150° C.

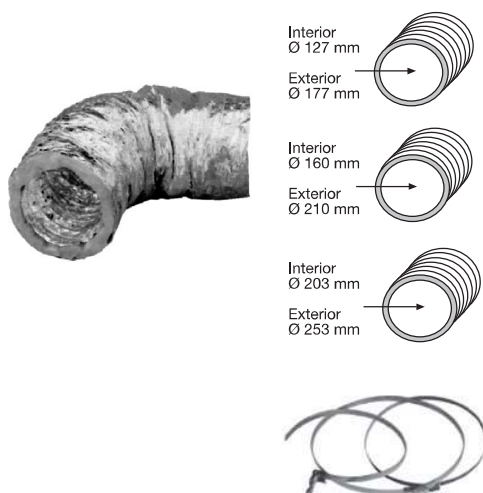

**FEATURES:** Flexible ducting soundproof made of aluminium and polyester. Consists of a perforated inner duct with dual chamber, filled with a composite with 25 mm of insulating material and wrapped with phono-absorbent and micro-pore flexible aluminium, all of which is covered with mesh fibre. The S.E.C. System® ducts offer a good level of heat and acoustic isolation. Minimum bend radius: 0.6 x Ø. Working Temperature -30° C to + 150 °C.

	5 m	10 m
Descripción / Description	Ref.	Ref.
Tubo insonorizado V.1. Ø127 V.1.Ø127 soundproof pipe	009806 P.V.R. 130 €	007814 P.V.R. 235 €
Tubo insonorizado V.1. Ø160 V.1.Ø160 soundproof pipe	009807 P.V.R. 145 €	007815 P.V.R. 260 €
Tubo insonorizado V.1. Ø203 V.1.Ø203 soundproof pipe	009084 P.V.R. 170 €	007816 P.V.R. 310 €
Descripción / Description	Ref.	
Brida sujeción tubo SEC System Ø125 Ducting fastening flange SEC System Ø125	009314 P.V.R. 1 €	
Brida sujeción tubo SEC System Ø150 Ducting fastening flange SEC System Ø150	009315 P.V.R. 1 €	



# Accesorios para instalación de campanas

## Accessories for proper cooker hoods installation

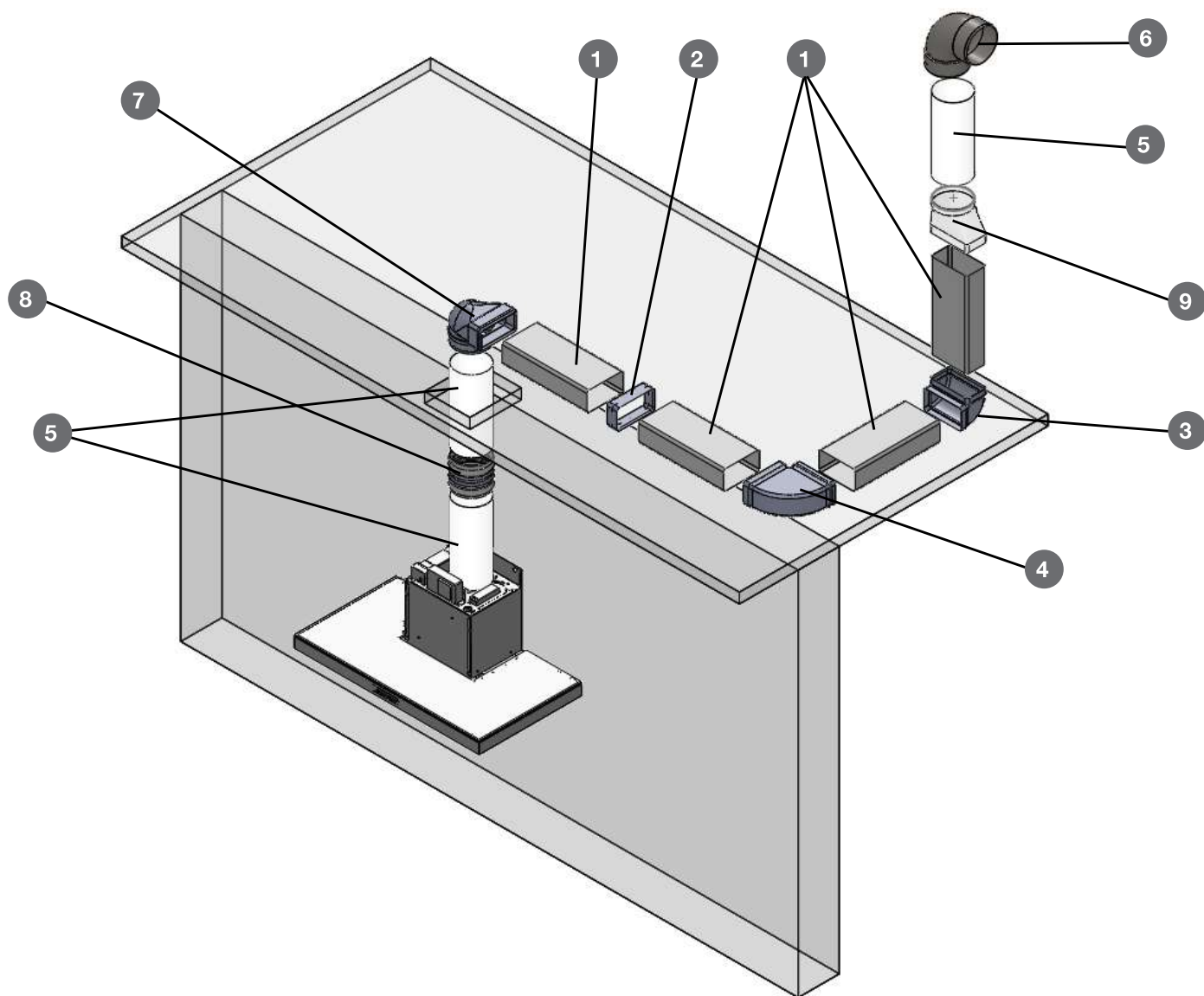

# Accesorios para instalación de campanas

## Accessories for proper cooker hoods installation

### Rectangular / Rectangular 180x90

**1**

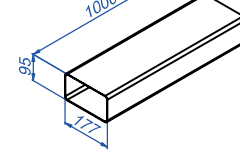
Tubo rectangular  
Rectangular duct  
180 x 90 mm L= 1000 mm

Ref.	P.V.R.
009809	40 €

Conducto rectangular  
Rectangular duct  
180 x 90 mm L= 280 mm

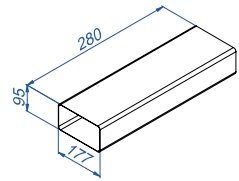
Ref.	P.V.R.
640064500088	20 €

**2**

Empalme rectangular  
Straight connector  
180 x 90 mm

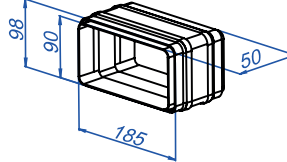
Ref.	P.V.R.
010437	12 €

**3**

Codo rectangular vertical 90° \*  
Vertical bend 90°  
180 x 90 mm

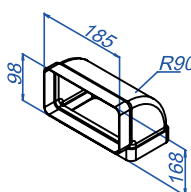
Ref.	P.V.R.
010438	20 €

**4**

Codo rectangular horizontal 90° \*  
Straight bend 90°  
180 x 90 mm

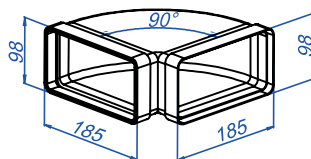
Ref.	P.V.R.
010439	25 €

**7**

Codo vertical redondo a rectangular. Curva 180x90 mm  
Mixed 180x90mm  
Ø150 mm

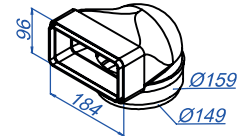
Ref.	P.V.R.
010440	35 €

**9**

Convertidor Ø150  
Connector  
90x180

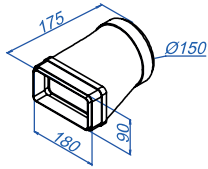
Ref.	P.V.R.
009310	30 €

Soporte  
90x220 (marco)  
90x180 (salida)

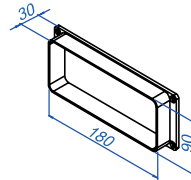
Ref.	P.V.R.
640064500070	18 €

Adaptador  
220x55 / 180x90

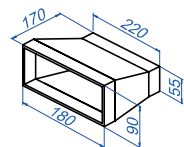
Ref.	P.V.R.
010104	30 €

# Accesorios para instalación de campanas

## Accessories for proper cooker hoods installation

### Rectangular / Rectangular 220x90

**1**

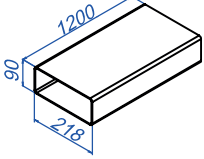
Tubo rectangular  
Rectangular duct  
220 x 90 mm L= 1200 mm

Ref.	P.V.R.
009813	45 €

**2**

Empalme rectangular  
Straight connector  
220 x 90 mm

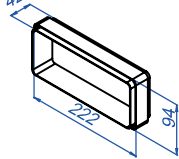
Ref.	P.V.R.
009814	17 €

**3**

Codo rectangular vertical 90°  
Vertical bend 90°  
220 x 90 mm

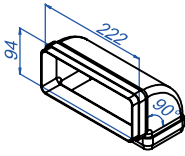
Ref.	P.V.R.
009815	25 €

**4**

Codo rectangular horizontal 90°  
Straight bend 90°  
220 x 90 mm

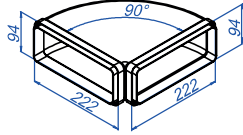
Ref.	P.V.R.
010441	30 €

Soporte  
90x220  
Marco salida

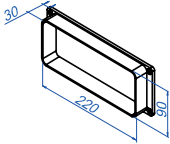
Ref.	P.V.R.
640064500081	18 €

**9**

Convertidor recto Ø150 mm / 200x90 mm  
Mixed straight connector

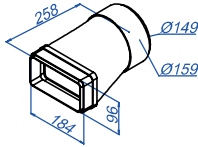
Ref.	P.V.R.
009905	54 €

**7**

Codo redondo a rectangular  
Ø150 90x220 90°  
convertidor

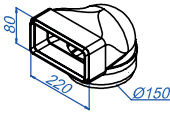
Ref.	P.V.R.
640064500079	45 €

Adaptador  
220x55 / 220x90

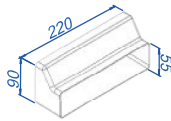
Ref.	P.V.R.
640064500121	40 €

### Rectangular / Rectangular 220x55

Tubo rectangular  
Rectangular duct  
220 x 55 mm L: 1000 mm

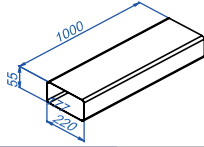
Ref.	P.V.R.
010100	45 €

Codo rectangular vertical 90°  
Vertical bend 90°  
220 x 55 mm

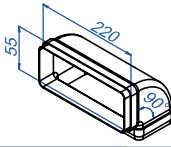
Ref.	P.V.R.
640064500111	40 €

Codo rectangular horizontal 90°  
Horizontal bend 90°  
220 x 55 mm

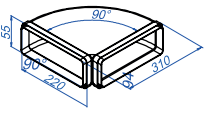
Ref.	P.V.R.
010101	45 €

Empalme rectangular  
Straight connector  
220 x 55 mm

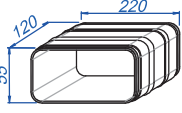
Ref.	P.V.R.
010442	40 €

# Accesorios para instalación de campanas

## Accessories for proper cooker hoods installation

### Rectangular / Rectangular 220x55 (cont.)



Codo vertical redondo a rectangular  
220x55 / Ø125 / 90°

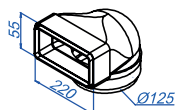

Ref.	P.V.R.
640064500116	55 €



Empalme  
220x55 / Ø125

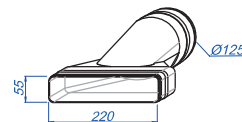

Ref.	P.V.R.
010102	50 €

### Circular / Circular Ø150

5



Tubo redondo  
Circular Duct  
Ø150 mm L= 1000 mm

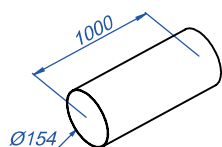

Ref.	P.V.R.
009817	35 €

8



Empalme redondo  
Ø150

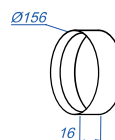

Ref.	P.V.R.
009601	20 €

6



Codo redondo  
Ø150

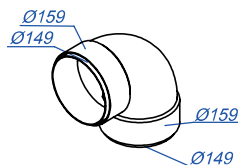

Ref.	P.V.R.
009308	35 €

### Varios



Convertidor  
80x230  
90x220

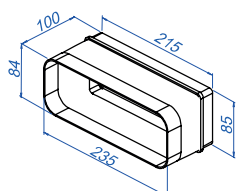

Ref.	P.V.R.
640064500080	45 €



Ajuste aro  
80x230  
salida

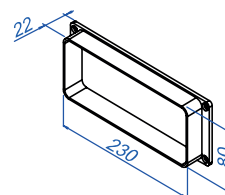

Ref.	P.V.R.
640064500033	55 €



Convertidor  
80x230  
Ø150

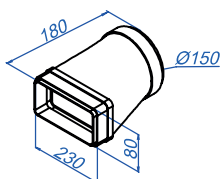

Ref.	P.V.R.
640064500053	60 €



# Válvulas anti-retorno, ventanillas y rejillas

## Backdraft shutters, windows and vents



### Válvulas de cierre anti-retorno Backdraft shutters

Características: Compuerta antiretorno metálica para instalar en la descarga de los ventiladores. Impiden la entrada de olores, corrientes de aire y evitan fugas de calefacción cuando el extractor no funciona.

Features: metal backdraft shutters to install at the exit delivery. Prevents from the entry of odours, air streams and heating leaks from the outside when the extractor is not on.

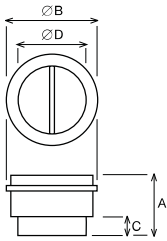

	A	Ø B	C	Ø D	Ref.	P.V.R.
Ø 125 mm	107	139	31,5	119,5	006723	90 €
Ø 150 mm	121	163,5	35	147	006724	100 €
Ø 160 mm	121	173,5	35	157	006725	100 €
Ø 200 mm	131,5	214	35	197,5	006726	110 €



### Ventanillas de apertura por sobrepresión Wall outlet with gravity flat

Características: Persiana de sobrepresión construida en material termoplástico, estabilizado contra los rayos UV. Resistencia a los flujos abrasivos.

Features: Overpressure blind manufactured in thermoplastic material, stabilized against UV rays. Resistance to abrasive flows.

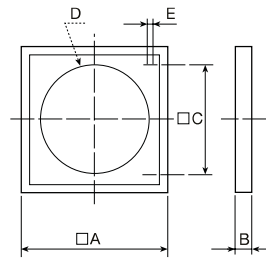

	Ø A	B	C	Ø D	Ø E	Ref.	P.V.R.
Ø 130 mm	158	15	110	130	4	006711	65 €
Ø 152 mm	178	20	130	152	4	006712	95 €
Ø 205 mm	243	21	184	205	5	006713	120 €



Rejillas exteriores INOX.  
Outdoor gills in S/Steel with backdraft shutter

	Ref.	P.V.R.
Ø 150 mm	008769	160 €
Ø 200 mm	008770	185 €

Características: Realizada en INOX, tiene una doble función: impide la entrada de corrientes de aire, y por otra parte, su rejilla exterior protege de la entrada de cuerpos extraños dentro del conducto.

Features: Made of stainless steel, with a dual function: prevents the entry of air streams, while its outside grill protects from the entry of foreign objects inside the duct.

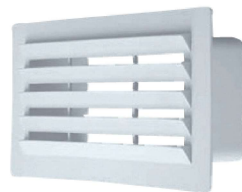
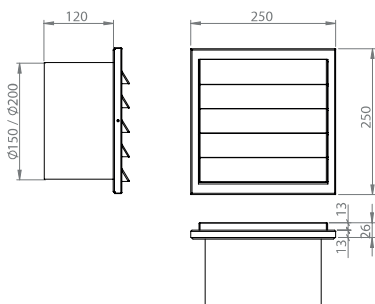

Rejilla final tubo rectangular PVC  
PVC ventilation grill for rectangular ducting

	Ref.	P.V.R.
180 x 90 mm	009850	25 €

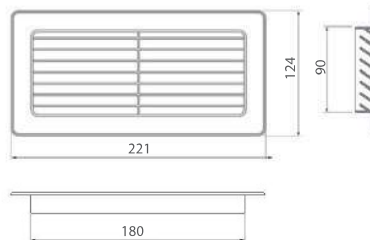

Rejilla final tubo rectangular PVC  
PVC ventilation grill for rectangular ducting

	Ref.	P.V.R.
220 x 90 mm	010417	36 €

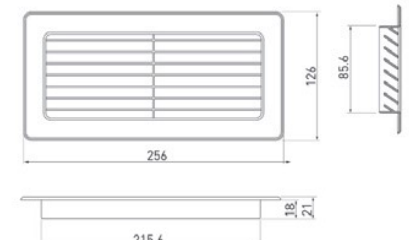

## Otros accesorios Other Accessories

### Tubo silenciador para conducto Silencer tube for pipe



Descripción / Description	mm				Ref.	P.V.R.
	Ø A	Ø B	C	D		
Ø 160 mm	160	250	600	700	009952	395 €
Ø 200 mm	200	300	600	700	009953	495 €

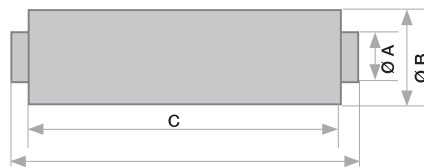

### Caja soporte insonorizada para motores de tejado Soundproof support box for roof motors

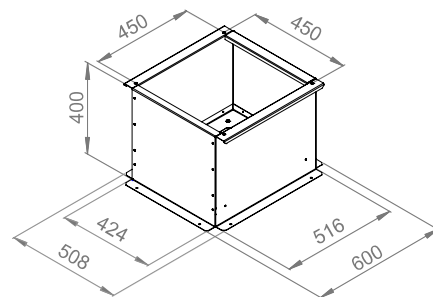

Ref.	P.V.R.
008624	265 €

Características: Fabricada en acero galvanizado, interior del plenum con sistema de insonorización S.E.C. System by Pando, ideal para reducir la pérdida de caudal y disminuir el nivel sonoro. Aconsejable para instalaciones de conducto que tengan un recorrido de campana a motor inferior a 4 m.

Features: Manufactured in galvanized steel, plenum interior has S.E.C. soundproof system by Pando, ideal to reduce the loss of flow and to reduce the noise level. Recommended for piping installations with a distance of less than 4 m from hood to motor.

### Tarifa de precios de campanas Inox esmaltadas epoxi Epoxy enamelled cooker hood price list

	COLOR PINTURA			
	Blanco RAL 9003 White	Negro RAL 9005 Black	Negro satinado Satin Black	Negro texturado Textured Black
CAMPANAS INOX PARED DECORATIVE COOKER HOODS WALL	295 €	295 €	325 €	350 €
CAMPANAS INOX ISLA DECORATIVE COOKER HOODS ISLAND	360 €	360 €	390 €	420 €
CAMPANAS INOX TECHO PEQUEÑAS DECORATIVE COOKER HOODS CEILING SMALL (E-290 y/and E-295)	295 €	295 €	325 €	350 €
CAMPANAS INOX TECHO DECORATIVE COOKER HOODS CEILING (RESTO MODELOS / ALL REMAINING MODELS)	360 €	360 €	390 €	420 €
CAMPANAS DE FORMATO ESPECIAL SPECIAL SIZE COOKER HOODS	Bajo presupuesto On request	Bajo presupuesto On request	Bajo presupuesto On request	Bajo presupuesto On request

## Advertencias / Notas Comments / Notes

- Pando se reserva el derecho de cambiar o anular cualquier medida de los artículos del catálogo, sin previo aviso y no se hace responsable de los errores u omisiones que pudieran darse en el catálogo o en esta tarifa. Características técnicas y precios de referencia válidos salvo error tipográfico u omisión.
- La configuración de la zona inferior de las campanas, en cuanto a filtros e iluminación puede variar según la imagen del catálogo, dependiendo el modelo y medida de la misma, con la finalidad de optimizar el rendimiento del producto en función de los elementos de cocción que tengan previsto instalar. Para ello nuestro departamento técnico está a su servicio para asesorarle.
- Debe tenerse en cuenta también, tanto en los motores exteriores como en los motores de tejado y mural, la necesidad de facilitar la accesibilidad al motor en caso de reparación o mantenimiento, ya sea en falsos techos dejando registro, en muros, en tejados o en chimeneas debe de preverse un acceso seguro para el personal técnico. Pando no podrá responsabilizarse de la reparación de este componente, si no se tiene en cuenta lo prescrito para estos motores.
- Pando reserves its right (without any prior notice) to change or cancel any size of catalogue items and is not responsible for errors or omissions arising thereby. Technical characteristics and reference prices are valid except for typographical errors and omissions.
- The configuration of the filters and lighting of the hood can vary from the catalogue illustration, depending on the model and size of the hood. This is to maximise the performance of the product and is dependent on the layout of the cooking elements. Our technical department will gladly offer you advice on how to do this.
- It is important to remember the requirement to ensure easy access to the motor in case of need for repair or maintenance, whether in false ceilings, walls, roofs or fireplaces, to ensure a secure access for the technical personnel of Pando. Pando shall not be responsible to repair these motors where the installation instructions of Pando were not followed.

## Notas finales Iberia Final notes Iberia

- Precios válidos hasta nuevo aviso. LOS PRECIOS NO INCLUYEN EL RESPECTIVO IMPUESTO.
- NO SE ADMITEN DEVOLUCIONES que no hayan sido autorizadas por Pando directamente y deberán ir acompañadas del número de albarán con el que fueron entregadas y con el número de factura correspondiente, si ya obra en su poder.
- VERIFIQUEN EL MATERIAL A SU ENTREGA. Sólo se dispone de 24h. para reclamar los posibles daños ocasionados por el transporte a la compañía aseguradora. Pando se reserva el derecho a verificar toda devolución y generar factura de cargo en caso de una deficiente manipulación del material.
- Los productos Pando disponen de garantía, siempre y cuando los mismos estén debidamente manipulados e instalados por personal especializado. Sólo se aceptará la devolución de material en su embalaje original.
- Portes de envío incluidos para Península Ibérica, Baleares y Canarias. Para ventas inferiores a 250€, los portes serán debidos. Los portes del envío se incluirán en la factura.
- En el caso de recambios, se cobrarán los portes en la factura.
- Prices are available until further notice. PRICES DON'T INCLUDE THE RESPECTIVE TAXES.
- RETURNS that have not been authorised directly by PANDO WILL NOT BE ACCEPTED and must be supported by the delivery note number with which they were delivered, and with the corresponding invoice number if it has already been received by the customer.
- CHECK THE MATERIAL AT THE TIME OF DELIVERY. You only have 24 hours to claim any damage caused by the transport to the insurance company. Pando reserves the right to check all returns and to generate a charge invoice in case of poor handling of the material.
- Pando products are guaranteed, provided that they have been properly handled and installed by specialised personnel. We will only accept the return of material in its original packaging.
- Shipping charges are included for the Iberian Peninsula, Balearic, and Canary Islands. For sales of less than 250€, shipping costs will be charged. Postage will be included in the invoice.
- In the case of replacement parts, postage will be charged to the invoice.
- Pando dispone de una amplia red de servicio Post Venta en todos los países donde distribuye sus productos que garantiza su calidad en el mantenimiento, servicio de repuestos y accesorios originales Pando. Para más información consulte nuestra web.
- También disponemos de una División Técnica en la Central de Pando, que atenderá sus consultas técnicas y solicitudes de servicio técnico, garantizando la mejor atención personalizada
- Pando has an extensive after-sales service network in all the countries where it distributes the products, which guarantees the quality of maintenance, service, original Pando spare parts, and accessories. For more information, please visit our website.
- We also have a Technical Division at Pando Headquarters, which will attend to your technical requests and questions, guaranteeing the best personalised attention.

### Datos de contacto Servicio Técnico Oficial Autorizado Pando / Official Pando Customer Service Contact Details

ESPAÑA, PORTUGAL Y ANDORRA:	OTROS PAÍSES:	
<p>ES <a href="http://www.pando.es/asistencia-tecnica/">www.pando.es/asistencia-tecnica/</a></p> 	<p>EN <a href="https://www.pando.es/en/after-sales-services/">https://www.pando.es/en/after-sales-services/</a></p> <p>FR <a href="https://www.pando.es/fr/service-apres-vente/">https://www.pando.es/fr/service-apres-vente/</a></p>	





# ***Pando***

Fabricado por INOXPAN, S.L.

Pol. Ind. El Cros  
Av. El Molí de les Mateves, 11  
Apdo. Correos nº 21  
08310 ARGENTONA  
(Barcelona - Spain)

Tel. +34 93 757 94 11  
Fax +34 93 757 96 53

**Nacional:** [com.pando@pando.es](mailto:com.pando@pando.es)

**Export:** [export@pando.es](mailto:export@pando.es)

**[www.pando.es](http://www.pando.es)**

